

W. DONALDSON.  
Lathe for Turning Pottery-Ware.

No. 197,616.

Patented Nov. 27, 1877.

Fig. 1

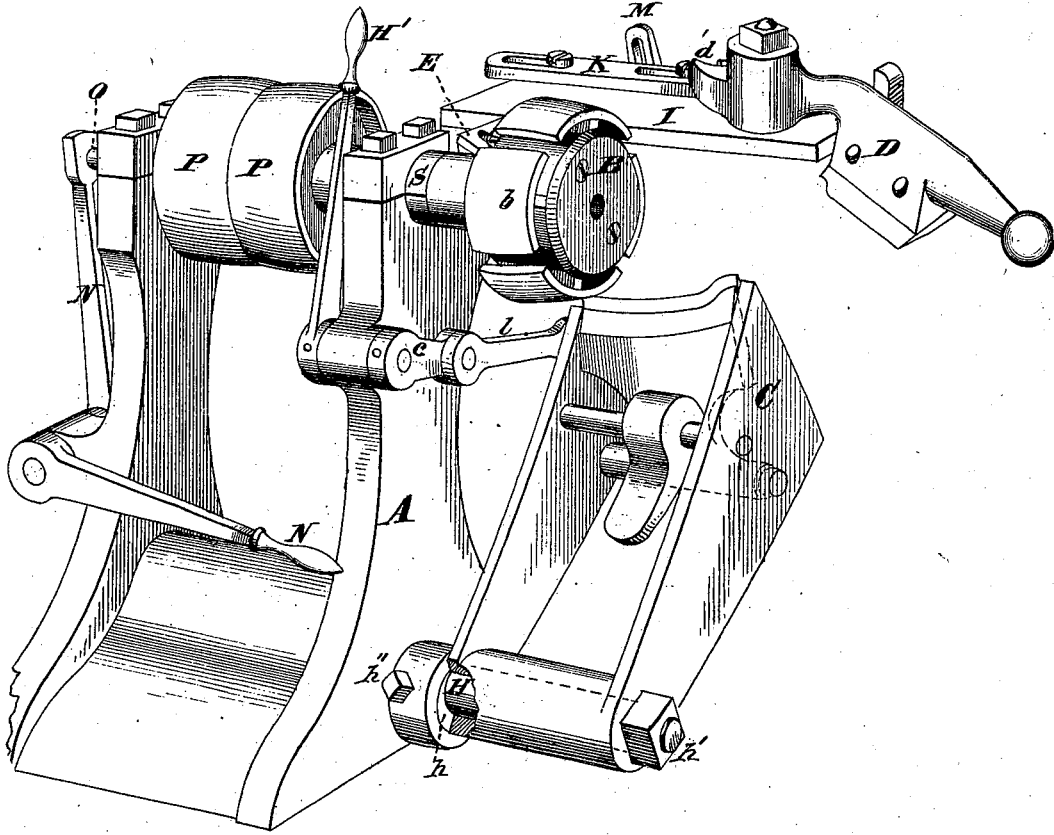
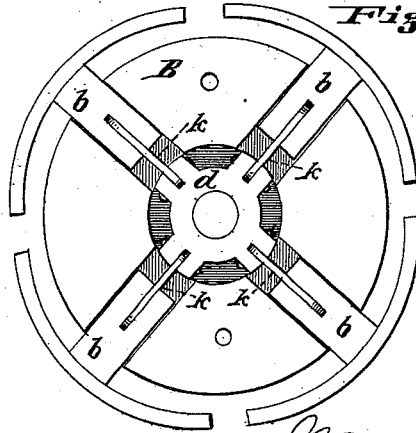

Fig. 2



Attest

*Edgar Cross*  
*John E. Jones.*

Inventor

*William Donaldson*  
*Pay F. Millward*  
*Attorney*

W. DONALDSON.  
Lathe for Turning Pottery-Ware.  
No. 197,616. Patented Nov. 27, 1877.

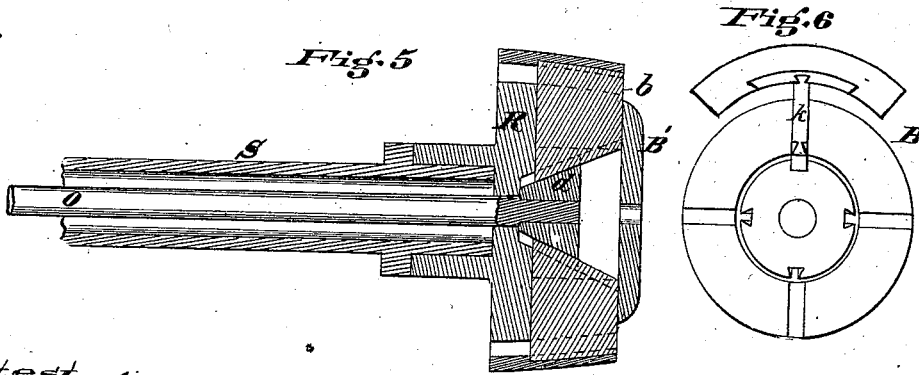
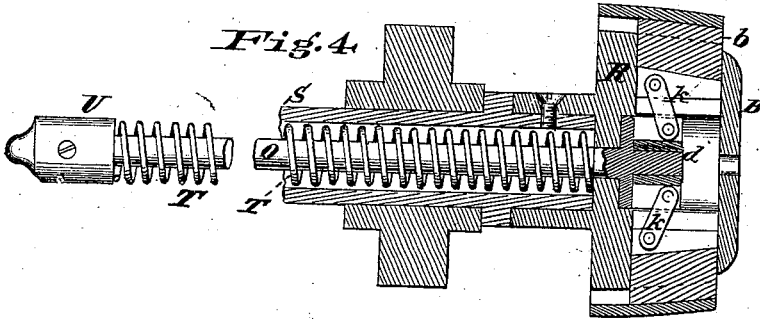
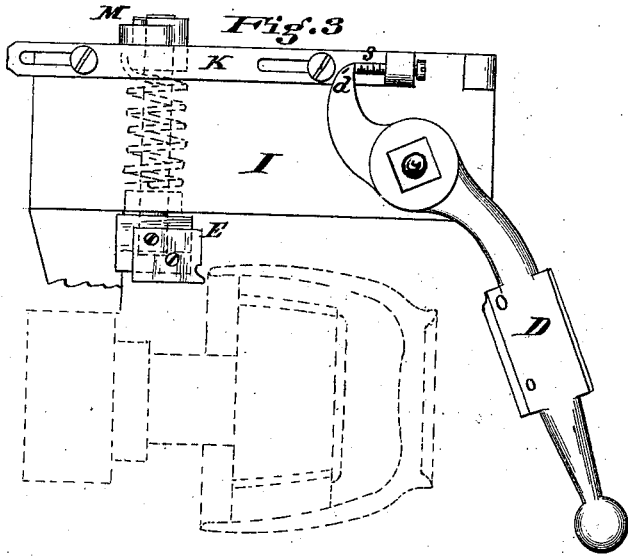

Attest  
Edgar Bros.  
John E. Jones

Inventor  
William Donaldson  
By Y. Millward  
Attorney

# UNITED STATES PATENT OFFICE.

WILLIAM DONALDSON, OF CINCINNATI, OHIO.

## IMPROVEMENT IN LATHES FOR TURNING POTTERY-WARE.

Specification forming part of Letters Patent No. **197,616**, dated November 27, 1877; application filed October 27, 1877.

### *To all whom it may concern:*

Be it known that I, WILLIAM DONALDSON, of Cincinnati, county of Hamilton, State of Ohio, have invented a Lathe for Turning Hollow Potter's Ware, of which the following is a specification:

My invention relates to that class of machines in use for turning cups, bowls, mugs, and other articles of potter's ware; and has for its object the production of a uniform configuration of ware by the use of unskilled labor.

My invention especially consists of certain peculiar mechanisms, hereinafter described, by means of which the piece of ware to be operated on is held.

My invention also consists of certain devices whereby the piece of ware is operated upon on both top and bottom simultaneously, thus insuring uniformity of product.

My invention further consists of certain means for holding and operating the knife or tool for turning the outside of the piece of ware.

In the construction of a machine embodying my invention there is mounted, in bearings upon a stand or head of suitable form, a hollow spindle, carrying on its inner projecting end a universally-expanding chuck, of such construction that, upon pressing upon a lever at the opposite end of the head or stand, the jaws of the chuck are caused to contract, so as to decrease the size of the chuck, consequently releasing anything that might have been theretofore secured upon it, and upon releasing the lever the jaws are made to expand, by means of a spring preferably adjustable in power, so as to gripe on the inside any hollow article that might be placed thereon, leaving the outside free to be operated on.

At the chuck end of the head there is a tool-holder, swinging on an eccentric-stud. This stud has its bearing near the base of the head, and has for its object the raising or lowering of the tool-holder for varying sizes of work, and also for adjusting the tool. The tool-holder carries a tool of the proper shape for turning the outside of the ware, and is brought to and from the work by means of a lever arm and link. At the back of the chuck, and secured to an arm of the head, is a bracket carrying two tool-holders, one of these for turning the

top or rim of the piece of ware, and the other for turning the foot and bottom. These are so arranged as to operate simultaneously and swing out of the way when not in use, so as not to interfere with putting on or taking off the work from the chuck. At the end of the head opposite the chuck is a bell-crank lever for the purpose of operating the chuck through the medium of a rod running through the hollow spindle. This rod connects with the jaws of the chuck by means of links, toggles, or equivalents, so arranged that when the rod is pressed inward the links cause the jaws to contract, and when the rod is released a spring on the rod causes the jaws to expand. This spring can be made strong or weak (by means of a nut on the rod) to adapt it to the nature of the work, and, in use, gives a constant predetermined pressure, yielding to the work.

In the accompanying drawings, forming part of this specification, Figure 1 is a perspective view of my invention, showing the relative position of all of the parts. Fig. 2 is an end view of the chuck with the cap removed, showing the rod that runs through the spindle, and the jaws and the links connecting the rod with the jaws. Fig. 3 shows the manner of operating and general arrangement of the topping and bottoming tools. Fig. 4 is an axial section of the chuck and part of the hollow spindle, showing clearly the operation of the links, also the manner of adjusting the spring that expands the jaws. Fig. 5 shows an equivalent method of operating the jaws from the rod and spring—viz., inclined planes acting by sliding into varying positions to expand and contract the jaws. Fig. 6 shows a means of making one chuck answer for several kinds and sizes of ware by changing the size and shape of the jaws by the use of auxiliary jaws, of wood, or metal, or gum.

Similar letters of reference indicate like parts.

A is the stand or head, carrying in suitable bearings the hollow spindle S. On the spindle S and between the bearings are the tight and loose pulleys P P. On the projecting end of the spindle S, at the right-hand end of the head A, is the chuck B. At the base of the head A, and under the chuck B, is a stud, H,

formed eccentrically upon a spindle, *h*, which can be rotated for adjustment in the head A, the stud carrying or supporting the tool-holder C. The stud H can be moved for adjustment by the use of a wrench on the nut *h'*, and secured by the set-screw *h''*, tapped through the boss, which projects from the head A. The tool-holder C is made to swing on the stud H to and from the work by means of the crank *c* and link *l*, which are operated by the handle H'. Immediately in the rear of the chuck B, and secured to an arm of the head A, is a plate, I, or bracket, on which is mounted the topping-tool holder E and the bottoming-tool holder D. These and their operation are shown to advantage in Fig. 3. At the left-hand end of the head A is a bell-crank lever, N, working in a bearing in the head A. This bell-crank lever is used to contract the jaws of the chuck, which is done by pressing with the hand on the horizontal arm of the lever when the upright arm takes against and pushes inward the rod O, running through the hollow spindle S. Upon releasing the lever the spring T causes the rod to return and the jaws to expand.

A very important part of my invention consists of the chuck B. This chuck, as will be seen by referring to Figs. 2 and 4, is made up of the body R, jaws or wings *b*, links *k*, and spindle O, with head *d*. In the body R are planed or cut grooves to receive the jaws, which are kept in place by the cap B'. The shank of the jaws is slotted or grooved to receive one end of the links *k*. The head *d* of the rod O is also slotted or grooved to correspond with the grooves in the jaws, and receives the other ends of the links *k*, each opposite pair of links thus constituting a toggle, which, on being straightened by the action of the spring T, causes the jaws to expand. When the action is reversed by pressing on the rod O, the links draw the jaws together. The spring T is preferably adjustable on the rod O by means of the removable abutment U, for the purpose of increasing or decreasing the gripe of the chuck B.

The jaws *b* may be caused to expand or contract in a like manner by the use of inclined planes, as shown in Fig. 5, and in some cases it may be preferable to work them in that manner. In case it should be desirable to use one chuck for a number of different sizes and shapes, it may be done by the use of auxiliary jaws, of wood, or metal, or gum, or wood or metal jaws faced with gum, which can be at-

tached to the stationary jaws by dovetail grooves or screws, as shown in Fig. 6.

To turn a piece of ware, the mode of procedure is as follows: The lever N is pressed with the left hand, thereby closing the jaws of the chuck B, on which, with the right hand, the piece to be turned is placed. The lever is then released, which allows the spring to expand the jaws and fasten the piece on the chuck. By then taking hold of the lever H' with the left hand, the tool in the holder C is steadily brought up so as to turn off the outside of the piece. Then, while the tool-holder C is still forward, the right hand steadily brings up the tool in the holder D to turn the bottom. While this is being done, the arm *d'* on the holder D comes in contact with the screw *s*, causing (through the medium of the slide K and slotted arm M) the vibratory head E to partially rotate, so as to bring the tool in the head E in contact with the top edge of the piece of ware. The piece of ware being thus finished, the left hand presses on the lever N, contracting the jaws, and at the same time the piece is removed with the right hand. As soon as the piece of ware is removed, the tool-holder C must be put back into its original position, when the operation may be repeated *ad infinitum*.

The tools in the holders C, D, and E may be secured in any of the usual ways that will admit of expeditious changing.

I claim—

1. In a lathe for turning potter's ware, a chuck for grasping the ware interiorly, whose jaws are operated simultaneously by a reciprocating axial rod actuated to produce the gripe by a spring, substantially as and for the purpose specified.

2. In combination with the rod O and spring T, for operating the jaws, the adjustable abutment U, substantially as and for the purpose specified.

3. In combination with a lathe having a chuck to interiorly grasp the ware, the swinging cutter-frame C, the topping-cutter E, and bottoming-cutter D, arranged substantially as described, and operating in the manner set forth.

In testimony of which invention I hereunto set my hand.

WILLIAM DONALDSON.

Witnesses:

EDGAR J. GROSS,  
JOHN E. JONES.