

F. GIBFORD.  
Car-Coupling.

No. 197,625.

Patented Nov. 27, 1877.

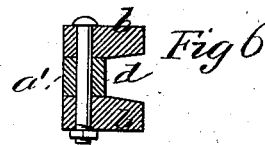
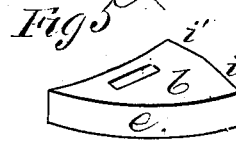
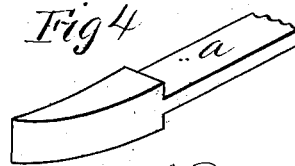
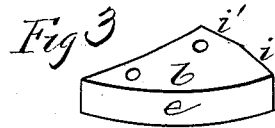
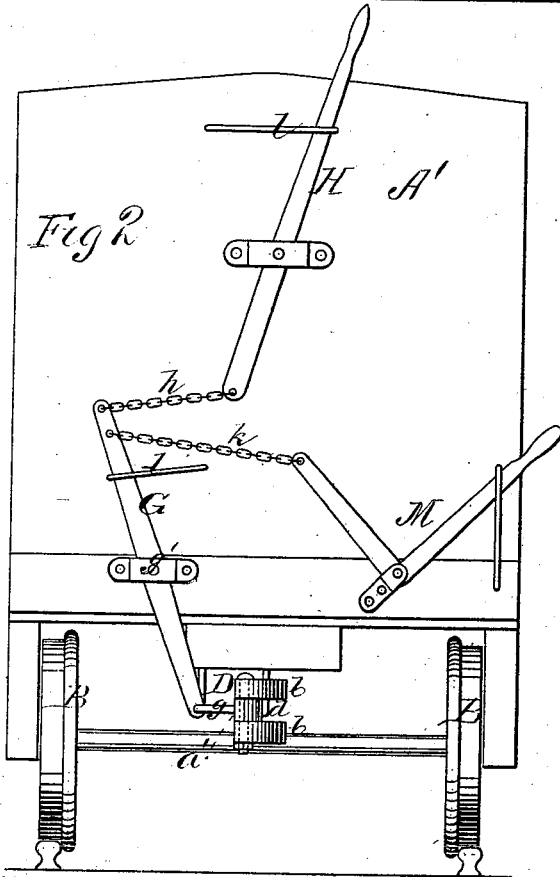
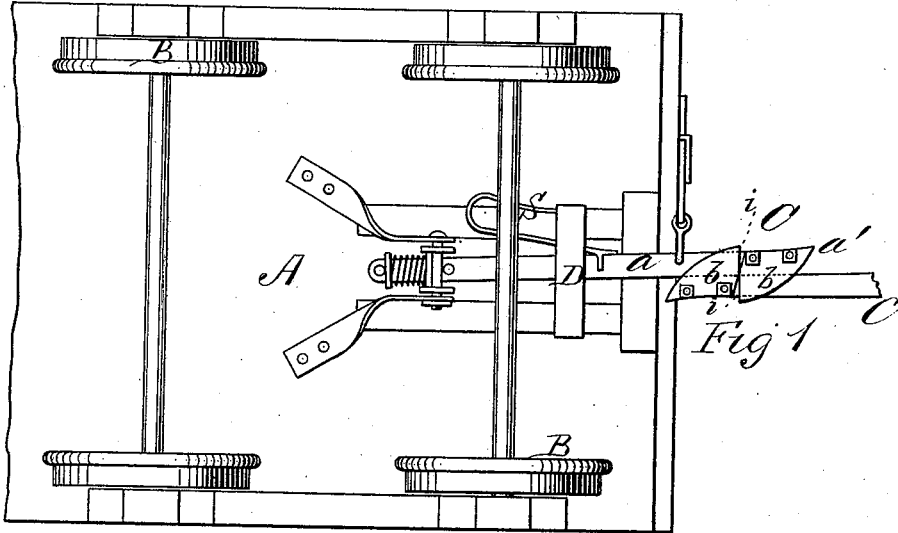

WITNESSES

Mary S. Utley.  
A. J. Chasi

INVENTOR

Frank Gibford  
by E. W. Anderson

ATTORNEY

# UNITED STATES PATENT OFFICE.

FRANK GIBFORD, OF NEWTON, IOWA, ASSIGNOR OF ONE-FOURTH OF HIS RIGHT TO URIAH GIBFORD, OF NEW YORK, N. Y.

## IMPROVEMENT IN CAR-COUPINGS.

Specification forming part of Letters Patent No. **197,625**, dated November 27, 1877; application filed November 3, 1877.

*To all whom it may concern:*

Be it known that I, FRANK GIBFORD, of Newton, in the county of Jasper and State of Iowa, have invented a new and valuable Improvement in Car-Couplings; and I do hereby declare that the following is a full, clear, and exact description of the construction and operation of the same, reference being had to the annexed drawings, making a part of this specification, and to the letters and figures of reference marked thereon.

Figure 1 of the drawings is a representation of a bottom view of a car with my improved coupling applied. Fig. 2 is an end view of the same; and Figs. 3, 4, 5, and 6 are detail views of the parts of the draw-bar.

This invention has relation to improvements in automatic couplings, wherein the coupling is effected by the interlocking of two laterally-movable barbed heads.

The nature of the invention consists in a draw-bar having enlarged locking-heads, composed of a shank and two spaced triangular plates, removably secured thereto upon its upper and lower horizontal faces, in the space between which flanges the shank of the draw-bar of the other car will be received when the coupling is effected, which plates may be readily removed when the shank or stem is broken or replaced when worn out.

It also consists in forming the rear end or heel of the plates aforesaid slightly beveled, so that when the heads are interlocked they will have a rocking or tangential bearing upon each other, which will cause the cars to be automatically uncoupled should one leave the track.

It also consists in certain novel and advantageous combinations of levers and flexible connections for throwing the heads out of engagement with each other, either from the top or sides of the car, as will be hereinafter more fully set forth.

In the annexed drawings, the letters A A' designate two ordinary cars, mounted in any known way upon the trucks of the transporting-wheels B. C represents my improved draw-bar, supported at or near the middle of its length by a depending stirrup, D, and secured to a depending post or bracket project-

ing downward from the car-body. The draw-bar is composed of a rectangular shank or stem, *a*, and an enlarged head, *a'*, composed of the beveled or rounded end of the stem, and two triangular metallic plates, *b*, which are secured, the one to the lower and the other to the upper horizontal face of the shank, thus forming a groove, *d*, extending from front to heel of the heads. The plates *b* are curved upon one of their faces, *e*, and are secured removably to the stem by means of bolts, extending through and through the head; or, in lieu of the bolts, I may use a rectangular key, extending downward through registering-slots in the plates and stem. The draw-bar has free horizontal vibratory motion with reference to the car. When, in the act of coupling, the curved faces of the heads come in contact, the draw-bars yield laterally, thereby allowing the said heads to pass each other; and when this is accomplished, they are forced back into their original positions, thereby causing the heads to interlock by a U-shaped metallic spring, S, secured at one end to the stirrup aforesaid, and bearing with the other against the shanks of the said draw-bars. The rear edge of the plates *b* is at right angles to the length of the shank from its outer edge to the edge of the said shank, as shown at *i*, but from the inner to the outer edge of the shank is beveled, as shown at *i'*; consequently, when the heads are interlocked, they have a rocking or rolling bearing upon each other, which allows a curve to be turned without twisting the plates, and gives a square bearing in so doing. The inner walls of the plates *b* are beveled, so that the channel between them is narrower at the bottom than at the top, the effect of which is to uncouple the cars in the event of their jumping the track.

The cars are uncoupled by means of a master-lever, G, connected at its lower end by a chain, *g*, to the draw-bar, and fulcrumed at *g'* to the end of the car. The power end of this lever is connected, by a chain, *h*, to a second lever, H, extending up beyond the top of the car, both of the said levers being extended through guides *l*. By thrusting lever H in a proper direction, it will, through the medium of the chain *g* and lever G, cause the draw-

bar to vibrate laterally and effect an uncoupling.

Lever G is connected, by means of a chain, *k*, with an angular vertically-vibrating lever, M, the power-arm of which extends beyond the side of the car. By thrusting lever M down, the draw-bar will swing laterally without affecting the lever H, owing to the flexibility of the chains *g k*. The triangular plates aforesaid, being removably secured to the shank or stem, may be renewed when broken or worn out, or transferred to another stem should the first stem be broken. By forming the draw-bar in sections, as above described, it may be made of wrought-iron, at a comparatively small expense, as its component parts may be forged at a blacksmith's instead of being rolled out.

Having described my invention, I claim as new and desire to secure by Letters Patent—

1. In combination with the draw-bar *a*, the detachable plates *b*, secured to the upper and lower surfaces of the draw-bar, substantially as specified.

2. The draw-head herein described, having the angular channeled head and the beveled heel *i'*, substantially as specified.

3. The laterally-vibrating draw-bar C, the master-lever G, and the chain *g*, the top lever H, the chain *h*, the side angular lever M, and chain *k*, operating as and for the purpose specified.

In testimony that I claim the above I have hereunto subscribed my name in the presence of two witnesses.

FRANK GIBFORD.

Witnesses:

CHAS. W. HANDY,  
F. J. MASI.