

J. F. MILLIGAN.  
Means for Cooling Circular-Saws.

No. 197,650.

Patented Nov. 27, 1877.

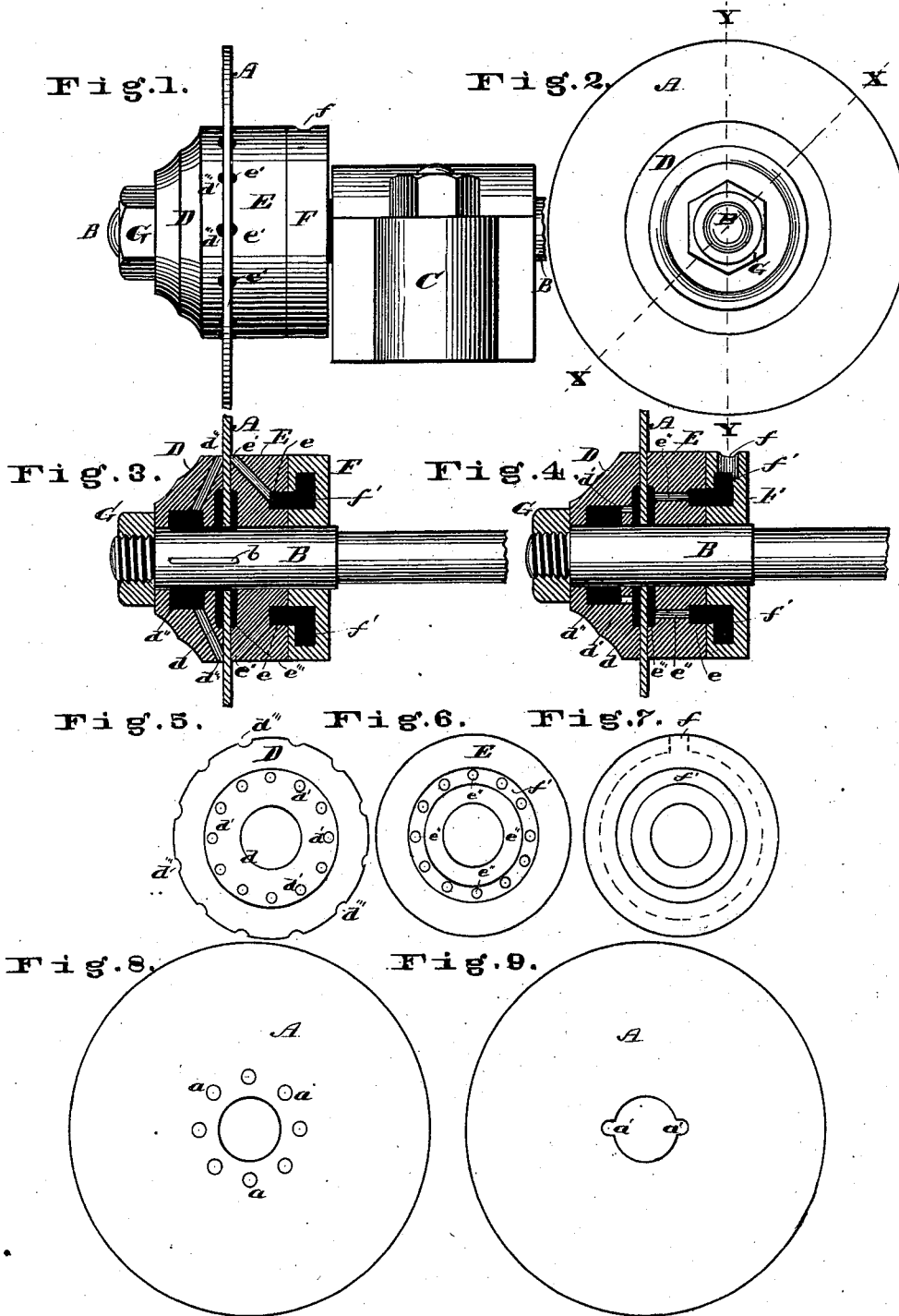

WITNESSES.

*Saml. S. Boyd*  
*W. F. Cozzens*

INVENTOR.

*John F. Milligan*  
*By Chas. D. Moody*  
*atty.*

# UNITED STATES PATENT OFFICE.

JOHN F. MILLIGAN, OF ST. LOUIS, MISSOURI, ASSIGNOR TO JOSEPH W. BRANCH, OF SAME PLACE.

## IMPROVEMENT IN MEANS FOR COOLING CIRCULAR SAWS.

Specification forming part of Letters Patent No. **197,650**, dated November 27, 1877; application filed March 4, 1876.

*To all whom it may concern:*

Be it known that I, JOHN F. MILLIGAN, a resident of the city and county of St. Louis, State of Missouri, have invented a new and useful Improvement in Cooling and Lubricating Circular Saws, of which the following is a full, clear, and exact description, reference being had to the annexed drawing, making part of this specification, in which—

Figure 1 is a side elevation of the invention in position; Fig. 2, an end elevation; Fig. 3, a central longitudinal section taken on the line *x x* of Fig. 2; Fig. 4, a similar section taken on the line *y y* of Fig. 2; Fig. 5, a view of the inner face of the outer collar; Fig. 6, a view of the inner face of the inner collar; Fig. 7, a view of the outer face of the loose collar; and Figs. 8 and 9, views of modifications of the saw-blade.

Like letters indicate like parts.

The aim of the present invention is to provide means for readily and effectually lubricating and cooling a circular saw; and it consists in the construction hereinafter described, by which a current of water or other suitable fluid is introduced at the central part of the saw, from whence it is distributed upon the saw to its periphery.

Referring to the annexed drawing, A represents the central part of a circular saw; B, the saw shaft or mandrel, and C the usual bearing therefor. D represents the outer collar, and E the inner collar. These collars turn with the saw and shaft in the ordinary way. F represents another collar arranged immediately inside the inner collar E, but it is loose on the shaft B and does not turn with it. This collar F is perforated at *f*, Figs. 1, 4, and 7, the perforation leading into an annular chamber, *f'*, Figs. 3, 4, and 7, which extends into the collar E from the outer face thereof. In the inner face of the collar E is also an annular chamber, *e*, which, when the parts of the invention are in position, coincides with the chamber *f'*. From the chamber *e* two series of passages, *e'* and *e''*, extend through the collar E, and in the following manner: one series, *e' e'*, &c., Fig. 3, outward to the periphery of the collar at the outer corner thereof; the other series, *e'' e''*, &c., Figs. 4 and 6, hori-

zontally through the collar into a chamber, *e'''*, in the outer face of the collar and surrounding the shaft B. In the collar D, and in the inner face thereof, is a chamber, *d*, similar to the chamber *e'''*, and also surrounding the shaft B. From this chamber *d* a series of passages, *d' d'*, &c., Figs. 4 and 5, extend horizontally to another chamber, *d''*, in the outer part of the collar D, and also surrounding the shaft B. From this last-named chamber, *d''*, a series of passages, *d''' d'''*, &c., extend to the periphery of the collar D, at the inner corner thereof. G represents the usual nut at the end of the shaft. The shaft is provided with grooves *b b*, extending from a point opposite the chamber *e'''*, (when the collar E is in place,) as far as and opposite the chamber *d''* in the collar D. The saw-blade is provided with a series of perforations, *a a*, &c., Fig. 8, and also with notches *a' a'*, &c., Fig. 9, leading from the eye of the blade.

The operation of the invention is as follows: The parts of the construction being in position, the loose collar F is brought closely against the inner collar E. A current of water is then, through the perforation *f*, admitted to the chamber *f'*, whence it passes into the chamber *e*. From this chamber the current diverges, part of it passing through the passages *e' e'*, &c., onto the inner side of the saw-blade, and part through the passages *e'' e''*, &c., chamber *e'''*, perforations *a a*, &c., chamber *d*, passages *d' d'*, &c., chamber *d''*, and passages *d''' d'''*, &c., onto the outer side of the saw-blade. The hub of the saw is not only cooled by this flow of water through it, but the saw-blade, also, is cooled and lubricated by the outward flow of the water to the periphery of the saw.

Instead of passing the water through the perforations *a a*, &c., in the saw-blade, it may be sent partly, or entirely, through the notches *a' a'*, &c., or it may be sent through the grooves *b b*, &c., in the saw-shaft, for I do not wish to be confined to any one of the means shown for passing the current to the outer side of the saw.

If desired, also, the chamber *d* may be enlarged so as to include the chamber *d''*.

I am aware that saw arbors or mandrels have been made hollow, forming a chamber

therein, which communicated, in one construction, with grooves in the inner faces of the collars embracing the saw, and, in another construction, with passages leading through the inner collar, but away from the saw-blade.

As a primary object with me is to avoid the expense of perforating the mandrel, and to provide a construction adaptable to the ordinary saw-mandrel, the constructions referred to would not answer my purpose, even if new with me, and I disclaim them.

Having described my invention, what I claim is—

1. The combination of the collar F, perforation *f*, chamber *f'*, collar E, chamber *e*, and shaft B, substantially as described.

2. The combination of the collar F, perforation *f*, chamber *f'*, collar E, chamber *e*, passages *e' e'*, &c., and shaft B, substantially as described.

3. The combination of the collar F, perforation *f*, chamber *f'*, collar E, chamber *e*, pas-

sages *e' e'*, &c., chambers *e''' d*, and *d''*, passages *d''' d'''*, &c., saw A, perforations *a a*, &c., and shaft B, substantially as described.

4. The combination of the collar F, perforation *f*, chamber *f'*, collar E, chamber *e*, passages *e' e'*, and chamber *e'''*, substantially as described.

5. The combination of the chambers *e'''* and *d*, shaft B, saw A, and perforations *a a*, &c., substantially as described.

6. The combination of the collars D and E, chambers *e e''' d d''*, passages *e' e' d' d'''*, shaft B, saw A, and perforations *a a*, &c., substantially as described.

7. The combination of the collars D, E, and F, perforation *f*, chambers *f' e e''' d d''*, passages *e' e' d' d'''*, shaft B, saw A, and perforations *a a*, &c., substantially as described.

JOHN F. MILLIGAN.

Witnesses:

CHAS. D. MOODY,  
GEORGE WORSTENHOLM.