

S. D. TUCKER.

Sheet-Delivering Apparatus for Printing-Machines.  
No. 197,693. Patented Nov. 27, 1877.

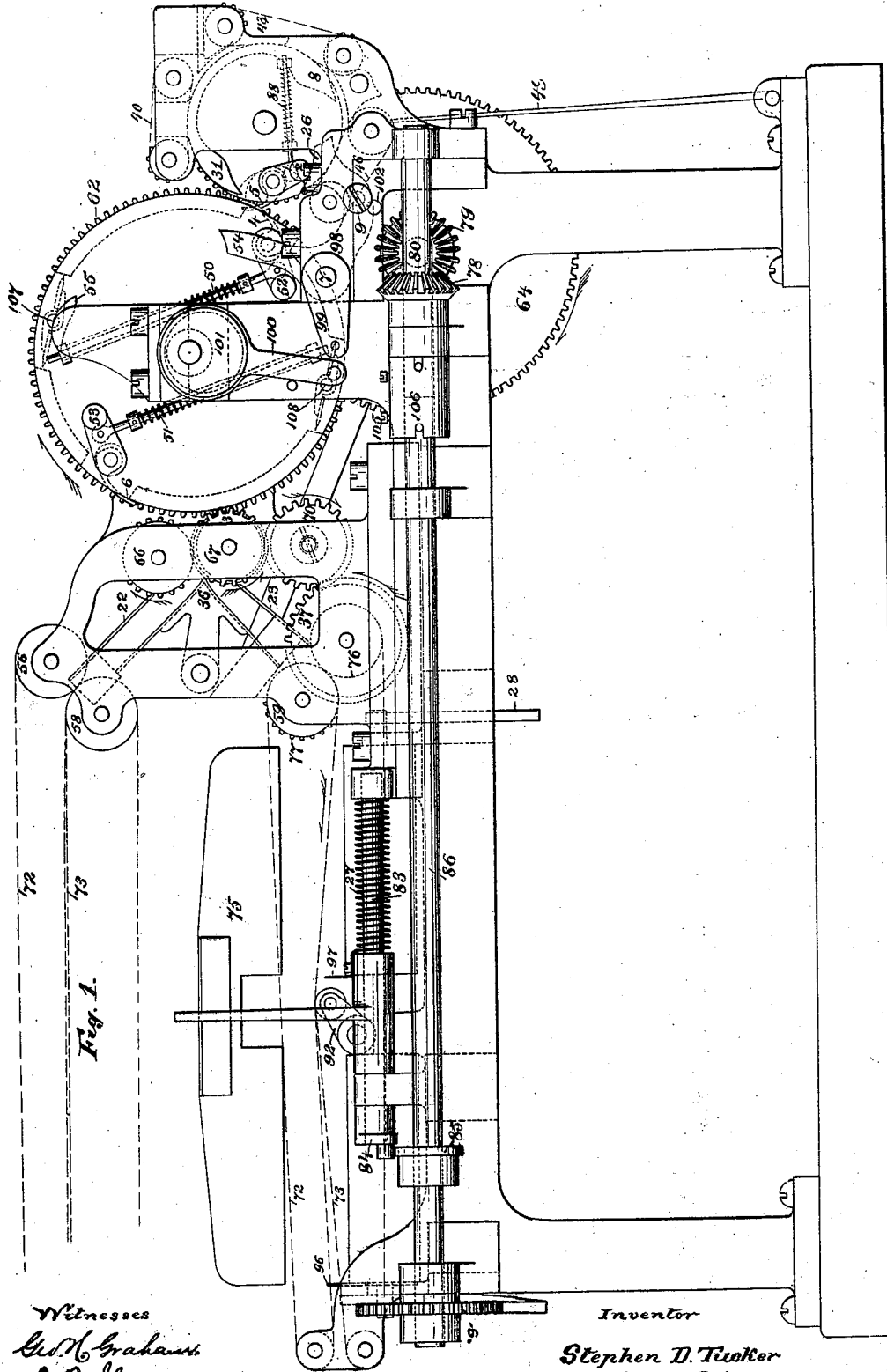

Fig. 1.

Witnesses  
Geo. M. Graham  
J. R. Ely

Inventor  
Stephen D. Tucker  
By Munn & Philipp  
ATTORNEYS

S. D. TUCKER.  
Sheet-Delivering Apparatus for Printing-Machines.  
No. 197,693. Patented Nov. 27, 1877.

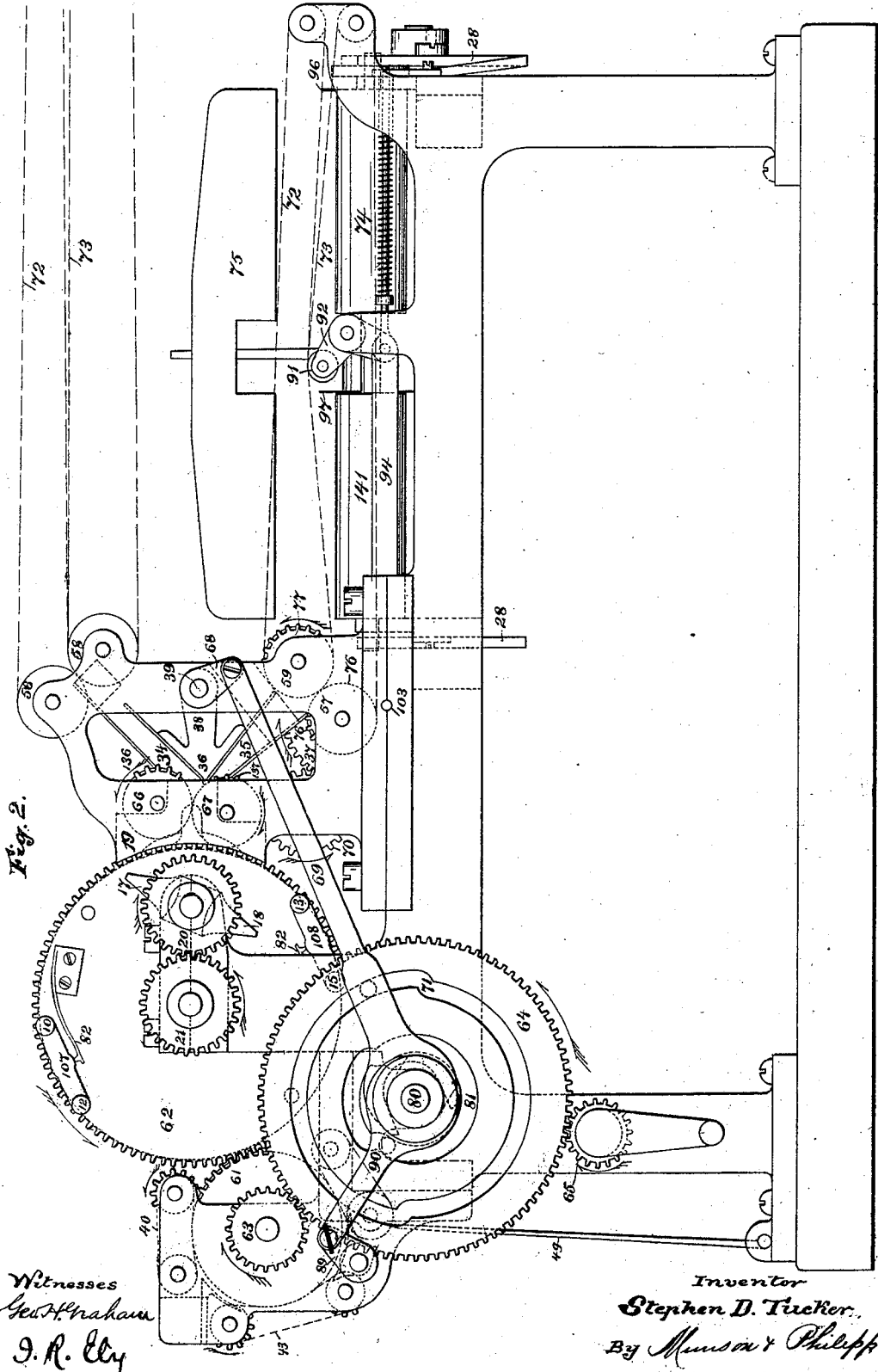
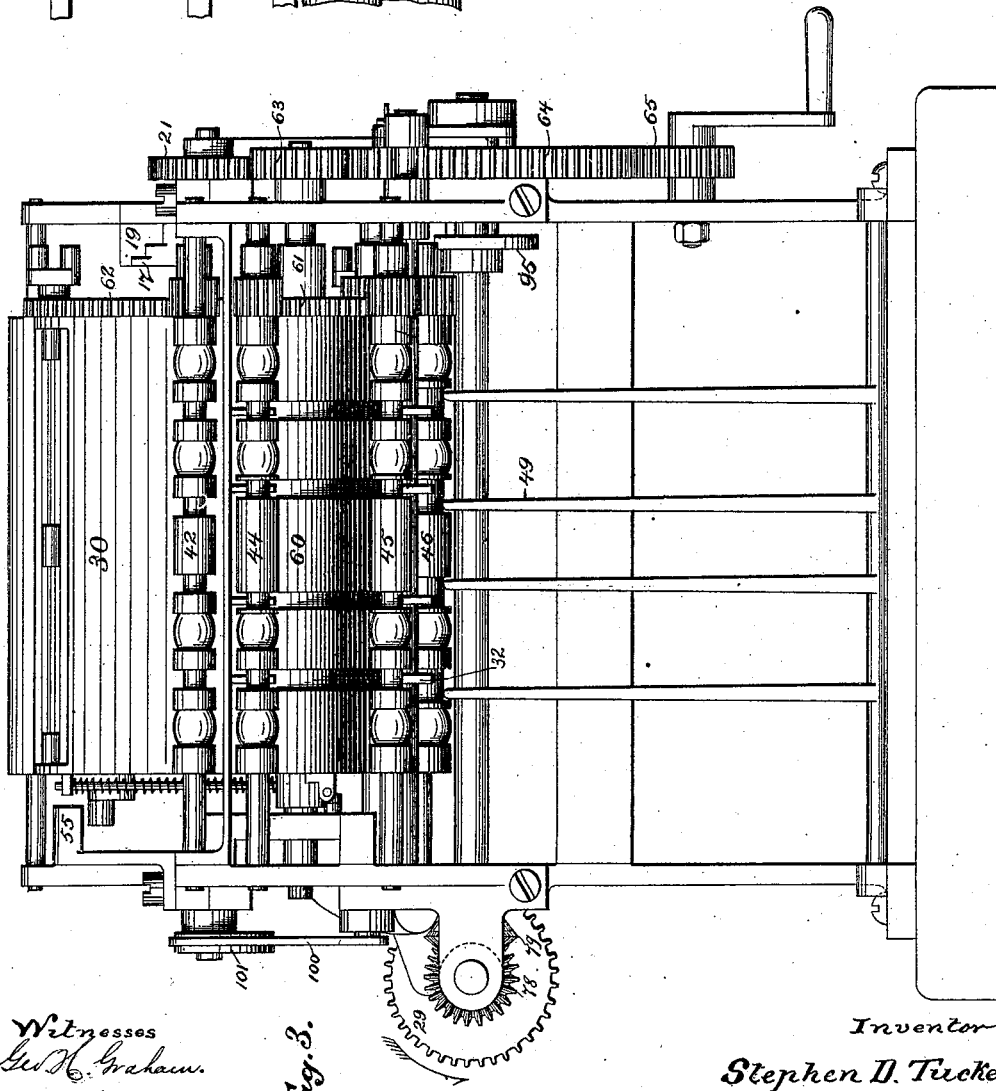
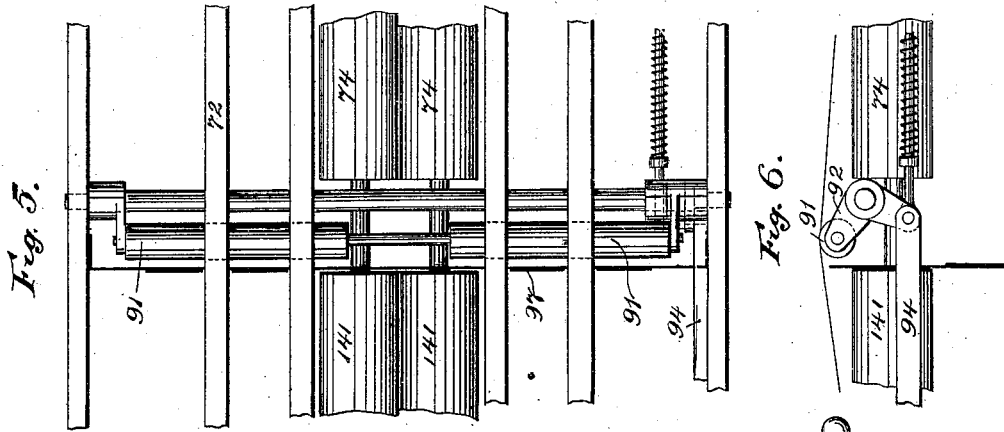

Fig. 2.

Witnesses  
Geo. H. Graham  
J. R. Ely

Inventor  
Stephen D. Tucker.  
By Munson & Phelps.  
ATTORNEYS

S. D. TUCKER.  
Sheet-Delivering Apparatus for Printing-Machines.  
No. 197,693. Patented Nov. 27, 1877.



Witnesses  
*G. H. Graham.*  
*J. R. Ily*

Fig. 3.

Inventor  
*Stephen D. Tucker*  
 By *Munson & Philipp*  
 ATTORNEYS

S. D. TUCKER.

Sheet-Delivering Apparatus for Printing-Machines.  
No. 197,693. Patented Nov. 27, 1877.

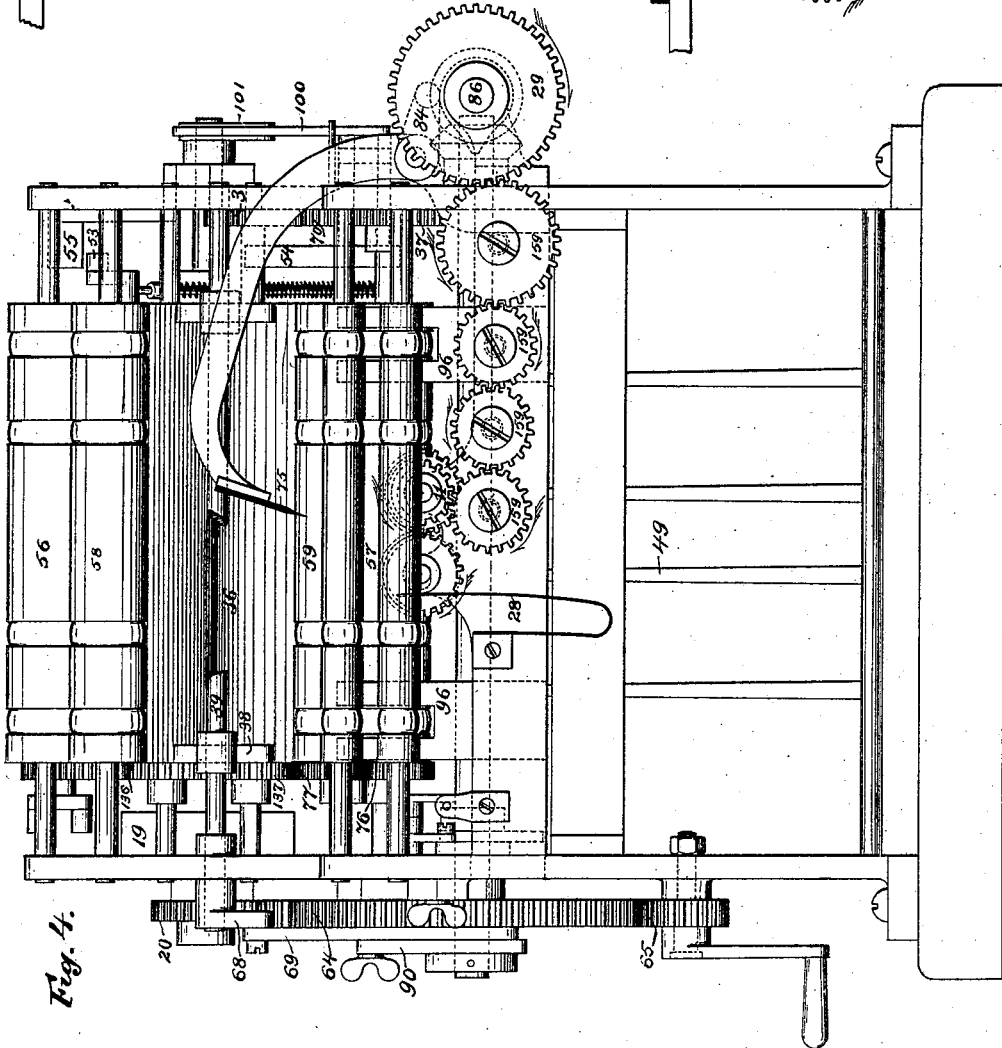
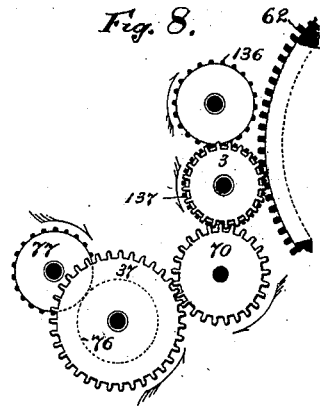
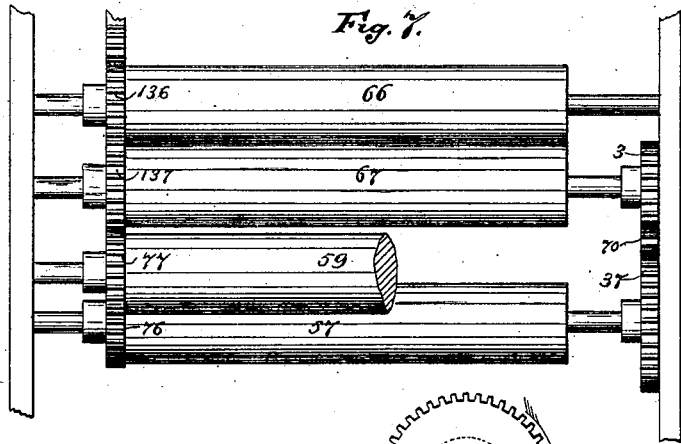

Fig. 4.

Witnesses  
*G. H. Graham.*  
*J. R. Ely*

Inventor  
**Stephen D. Tucker**  
 By *Munson & Phillips*  
 ATTORNEYS

S. D. TUCKER.  
Sheet-Delivering Apparatus for Printing-Machines.  
No. 197,693. Patented Nov. 27, 1877.

Fig. 10.

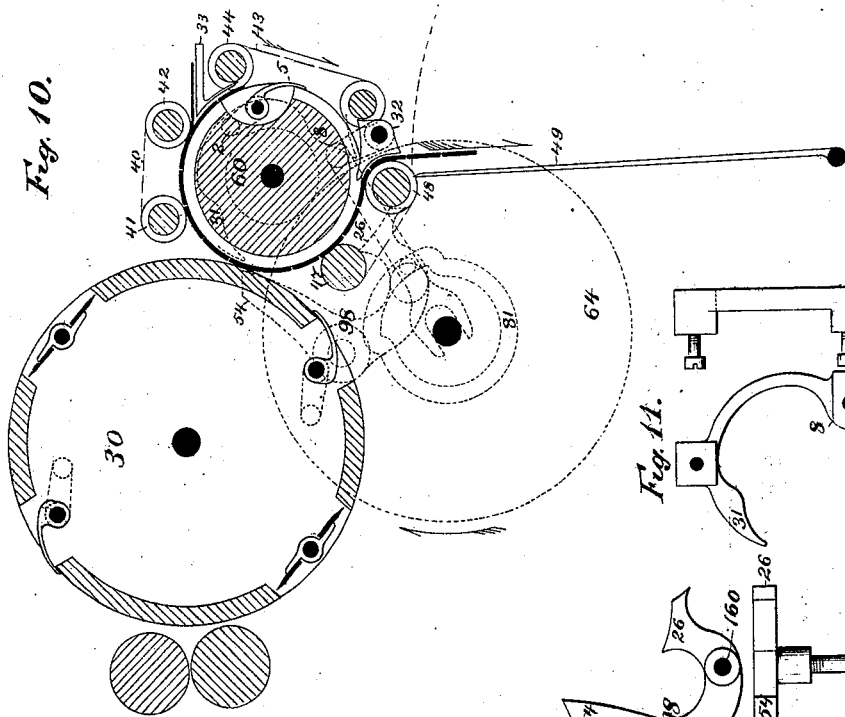

Fig. 9.

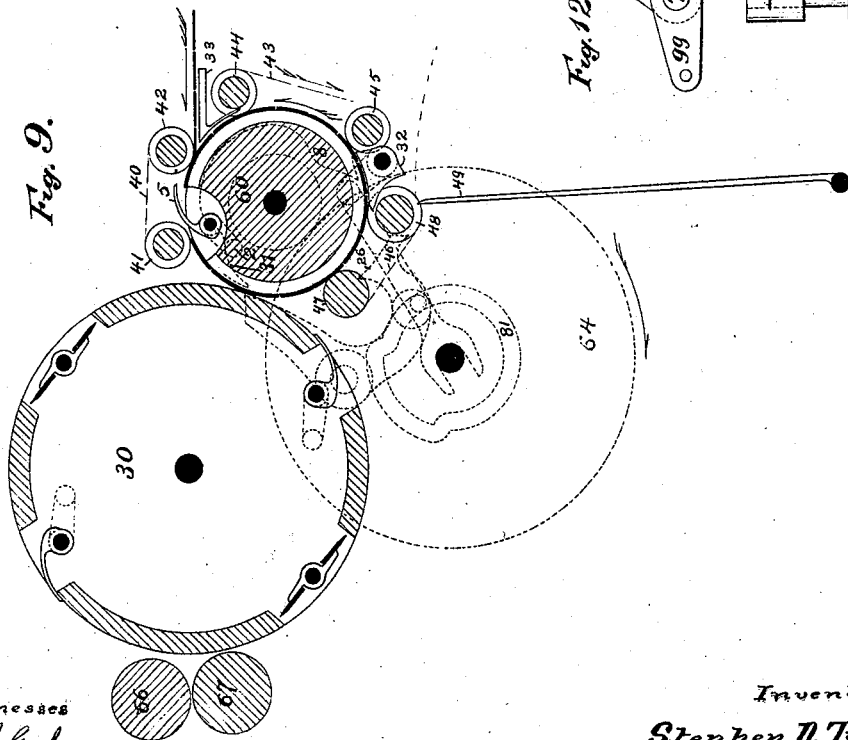

Fig. 11.

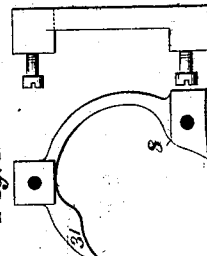
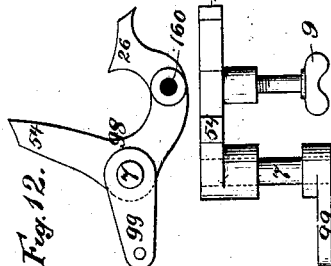

Fig. 12.



Witnesses  
G. H. Graham  
J. R. Ely

Inventor  
Stephen D. Tucker  
By *Mason & Philipp*  
ATTORNEY

S. D. TUCKER.  
Sheet-Delivering Apparatus for Printing-Machines.  
No. 197,693. Patented Nov. 27, 1877.

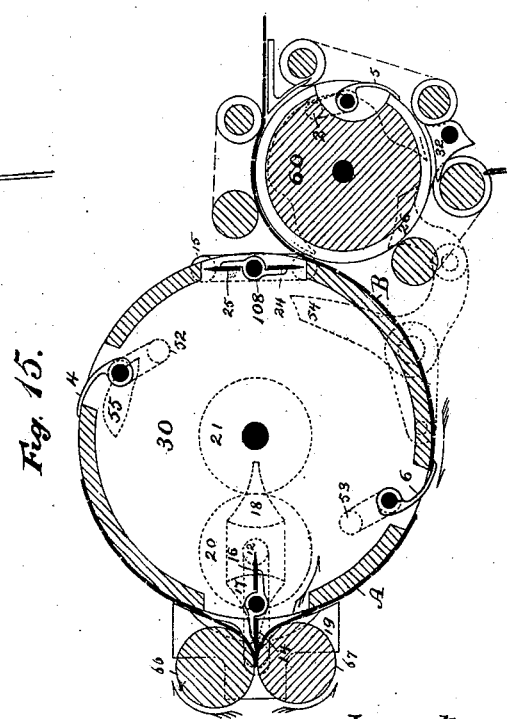
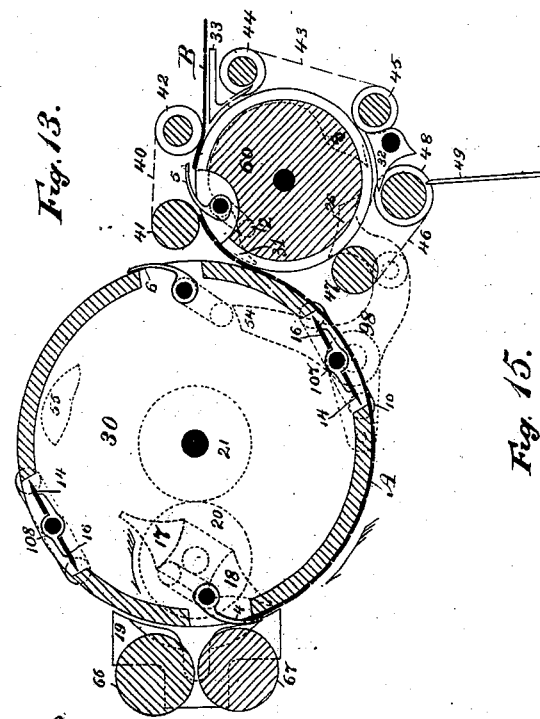
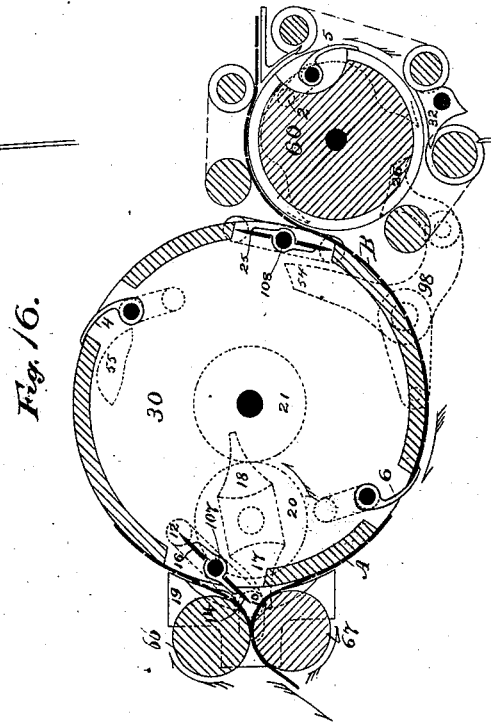
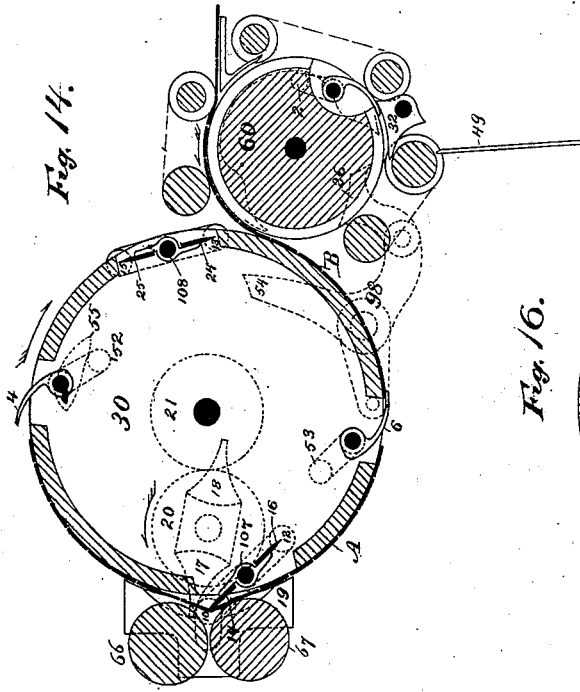

Witnesses  
*W. B. Graham*  
*J. R. Ely*

Inventor  
*Stephen D. Tucker*  
 By *Munroe & Philipp*  
 ATTORNEYS

S. D. TUCKER.

Sheet-Delivering Apparatus for Printing-Machines.  
No. 197,693. Patented Nov. 27, 1877.

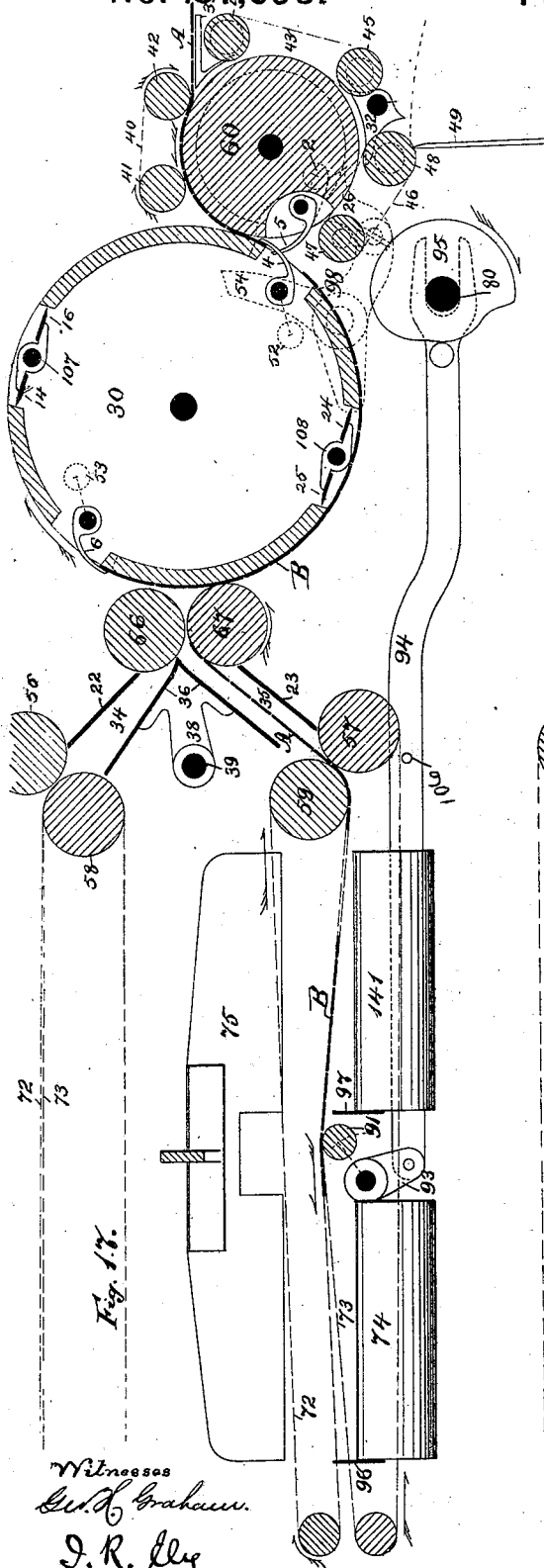

Witnesses  
*G. H. Graham.*  
*J. R. Day*

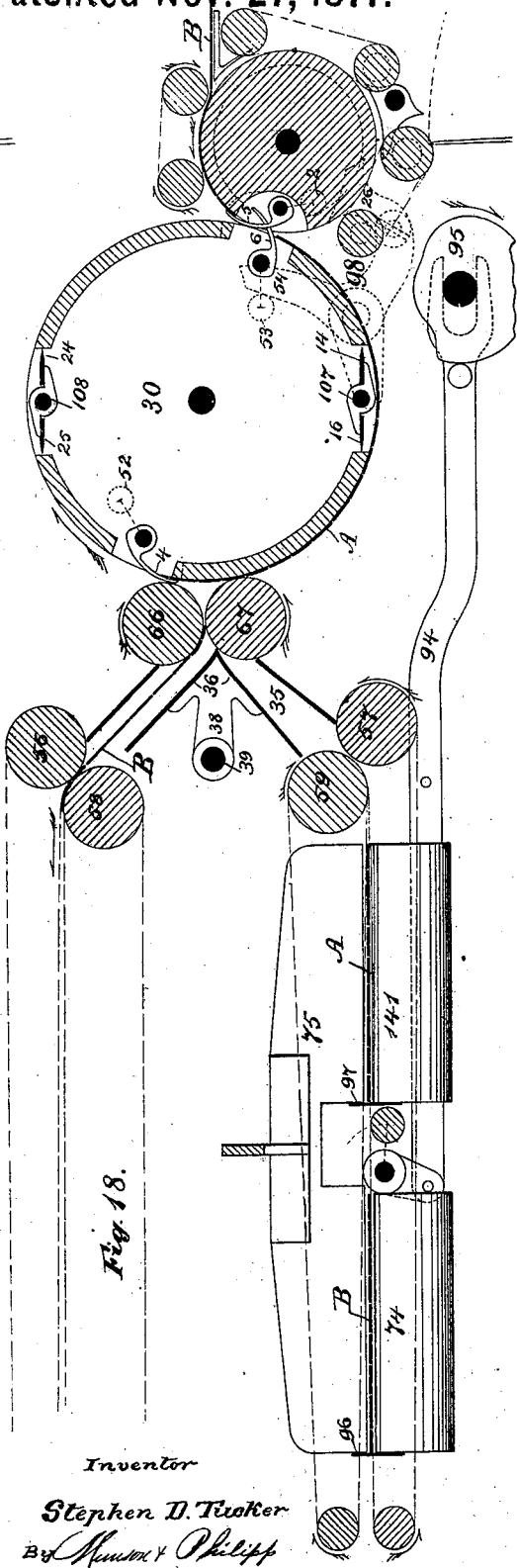

Inventor  
*Stephen D. Tucker*  
*By Samuel & Philipp*  
 ATTORNEYS

S. D. TUCKER.  
Sheet-Delivering Apparatus for Printing-Machines.  
No. 197,693.  
Patented Nov. 27, 1877.

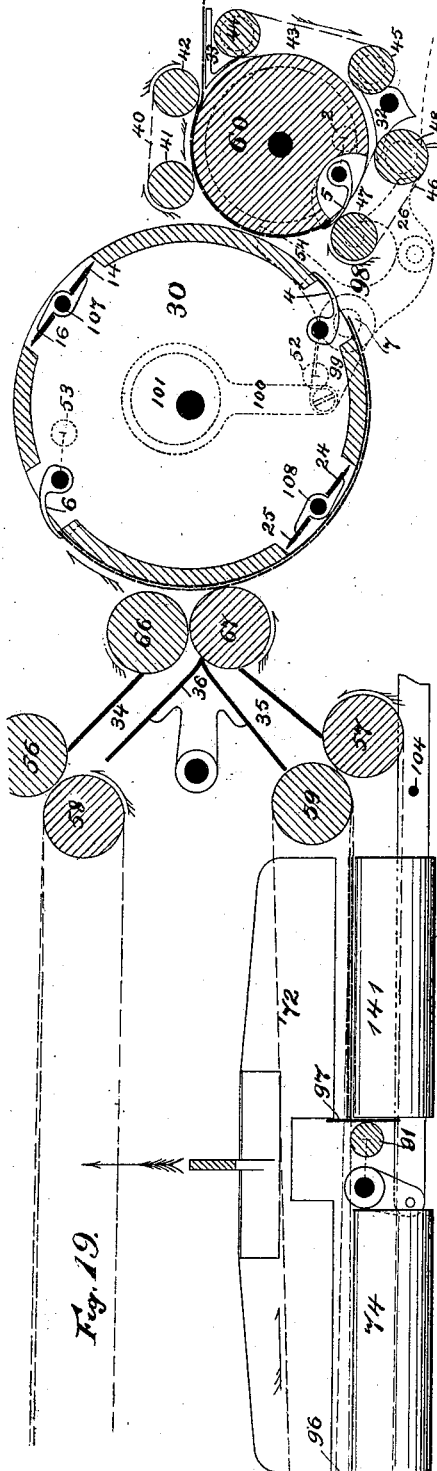

Fig. 19.

Witnesses  
G. H. Graham.  
J. R. Ely

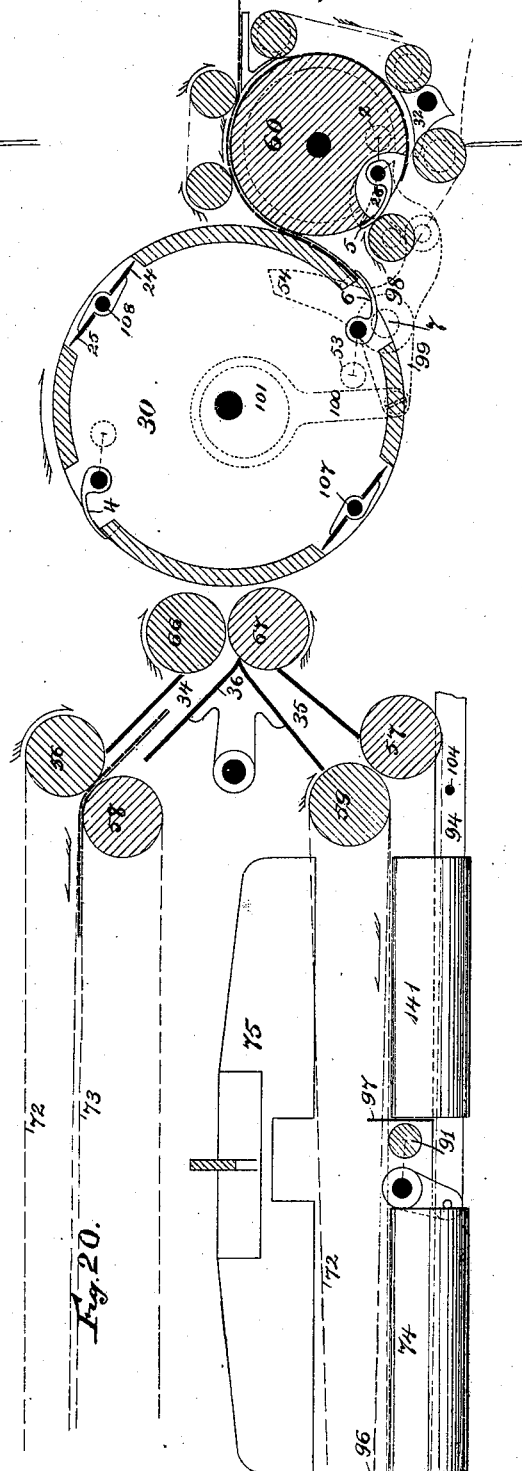

Fig. 20.

Inventor  
Stephen D. Tucker  
By Messrs. & Philipps.  
ATTORNEYS



S. D. TUCKER.  
Sheet-Delivering Apparatus for Printing-Machines.  
No. 197,693. Patented Nov. 27, 1877.

Fig. 21.

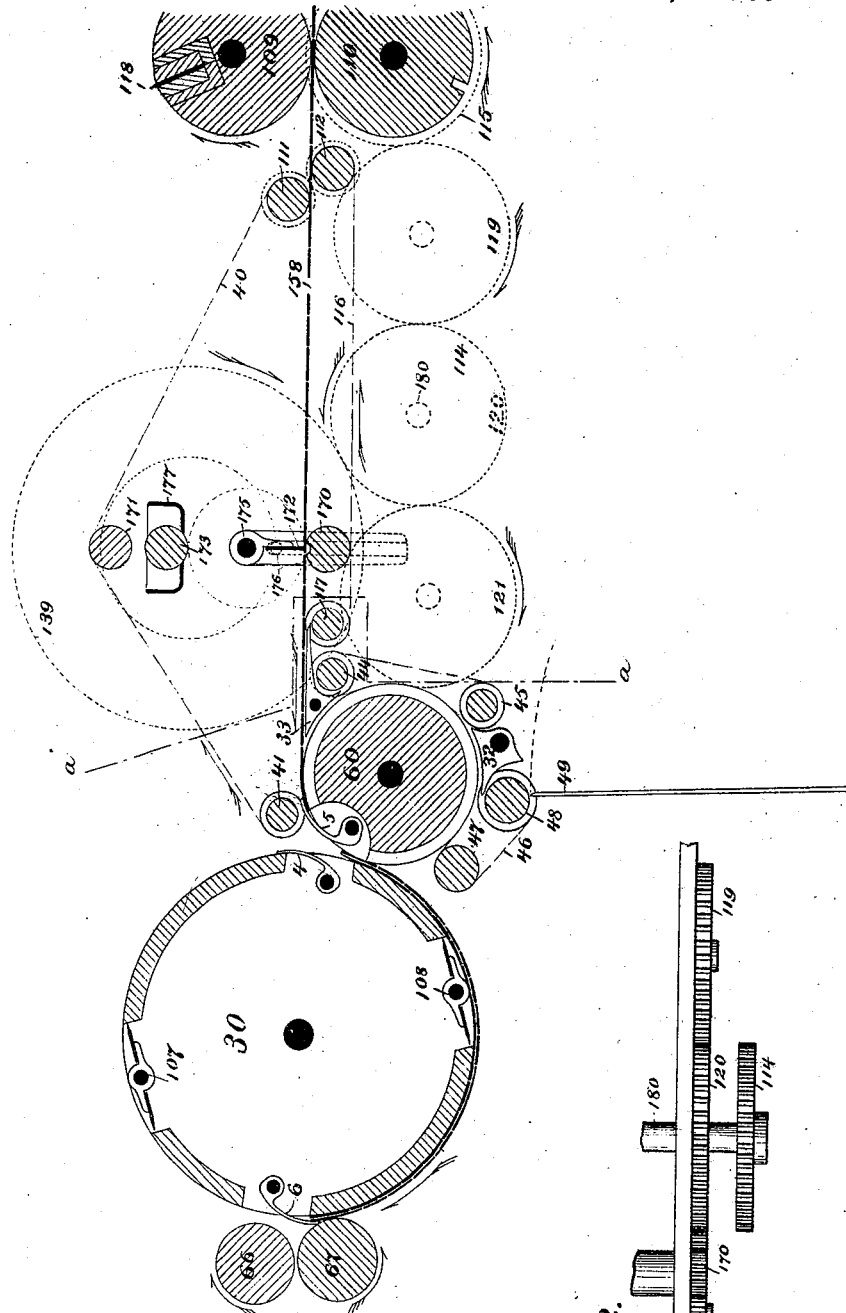
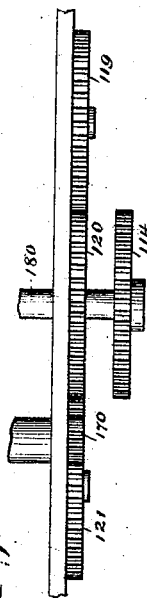

Fig. 22.



Witnesses  
*Geo. H. Graham*  
J. R. Ely

Inventor  
*Stephen D. Tucker,*  
By *Amos K. Phillips,*  
ATTORNEY

S. D. TUCKER.  
Sheet-Delivering Apparatus for Printing-Machines.  
No. 197,693. Patented Nov. 27, 1877.

Fig. 23.

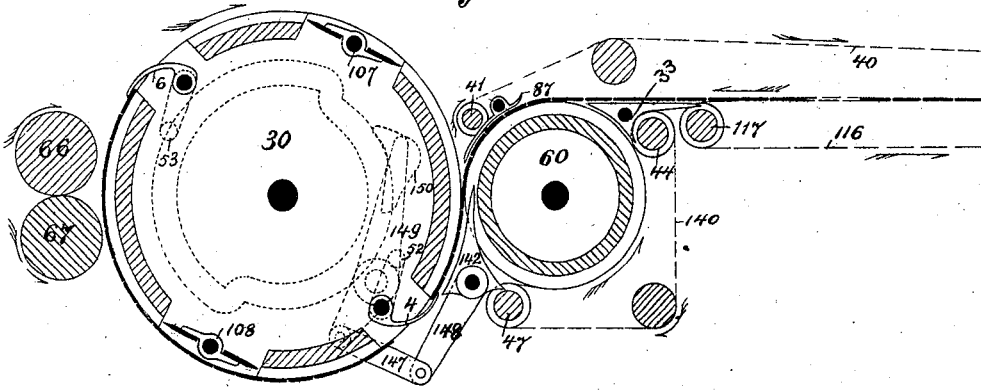

Fig. 24.

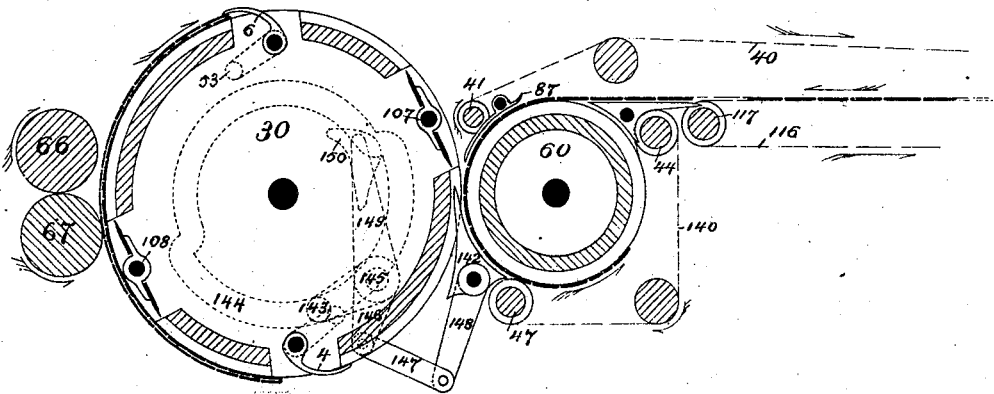
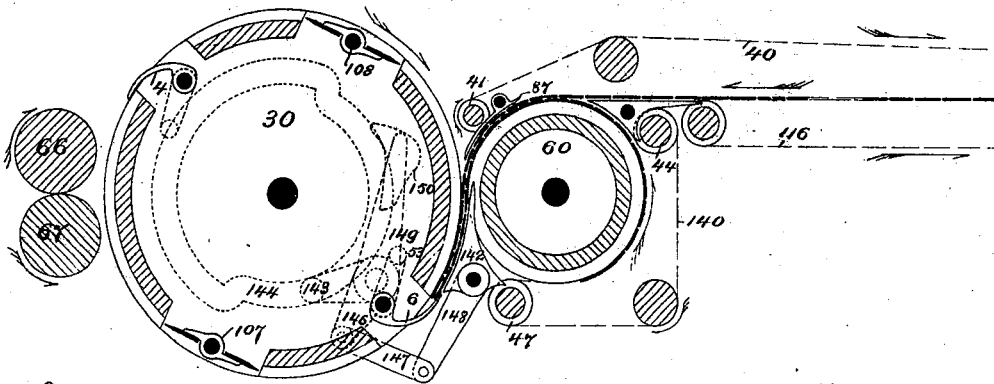

Fig. 25.



Witnesses  
*Geo. B. Graham*  
*J. R. Ely*

Inventor  
*Stephen D. Tucker*  
By *Munson & Phillips*  
ATTORNEYS.

S. D. TUCKER.  
Sheet-Delivering Apparatus for Printing-Machines.  
No. 197,693. Patented Nov. 27, 1877.

Fig. 26.

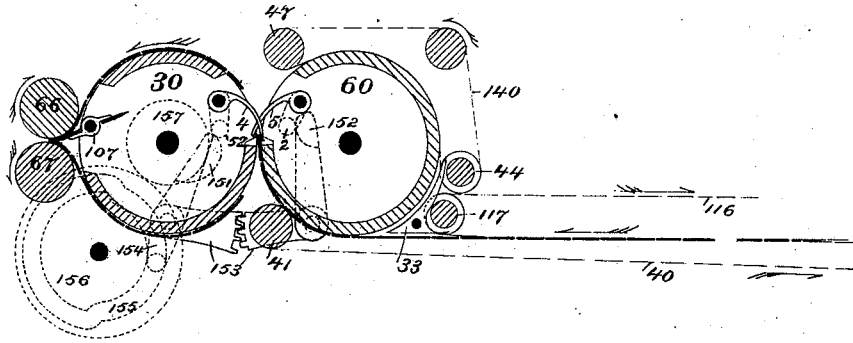

Fig. 27.

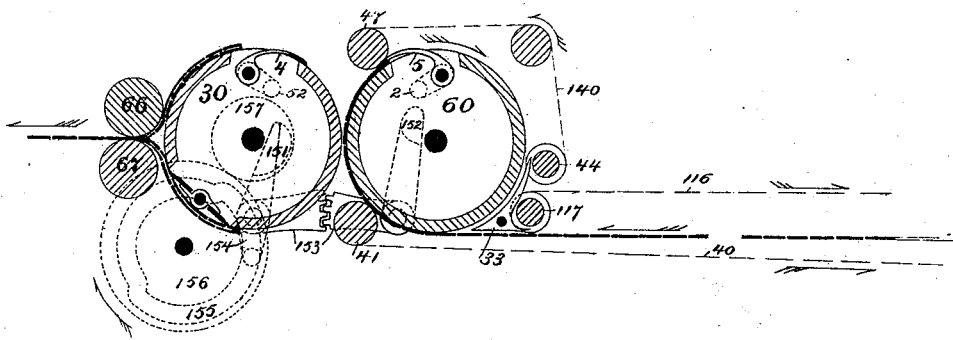
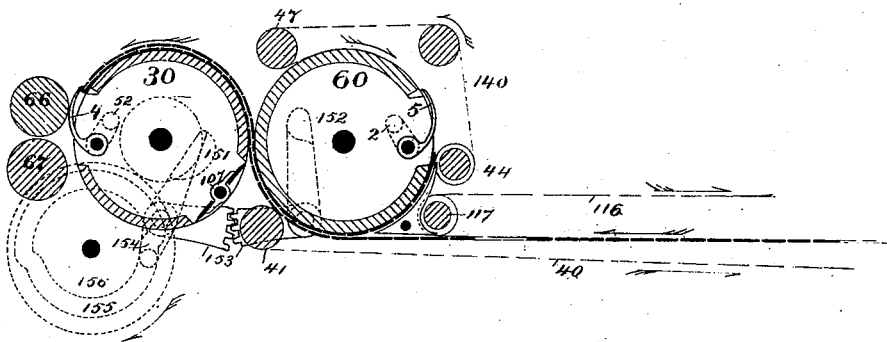

Fig. 28.



Witnesses  
Geo. H. Graham.  
J. R. Ely

Inventor  
Stephen D. Tucker  
By *Manum & Phillips*  
ATTORNEYS

S. D. TUCKER.  
Sheet-Delivering Apparatus for Printing-Machines.  
No. 197,693.  
Patented Nov. 27, 1877.

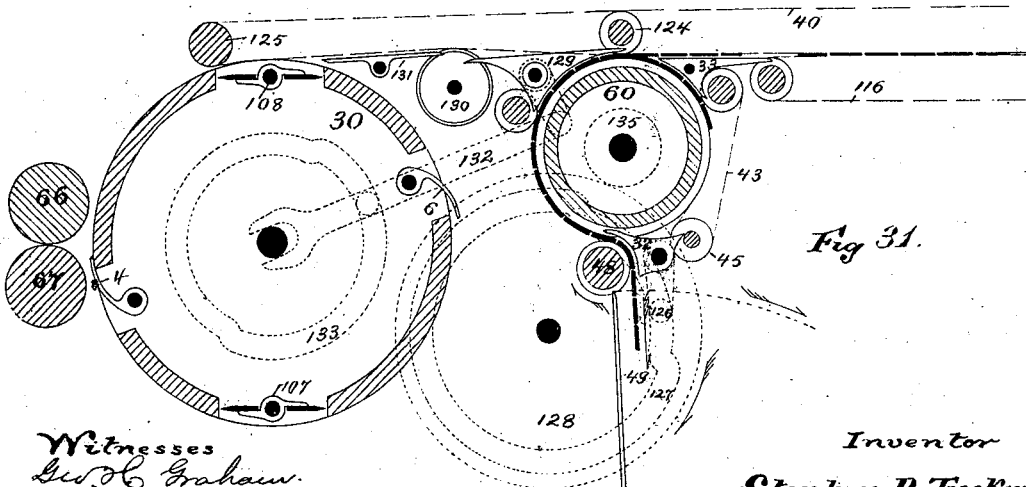
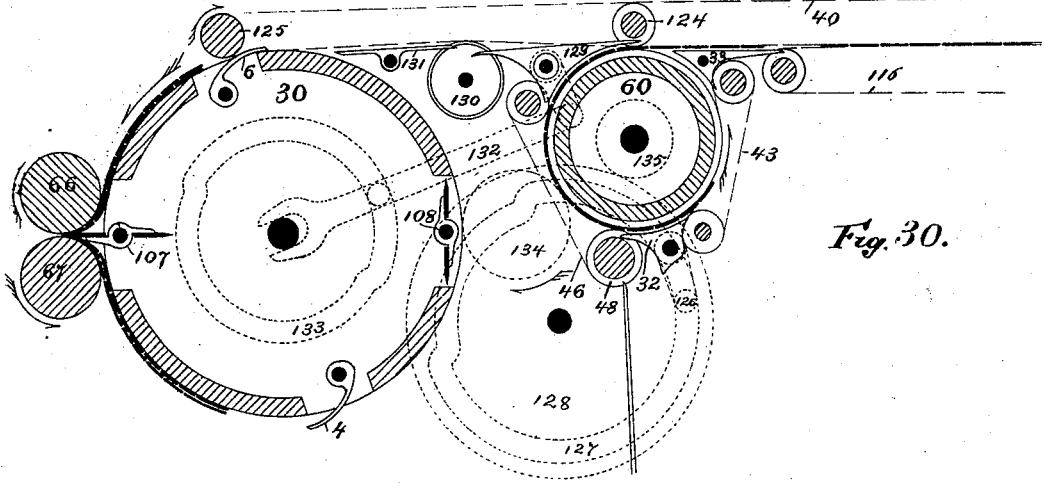
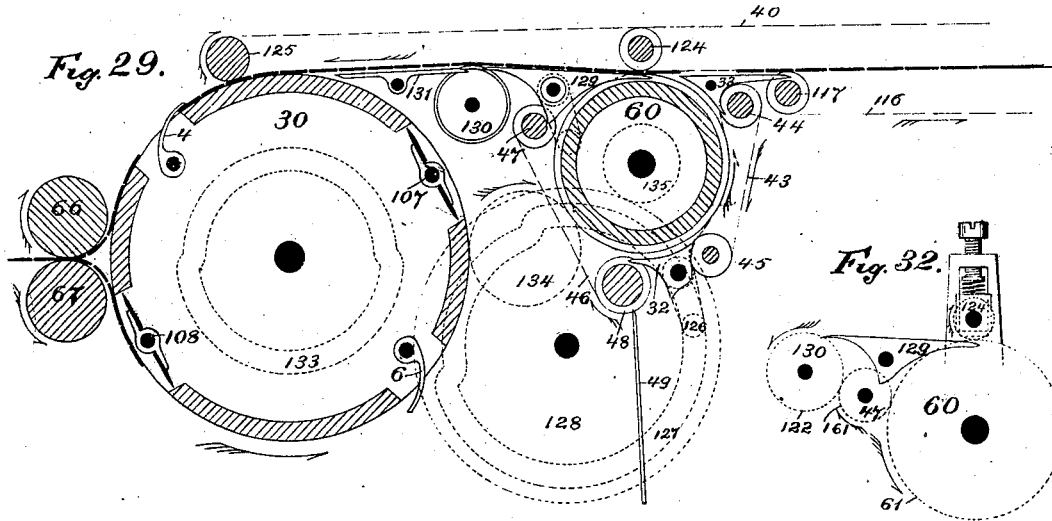

Witnesses  
G. H. Graham.  
J. R. Ely

Inventor  
Stephen D. Tucker  
By *Mason & Philipp*  
ATTORNEYS

S. D. TUCKER.  
Sheet-Delivering Apparatus for Printing-Machines.  
No. 197,693. Patented Nov. 27, 1877.

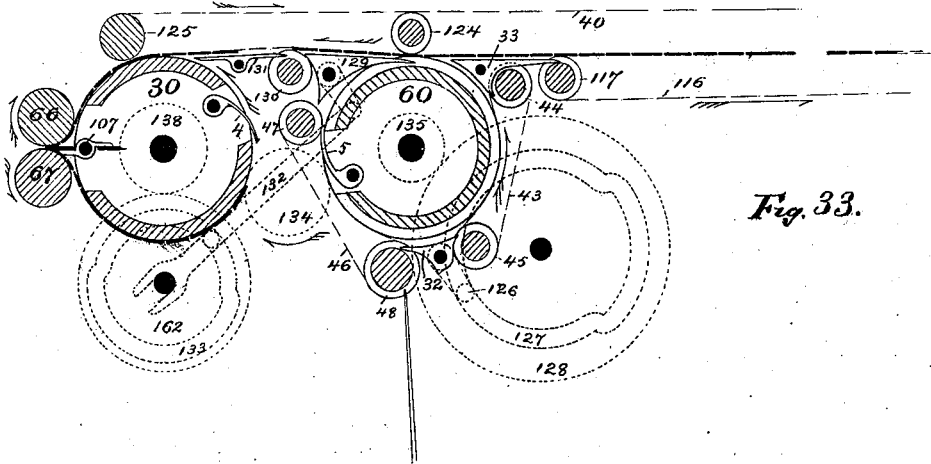

Fig. 33.

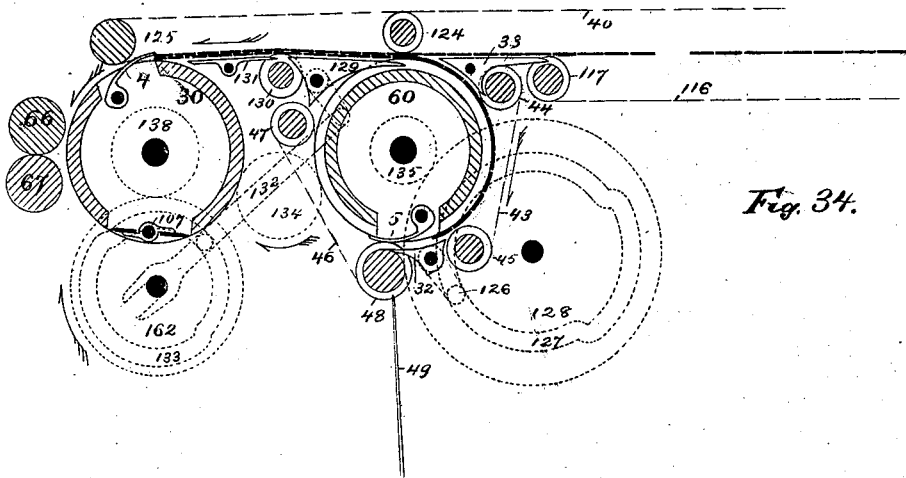

Fig. 34.

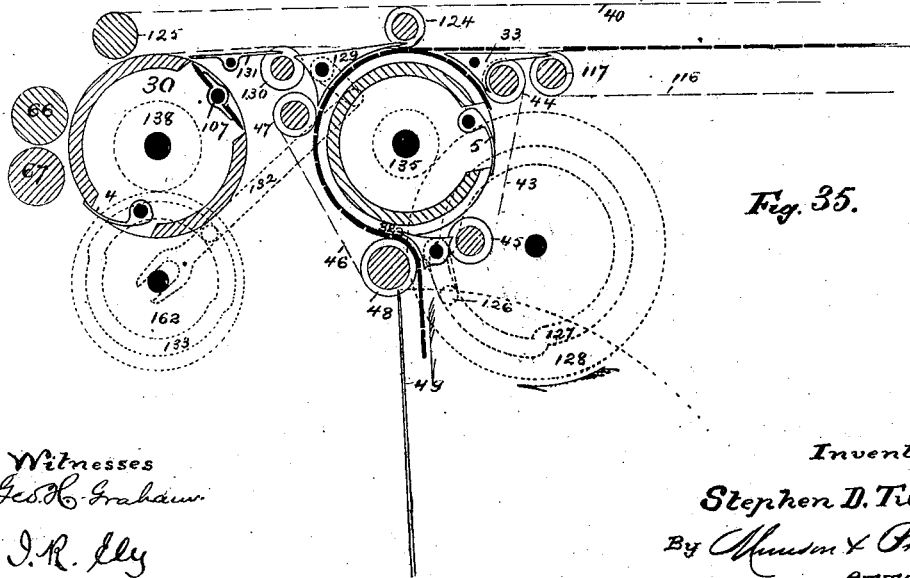

Fig. 35.

Witnesses  
Jes. H. Graham  
J. R. Ely

Inventor  
Stephen D. Tucker.  
By *Shuman & Philipp*  
ATTORNEYS

S. D. TUCKER.  
Sheet-Delivering Apparatus for Printing-Machines.  
No. 197,693. Patented Nov. 27, 1877.

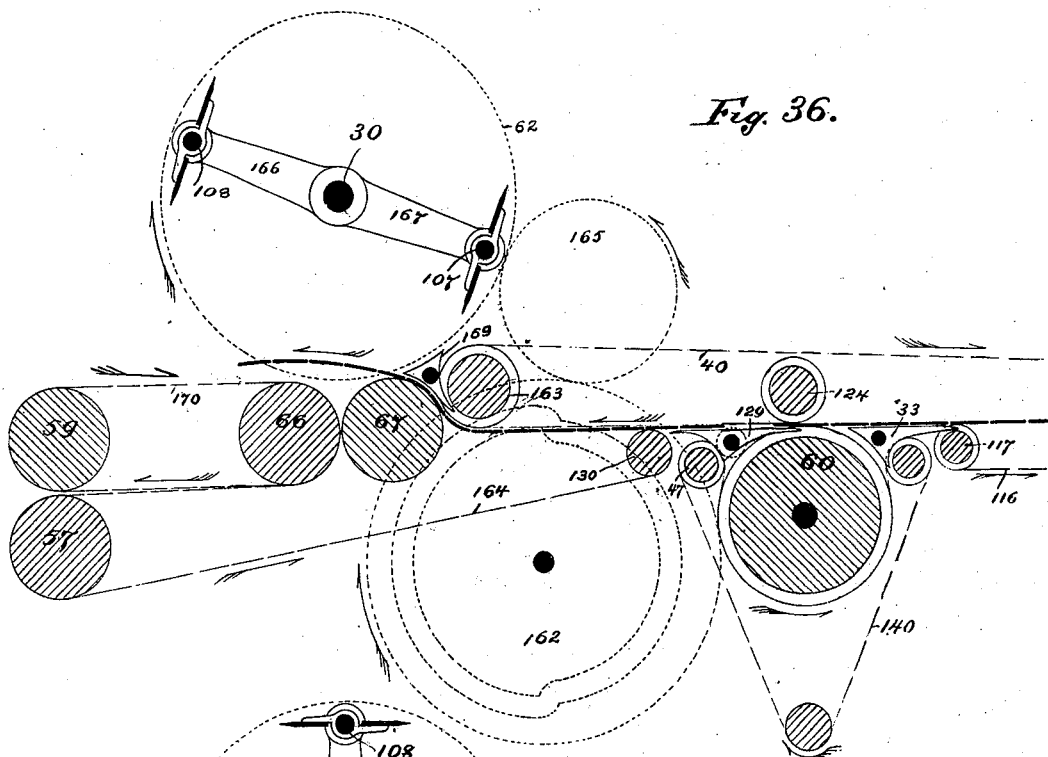

Fig. 36.

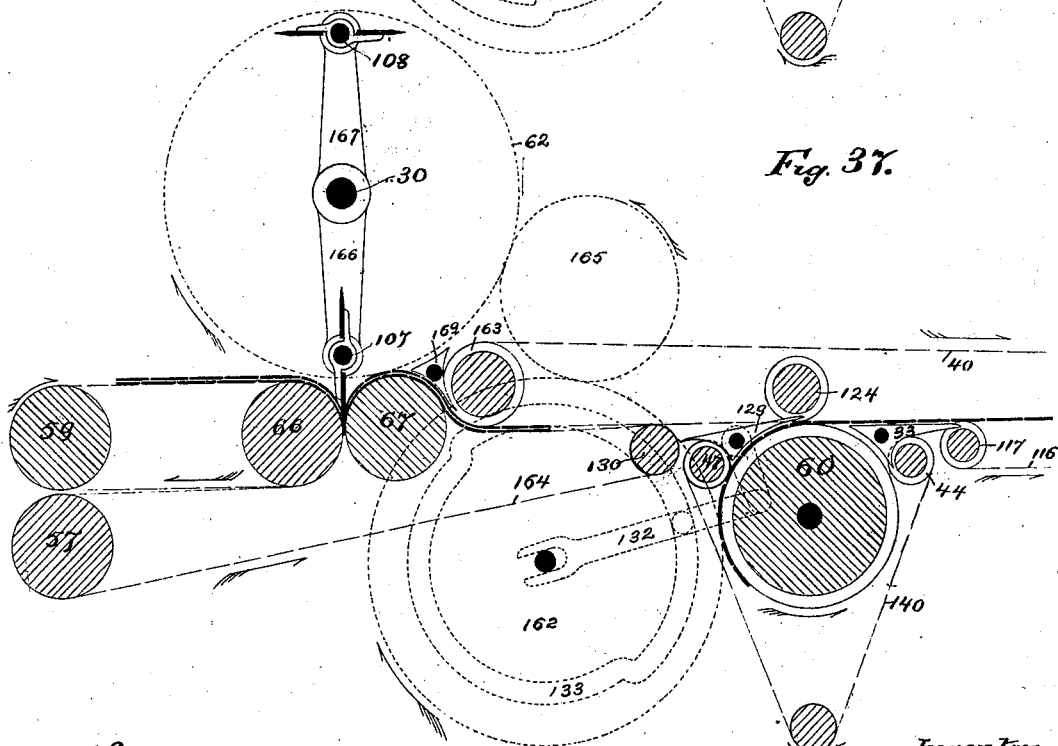

Fig. 37.

Witnesses  
L. H. Graham.  
J. R. Ely

Inventor  
Stephen D. Tucker  
By *Amos & Phelps,*  
ATTORNEYS

# UNITED STATES PATENT OFFICE.

STEPHEN D. TUCKER, OF NEW YORK, N. Y.

## IMPROVEMENT IN SHEET-DELIVERING APPARATUS FOR PRINTING-MACHINES.

Specification forming part of Letters Patent No. **197,693**, dated November 27, 1877; application filed November 6, 1877.

*To all whom it may concern:*

Be it known that I, STEPHEN D. TUCKER, of the city, county, and State of New York, have invented an Improvement in Delivery Mechanisms for Printing-Machines, of which the following is a specification:

In the drawings illustrating this invention, Figure 1 is a left-hand side elevation. Fig. 2 is a right-hand side elevation. Fig. 3 is a front-end elevation. Fig. 4 is a rear-end elevation. Fig. 5 is a plan, and Fig. 6 an elevation, illustrative of the sheet-lifting apparatus. Fig. 7 is an elevation of the folding and receiving rollers, and Fig. 8 a left-hand end view of the gearing driving the same. Fig. 9 is a view of a portion of the apparatus with the devices adjusted to perform the operation of gathering. Fig. 10 is a sectional view taken through the carriers 60 30. Figs. 11 and 12 are views of the griper-cams detached. Figs. 13, 14, 15, and 16 are diagrams showing the operation of the rotary folders. Figs. 17, 18, 19, and 20 are longitudinal sections, showing the mechanisms in different positions, and illustrating their action in the operation of folding both single and double sheets. Fig. 21 is a longitudinal section, showing a mode of attaching the apparatus to a "web-perfecting" printing-press, and providing it with a pasting apparatus. Fig. 22 shows a rear elevation of said pasting apparatus, taken on the line *a a* of Fig. 21, and a plan view of the driving-train; Figs. 23, 24, and 25, modifications wherein a vibrating switch and gripers are arranged to transfer the sheets from one cylinder to the other; Figs. 26, 27, and 28, a further modification, wherein the carriers 60 and 30 are of the same size, and arranged so as to deliver sheets direct from one to the other by means of gripers solely; Figs. 29, 30, 31, a further modification, wherein the carriers 60 30 are separated a distance apart, with a sheet-conducting mechanism interposed between them. Fig. 32 shows the switch 129 and pressure-roller 124 detached; Figs. 33, 34, 35, a further modification, wherein the separated carriers 60 30 are of the same size, and have a sheet-conducting mechanism interposed between them. Figs. 36 and 37 are longi-

tudinal sections, showing a modification of the carrier 30.

The invention relates to the delivery mechanism of printing-machines; and consists, essentially, in an apparatus provided with a mechanism for gathering or accumulating sheets, and with a mechanism for folding sheets, which mechanisms are so arranged and combined that the apparatus may operate, first, to accumulate any desired number of sheets and deliver the same flat as a single pack; second, to fold each successive sheet; third, to accumulate two or more successive sheets and fold the same one within the other as a single pack.

Various constructions and combinations of these accumulating and folding mechanisms, as well as devices auxiliary thereto, are embraced in the invention, as is also a mechanism whereby successive sheets are controlled, so that one may be stopped at one point and a second at another point over folding-rollers, and the two simultaneously doubled through the same by a folding-blade, all of which will be particularly hereinafter pointed out and distinctly claimed.

This apparatus, though it may be fed by hand, is designed to be connected with a printing-machine, its operation being to receive the sheets and dispose of the same as rapidly as they are printed and given off from the printing-machine, and to automatically deliver them in a flat or a folded condition, as may be desired. It is, however, especially adapted for operation with a web-perfecting printing-machine, being so organized as to be capable of great rapidity in its operation, thus having a capacity equal to that of such printing-machines as produce many thousand sheets per hour.

The mechanism illustrated for gathering or accumulating the sheets consists of a carrier and auxiliary devices for directing two or more sheets thereon and delivering the same in a single body therefrom, which carrier may also operate to receive and deliver sheets singly, as will be explained.

The mechanism illustrated for folding the sheets consists of a rotating carrier, which

supports one or more rotary folders, and has auxiliary means for conveying the sheets between said rotary folders and co-operating devices, and for actuating the rotary folders, as will be explained.

Both of these mechanisms may, however, be of different constructions, as will hereinafter appear.

The accumulating-carrier 60, of cylindrical form, as herein shown, is mounted in the frame-work at the entrance end of the apparatus, and is provided with a toothed wheel, 61, by which it is geared to a similar wheel, 62, fast on the shaft of the rotating carrier 30. Rotary motion is imparted to these carriers 60 30 by means of a toothed wheel, 63, made fast upon the shaft of the carrier 60, and geared with the toothed periphery of a cam-wheel, 64, which derives motion from a driving-pinion, 65. This carrier 60 is furnished with a set of tapes, 40, stretched over rollers 41 42 at its upper side, with a set of tapes, 43, stretched over rollers 44 45 at its front side, and with a set of tapes, 46, stretched over rollers 47 48 at its rear side, which tapes are driven by means of toothed wheels mounted on the shafts of said tape-rollers, and gearing with the toothed wheels 61. (See Figs. 1 and 2.)

The space between the rollers 45 48 constitutes one point of delivery of the sheets from this carrier, and is occupied by the switches 32, which are fast upon a shaft alternately rocked to move them into the positions shown in Figs. 9 and 10, their heels and toes playing in grooves in said rollers and carrier 60. Their operating mechanism consists of a rock-arm, 89, and a rod, 90, which is bifurcated to straddle the shaft 80, and carries a stud or friction-roller, entering the cam-groove 81 in the cam-wheel 64.

The space between the rollers 41 47 constitutes another point of delivery of the sheets from the carrier 60, where the grippers of the said carrier release the sheets and the grippers of the carrier 30 seize them, which operation will be hereinafter explained. This carrier 60 is also provided with a set of grippers, 5, fast upon a shaft hung in a recess running longitudinally therein and near its periphery, which grippers are held closed by a spring-seated rod, 88, connected with their rock-arm. They are operated at the proper time to receive the incoming sheets by means of a stationary cam, 31, fast to the frame-work, and at the proper point to release the same for delivery to the fly-frame 49 by the stationary cam 8, and they are also opened to release sheets for delivery to the grippers of the carrier 30 by the arm 26 of a rocking cam, 98, when the same is properly adjusted, as will be explained, which movements of said grippers are accomplished by means of a stud or friction-roller, 2, carried by their rock-arm, which, as the carrier 60 revolves, impinges against these cams 31 8 and cam-arm 26.

The point of entrance for the sheets to this carrier 60 is between the rollers 42 44, where

a guard, 33, is placed to aid in guiding them. In order that this carrier may perform the operation of accumulating many sheets, the rocking cam 98 is fixed in the position shown in Figs. 9 and 10, where its arm 26 is out of line of the path of travel of the stud or roller 2 on the rock-arm of the grippers 5. Said grippers will then be operated by the cams 31 8 only. This adjustment of the rocking cam 98 is effected by means of a screw, 9, which, protruded through a hole, 102, in the side frame, enters a hole, 160, Fig. 12, in said cam, which is dropped into its lowermost position to receive said screw.

With the mechanisms thus adjusted, this carrier 60 will operate to receive a sheet between its surface and that of the roller 42, where, being nipped by the tapes 40 and grippers 5, it will be drawn onto the surface of the carrier and travel around with it. The grippers 5 will be operated at the proper time by the cam 31, to open and seize the leading edge of the sheet thus entered upon the carrier, and, clamping it thereon, carry it around with said carrier. When one revolution of this carrier has been effected the grippers 5 will again be opened to receive the next incoming sheet, and closed to clamp its leading edge upon that of the first, and during the second revolution of the carrier the second sheet will be laid on the first upon the carrier, and the two thus accumulated. Though the grippers 5 are opened by the cams 8 and 31 during each revolution of the carrier, the sheets will be held securely thereon by means of the tapes 40 46 43 and guard 33, thus permitting the said grippers to open without disturbing the position of the sheets.

This operation may be repeated until three, four, or any other desired number of sheets are received and accumulated upon this carrier, which number (four in the present instance) is determined by the proportion of the toothed wheel 63 to the cam-wheel 64. When the predetermined number of sheets have thus been accumulated, the cam-groove 81 of the cam-wheel 64 will, through the rod 90, rock the toes of the switches 32 into the grooves of the carrier 60, as in Fig. 10, in which position they intercept the leading edges or heads of the sheets, which are released from the grippers 5 at this point by means of the cam 8, and guide the same in a single body off from said carrier, directing them over the roller 48, with which the front edges of the switches coincide, and down before the fly-frame 49, which may be vibrated by any common mechanism, to deliver the sheets in a single mass and flat upon a piling-table. When the tails of these sheets pass off from the carrier 60, the switches 32 will be automatically returned to the position shown in Fig. 9, and the operation repeated.

The carrier 30, as illustrated in Sheets 1 to 10, 12, and 14, is of twice the diameter of the accumulating-carrier 60, and is provided with two sets, 4 and 6, of grippers, whereby it is



adapted to carry two sheets upon its surface, and with two rotary folders, 107 108, each having, respectively, two folding-blades, 14 16 24 25.

The grippers 4 6 are mounted upon shafts set in recesses at opposite points in said carrier, and are held closed by means of spring-seated rods 50 51, fast to crank-arms which carry studs or rollers 52 53. These grippers are opened to receive the sheets by means of the arm 54 of the cam 98, with which the studs or rollers 52 53 of their crank-arms come into contact when said cam is in proper position, as in Sheets 1, 6, and 7, and these grippers are opened to release the sheets by contact of said studs or rollers with the stationary cam 55, Sheets 1 and 6.

The rotary folders 107 108 are hung upon shafts journaled in the heads of the carrier 30, occupying recesses cut at opposite points in said carrier, which shafts project beyond one head of the carrier, where they are provided with arms carrying studs or rollers 10 12 13 15. Said folders are caused to make semi-revolutions, and thus to alternately protrude the folding-blades 14 16 or 24 25 beyond the carrier, and between the folding-rollers 66 67, by means of flying-cams 17 18 and a stationary cam, 19. These flying-cams are upon a common shaft, which carries a toothed wheel, 20, meshing with a similar wheel, 21, fast upon the shaft of the rotating carrier 30, and they are thus constantly revolved in unison, and make equal turns with the carrier 30, but in a contrary direction. The stationary cam 19 is fastened to the side frame, as in Figs. 2 and 4, so as to co-operate with the flying-cams, as will presently appear.

The folding-rollers 66 67, which are placed at one side of this rotating carrier 30, are geared together by toothed wheels 136 137, fast to their right-hand ends, and are driven in unison with the carrier 30 by means of the toothed wheel 137, which meshes with the toothed wheel 62, which is fast upon the shaft of the carrier 30. (See Figs. 4, 7, and 8.)

Thus equipped, a sheet received upon this carrier 30, and clamped thereon by means of the grippers—say 4, as in Figs. 13, 14—will be laid upon its surface and carried around with said carrier. During a part rotation of this carrier, the center of the sheet will have been moved nearly in front of the folding-rollers 66 67, and the flying-cams 17 18 will have so far rotated in an opposite direction as to bring one of them—say 17—into proximity to the lower part of the female cam 19, in which position it will meet the stud or roller 10 on the forward arm of the rotary folders 107, and cause it to follow against the curved surface of said flying-cam 17 and that of the lower part of the stationary cam 19, as in Fig. 14. These movements proceeding, the flying-cam will form, in connection with the lower part of the stationary cam, a channel or way, which guides the roller 10 into the lowermost part of said stationary cam, thus rotating the folder 107,

and projecting one of its blades, as 14, beyond the periphery of the carrier 30, and between the folding-rollers 66 67, as in Fig. 15. The grippers 4 having, an instant before this projection of the blade, been caused to release their hold upon the sheet by contact of the stud or roller 52 on their rock-arm with the cam 55, (see Fig. 14,) the said sheet will be doubled between and nipped by the folding-rollers 66 67, and carried through them by their rotation as the carrier continues to revolve, during which movements the point of the flying-cam will pass the inner side of the stud or roller 10, and form, in conjunction with the upper portion of the stationary cam, a channel or way, which will guide the said stud or roller rearward, and cause it to move said folding-blade inwardly, as in Fig. 16, until it reaches its position within the recess in the carrier, where a spring, 82, holds it in place ready to be again actuated by the cams.

The carrier 30 will thus have made one-half of a revolution, and the grippers 6 will, in their turn, have received a sheet from the carrier 60, as in Fig. 16, which sheet, during the next half-revolution of the carrier 30, will be manipulated as was the former.

The sheets carried through the folding-rollers 66 67 emerge therefrom once folded, and may be carried by tapes or other conducting mechanism to a piling-table, or may be delivered to mechanisms for imparting to them one or more additional parallel or cross folds.

If these sheets are to be again folded it is preferable, in consequence of the high speed at which this apparatus is adapted to run, to convey the once-folded sheets to separate folding apparatuses.

One mode of effecting this is illustrated. It consists of two diverging conducting channels, 34 35, the exterior members of which are formed by plates 22 23, the former of which extends from the folding-roller 66 to the receiving-roller 56, and the latter from the folding-roller 61 to the receiving-roller 57, which plates may, if desired, have two entering grooves in said rollers. The interior members of these conducting-channels are formed by a switch, 36, consisting of two plates attached, at nearly right angles to each other, upon arms 38, fast upon a shaft, 39. This shaft is rocked by means of an arm, 68, and a connecting-rod, 69, which is bifurcated to straddle the shaft 80, and carries a stud or friction-roller, entering the groove 71 in the cam-wheel 64. This switch 36 will thus be moved so that its point is nearly in contact with one or the other of the folding-rollers 66 67, when it will conduct the sheets either to the lower or to the upper pairs of receiving-rollers 57 59 56 58. These receiving-rollers are provided with tapes 72 73, which run out over pairs of folding-rollers 74 141, through which, by means of a vibrating folding-blade, 75, a second fold at right angles to the first may be imparted to the sheets.

One such folding apparatus only is illus-

trated, the second, with which the upper tapes 72 73 connect, being its counterpart, and, located at a distance beyond the same, is not shown.

These receiving-rollers 57 59 are driven by means of a toothed wheel, 3, on the left-hand end of the shaft of the lower folding-roller 67, (see Figs. 1, 7, and 8,) which toothed wheel 3 gears, through an idler, 70, with a toothed wheel, 37, on the shaft of one of these receiving-rollers, said rollers being geared together by toothed wheels 76 77 on their right-hand end, so as to revolve in unison. The gearing is such as to reduce the speed of said receiving-rollers to about one-half that of the folding-rollers 66 67.

The folding-blade 75 is mounted upon a shaft, 83, to which motion is imparted by means of a rock-arm, 84, held in constant contact with a cam, 85, by means of a spring, 27. This cam 85 is fast upon a longitudinal shaft, 86, which latter is driven by bevel-wheels 78 79, the latter of which is fast upon the end of the main shaft 80, and the folding-blade 75 is thus caused to make one stroke to each second revolution of the rotating carrier 30.

The folding-rollers 74 141 are upon common shafts, geared together so as to run in unison, and driven by means of a toothed wheel, 11, carried by one of their shafts, and a train of gear-wheels, 159, connecting with a toothed wheel, 29, mounted on the shaft 86.

The shaft carrying one of each of these pairs of folding-rollers 74 141 is arranged so as to move toward and from the shaft carrying the companion rollers, and is acted upon by the springs 28. These folding-rollers are thus elastically seated, and thereby adapted to allow the passage of thickly-doubled-up or badly-folded sheets, whereby clogging or other ineffective operation is avoided.

Motion may be imparted to the receiving-rollers, to the vibrating folding-blade, and to the folding-rollers 74 141 by other means than is shown herein, and the means for actuating these mechanisms will be duplicated with respect to the receiving-rollers 56 58, and the mechanisms to which they conduct the sheets.

Any mechanism for connecting this apparatus with a printing-machine, whereby the product of the latter may be directed into it, may be employed. One such mechanism is shown in Fig. 21.

The cutting-cylinders 109 110 therein illustrated are supposed to be at the delivery end of a "web-perfecting" printing-machine, and they are geared together, and also to one of the driving toothed wheels of the printing-machine. Motion is imparted to the carrier 60 by a train of gear-wheels 119 120 121 from the toothed wheel 115 on the cutting-cylinder 110. By this arrangement of gearing the carrier 60, cutting-cylinders 109 110, and the printing-cylinders (not shown) are caused to run turn for turn with each other.

The roller 42 is removed and the tapes 40 are extended to run over rollers 111, situated

near the cutting-cylinders. A fourth set of tapes, 116, are also stretched from a roller, 117, situated at the rear of the roller 44, to a roller, 112, situated below the roller 111. These tapes are run in unison by means of gear-wheels which connect the rollers 111 112 together, and are driven by the roller 41, which is geared to the toothed wheel 61, as before described. They serve to receive the sheets from the cutting-cylinders and to conduct the same to the grippers of the carrier 60. The cutter 118 will generally be arranged to partially sever the web, though it may completely divide it; and as the carrier 60 is somewhat larger than the cutting-cylinders, it follows that when the end of the web is seized by the grippers and the nip of the tapes 40 on the carrier 60, its speed will be accelerated, whereby the web will be separated at the line of partial severance to form a sheet, which sheet (or one formed by the complete cutting of the web by the cylinders 109 110) will be carried onward rapidly enough to separate its rear end from the forward end of the web or succeeding sheet, as at 158. Thus sheets delivered to the carrier 60 will be separated a distance apart, which provides a space between the heads and tails of the sheets, which space between such as are accumulated upon the carrier 60 is occupied by the grippers 5, and provides for the operation of the switches 32. This space caused by the separation of the sheets also provides for the perfect operation of the grippers of the carrier 30.

When two sheets are to be associated together, as already described, they may, if desired, be caused to adhere to each other by giving to one of them a longitudinal or a transverse line of paste, by means of the apparatus shown in the Patent No. 191,494, granted to S. D. Tucker, May 29, 1877.

One such pasting apparatus is illustrated in Figs. 21, 22, and consists of a revolving paste-blade, 172, that alternately comes in contact with a slow-running roller, 173, in the paste-fountain 177, to receive a charge of paste, and with, say, the center margin of a fast-running sheet, to which the paste is applied, and the motion of the paste-blade should coincide with the speed of each of these while in contact with them. To effect this the paste-blade shaft 175, to which the blade is attached by means of the arms 178, is driven by the well-known differential movement in which the axis of the driver, which, in this case, is the wheel 139, is placed parallel with, but eccentrically to, the axis of the driver, which is the paste-blade 172. As paste is to be applied only to the alternate sheets, the paste-blade need make but one revolution to each second sheet that passes; and this is effected as follows: The train of wheels 115 119 120 121, which connect the cutting-cylinders with the carrier 60, are all of the same size as the carrier, and run turn for turn with it, and, of course, their peripheries travel at the same speed as the periphery of the carrier, and the

sheet which it grasps. The wheel 120 is fixed on the shaft 180; and just outside of this wheel, but with a certain space between them, is fixed on said shaft another wheel, 114, of the same size. This wheel 114 gears into and drives the wheel 139, which is of twice its size, whereby the periphery of this wheel 139 will also travel at the same speed as the sheets. This wheel 139, which will make but one revolution to each second sheet that passes, has fixed in it a crank-pin, 176, just half-way between its periphery and its center, and which will thus travel at but half the speed of the sheets. This crank-pin works in a slotted lever, 174, secured to the outer end of the paste-blade shaft 175, in the space between the two wheels 114 120, and when the crank-pin is passing its lowermost point it will be in contact with the slotted lever, at a distance just half-way between the center of the shaft 175 and the outer edge of the pasting-blade. This will cause the edge of the pasting-blade to travel at that time at twice the speed of the crank-pin—that is, at the same speed as the sheet with which it is at that time in contact and operating to apply its line of paste. As the wheel 139 continues to revolve and brings the paste-blade around under the paste-supplying roller 173, the crank-pin 176 will, on account of the eccentricity of their axes, run out to the extreme outer end of the slotted lever 174, and thus cause the paste-blade to move at a very slow speed at that point. The paste-blade is thus brought into contact with and receives a charge of paste from the paste-roller 173, and during this time a second sheet will have passed by the pasting apparatus. The paste-roller may be driven in any common manner, but must move at the same speed as the paste-blade while the two are in contact. The paper, while being pasted, is supported by a roller, 170, having a longitudinal groove in its surface. The roller is shown in this case as being just one-fourth the size of the wheel 121, which drives it, and the paste-blade will thus always strike over the groove, so that when, from any cause, there is no sheet upon it to receive the paste, the roller will not be smeared. The paste-blade is cut away, as at 179, so as to span the tapes 40 116, and thus neither apply paste to them nor cut them. The tapes 40, after passing over the roller 41, run up over the roller 171, and so on to the roller 111, and thus entirely escape the pasting apparatus. The first sheet, receiving its line of paste, will be carried around upon the surface of the carrier 60, and will receive the second or unpasted sheet upon it, which two sheets, thus associated together, (in manner heretofore explained,) may be delivered to the carrier 30 to be folded, as in Figs. 19, 20, 27, 28, 30, 34, and 37, or one or more pairs of sheets thus pasted and associated may be delivered flat from the accumulating-carrier 60 by the switches 32 and fly-frame 49, as in Figs. 10, 31, and 35.

To adapt the apparatus so that it will fold

each successive sheet received from the printing-machine, or otherwise delivered to the grippers of the carrier 60, the cam 98 is fixed in its highest position, as shown in Sheet 7, by inserting its holding-screw 9 through a hole in the side frame, which is above that marked 102, (see Fig. 1,) when its arm 54 will open the grippers 4 and 6 as their rock-arms come in contact with it, and its arm 26 will in like manner operate the grippers 5.

In order that this operation of the apparatus may be clearly understood, the sheets illustrated as undergoing manipulation are alternately marked A and B. Each sheet received is directed by the tapes onto the carrier 60, where its leading edge will be seized as it enters upon the same by the grippers 5, operated by the cam 31, to open and receive the leading end of the sheet, as in Fig. 13, and closed to clamp the same upon said carrier, as in Fig. 18. Thus seized and held by the grippers, the sheets will be caused to travel around with the carrier until a point is reached between the rollers 41 47 where said carrier is nearest in contact with the carrier 30, when the grippers 4 of the carrier 30, which have been opened as they move into position to intercept the leading edge of the sheet, as in Fig. 18, by means of the arm 54 of the cam 98, with which the stud or roller 52 on the rock-arm of said grippers engages, will close and seize the edge of the sheet as the stud or roller 52 passes off said cam-arm 54, as in Fig. 17. This is accomplished an instant before the stud or roller 2 on the shaft rock-arm of the grippers 5 comes into contact with the arm 26 of the cam 98, as in Fig. 18, and is thereby operated to open said grippers and release the said sheet, as in Fig. 17. The carrier 60 thus operates simply as a means for conveying the sheets it receives to the carrier 30. The sheets thus transferred from the grippers 5 of the carrier 60 to the grippers 4 of the carrier 30 will be carried around thereby as the rotation of both carriers proceeds.

The sheet A thus held will be laid on the surface of the carrier 30, so as to cover the rotary folder 107, as in Figs. 13, 18, and will be carried onward with said carrier. As the center of the sheet approaches the point occupied by the folding-rollers 66 67, the stud or roller 10 on the forward arm of the rotary folder will come into contact with the front side of the flying-cam 17, which is moving in concert with the carrier 30, and be thereby carried to follow the surface of the lower half of the stationary cam 19, whereby the folding-blade 14, rocking with its shaft, will be moved outward from the carrier, and entered between the folding-rollers 66 67, carrying with it the sheet A, which will thereby be doubled into said rollers, which will nip its doubled edge, as in Fig. 15. An instant before this movement of the folding-blade is commenced, the stud or roller 52 on the rock-arm of the grippers 4 will, engaging with the cam 55, open said grippers and release the leading

edge of the sheet. The point of the flying-cam 17 then passes over the stud 10 on the arm of the folding-blade, and, by means of its rear side and the upper surface of the stationary cam 19, will guide the folding-blade 14 inward to its former, but reversed, position in the recess in the cylinder, (see Fig. 17,) where it remains until again operated by the flying and stationary cams.

The next sheet, B, entered upon the carrier 60, will be seized by its grippers 5, as in Fig. 18, delivered to the grippers 6 of the carrier 30, be thereby carried around with said carrier, and doubled into the nip of the folding-rollers 66 67 by the blade 25 of the rotary folder 108, in like manner as was the preceding sheet, A.

It will be observed that the rotary folders 107 108 are each made double—that is, provided with two folding-blades; and hence, when one blade, as 14 or 24, makes a half-revolution in the operation of folding, its companion, as 16 or 25, is brought into the foremost position, and will be the next of its pair to be projected in the folding operation; also, that one, 17, of the flying-cams always operates the blades 14 and 16 of the rotary folder 107, and the other flying-cam, 18, always operates the blades 24 and 25 of the rotary folder 108.

This construction is a desirable one; but the number of rotary folders and flying-cams, and the means for and mode of their operation may be varied, as will hereinafter appear.

The sheets, emerging from the folding-rollers 66 67, will be directed by the conducting-channels 34 35 to the upper set of receiving-rollers 56 58, or to the lower set 57 59, according as the switch 36 may be moved into position with the lower folding-roller 67 or the upper folding-roller 66.

As the rotating carrier 30 and the rotary folders it carries are adapted to run at high speed, it is necessary, when the sheets folded thereby through the rollers 66 67 are to be further manipulated by vibrating folders, that they shall be conducted to two such mechanisms, or to such other number of vibrating folders as shall have a capacity equal to the manipulation of the number of sheets which said carrier 30, its rotary folders, and co-operating devices will produce.

The machine illustrated provides for the folding of four sheets by such vibrating folding-blades, two only of which are shown—namely, those to which the receiving-rollers 57 59 conduct the sheets—it being understood, as before explained, that the receiving-rollers 56 58 conduct the alternate two sheets to a similar folding mechanism.

The switch 36 is vibrated once during each revolution of the carrier 30, and, having been moved into the position shown in Fig. 17 to direct two successive sheets B A to the receiving-rollers 57 59, will be moved into the position shown in Fig. 18, to direct the succeeding pair of sheets B A to the delivering-

rollers 56 58, then, returning to the position, Fig. 17, will direct the following pair to the rollers 57 59, and so on.

In the arrangement shown, where two successive sheets, B A, are to be directed on over two sets of folding-rollers, as 74 141, and simultaneously folded through the same by a single folding-blade, as 75, it is necessary to provide independent stops which shall register the foremost sheet over the folding-rollers 74, and the rearmost sheet over the folding-rollers 141.

In order that the movement of the sheet B, which is to be folded through the folding-rollers 74, may not be impeded by the stop 97, which arrests the sheet A in register over the folding-rollers 141, an uninterrupted path of travel for the sheet B to the said folding-rollers 74 must be provided. This is done, as is shown in Figs. 1, 2, 5, 6, and 17, by means of a lifting-rod, 91, (which will preferably carry a roller,) hung in arms 92, fast on a shaft which is rocked by means of an arm, 93, and a connecting-rod, 94, which is reciprocated at proper intervals by a cam, 95, fixed on the shaft 80, and which cam thus makes one revolution to every four sheets received on the carrier 60. As the leading sheet B of the pair conducted through the channel 35 is emerging from the rollers 57 59, the lifting-rod 91 is caused to rise and elevate the tapes 72 73 to a position above the stop 97, thus providing an uninterrupted path of travel for the sheet to its position against the stop 96 and over the folding-roller 74, as in Fig. 17. When the tail of this sheet B has passed the stop 97, the lifting-rod 91 is dropped, so as to lower the tapes into the position shown in Fig. 18, whereby the second sheet A will be directed against the stop 97 over the folding-rollers 141.

As the once-folded sheets emerge from between the folding-rollers 66 67, they occupy but half the space in the direction of their line of travel that they did before being folded, and consequently there will be a great space between them. The first sheet, B, of the pair will, upon being nipped between the receiving-rollers 59 57, take up their reduced motion, and thus travel more slowly than while passing between the folding-rollers 66 67. This movement of it will be such that it will have passed nearly through the rollers 59 57 when the head of the next sheet A is emerging from the folding-rollers 66 67, and the two will thus be separated a considerable distance apart; but as sheet B continues to be moved slowly by the action of the rollers 59 57, while the sheet A is moved rapidly by the rollers 66 67, it follows that the sheet A will gain on the sheet B, so that when the former reaches the rollers 59 57 and takes their speed of travel, the said sheets will be separated no farther apart than is necessary to permit the proper action of the devices in delivering the sheet B over the rollers 74 and the sheet A over the rollers 141, and register them against their

respective stops 96 97 at about the same instant. The two sheets B A will thus be independently adjusted over the folding-rollers 74 141, through which they may be simultaneously folded by the folding-blade 75, as in Fig. 18. Thus the sheets from the printing-machine will be received by the grippers of the carrier 60, seized thereby, and delivered to the grippers of the carrier 30, carried thereby into proper position before the folding-rollers 66 67, folded by the folding devices of the carrier 30 into the nip of these folding-rollers, and delivered therefrom in a once-folded condition; and if the devices for their subsequent manipulation are such as shown, said folded sheets will be conducted two by two alternately to separate vibrating folding devices, and be a second time folded on lines at right angles to their first fold.

In delivering mechanisms for printing-machines which impart folds to the sheets, it is a desideratum to fold two or more sheets one within the other, in order that sheets constituting the outside and inside pages of a complete newspaper or book signature shall be associated before their primary fold is made.

This apparatus may have its mechanisms so adjusted that the carrier 60 will accumulate two or more sheets before delivering the same to the grippers of the carrier 30.

To accomplish this the cam 98, which, in the last-described adjustment and operation of the apparatus was fixed in the stationary position shown in Sheets 1, 6, and 7 by the set-screw 9, is released, so as to be capable of rocking on its shaft 7, and a rock-arm, 99, fast on said shaft 7, is attached to a rod, 100, which is operated by an eccentric, 101, on the shaft of the carrier 30, as in Figs. 19, 20. The cam 98 is thus caused to rock at each revolution of the carrier 30, thus moving its arms 54 26 alternately into the position shown in said Figs. 19, 20. In the latter the arm 54 is in the position where it intercepts and operates the rock-arms of the grippers 4 and 6, and the arm 26 is in the position where it intercepts and operates the rock-arm of grippers 5, while in Fig. 19 the said arms are shown as rocked into the position where they are out of the path of travel of the rock-arms of said grippers.

Thus arranged, the grippers 5 of the carrier 60 will seize the first incoming sheet and carry the same on its surface around with it, as in Fig. 19, and as the arms 26 54 of the cam 98 will, during this revolution of the carrier 60, have been rocked into the position therein shown, the said grippers 5 will not be opened to deliver this sheet to the grippers of the carrier 30, neither will these latter be opened to receive it, but it will be carried around with the carrier 60 until the grippers 5 are opened by the cam 31 at the proper time to receive the second incoming sheet, which, overlying the first, (now held upon the carrier 60 by the tapes 43 46 40,) will be seized by said grippers, and the two sheets will be carried onward by

them, as was the first sheet. The two sheets, thus laid one upon the other, will have their leading edges released by the grippers 5 and delivered to the grippers 6, as has been described with reference to the manipulation of single sheets, the cam 98 having, during the second revolution of the carrier 60, been rocked so as to bring the arms 54 26 into the position shown in Fig. 20 to operate these grippers. The two sheets thus associated and held by the grippers 6 of the carrier 30 are carried around with it, released by the grippers, folded together through the folding-rollers 66 67 by the rotary folder 108, and delivered by said rollers out of the machine in a once-folded condition, or to the auxiliary folding devices, to be again folded, in manner similar to that described with reference to single sheets. In thus manipulating the sheets by this apparatus, adjusted as in Figs. 19, 20, it is to be observed that one set of grippers, 4, are inoperative, and that one rotary folder, 107, operates idly.

Three or even a greater number of sheets may be thus accumulated upon the carrier 60, and delivered simultaneously to the carrier 30, to be folded together by providing the apparatus with a mechanism which will reciprocate the rod 100 once to each three or more revolutions of the carrier 60.

The lifting-rod 91 may be rendered inactive during this operation, if desired, by securing it in its lowest position by means of a screw protruding through a hole, 103, in the side frame, and entering a hole, 104, in the connecting-rod 94, and the switches 32 may be thrown out of action by disconnecting their actuating-rod 90 from the rock-arm 89.

When the apparatus is arranged to deliver the sheets flat, by means of the accumulating-carrier, the vibrating folding mechanism may be thrown out of action, if desired, by loosening the screw 105, which fastens the shaft 86 to the coupling 106, and sliding said shaft endwise; and by sliding the wheel 61 on the shaft of the carrier 60 endwise out of gear with the wheel 62, which drives the carrier 30, this latter will stand idly during the time when the apparatus is adjusted to accumulate the sheets for flat delivery.

While it is desirable to provide the accumulating-carrier 60 with grippers, in order to secure great accuracy in the manipulation of the sheets, said grippers may be dispensed with, as in the modifications, Sheets 10, 12, 14.

In the modification, Sheet 10, the carrier 30 is provided with rotary folders 107 108 and grippers 4 6, as before, and the carrier 60 has the guard 33 and tapes 40 116 arranged as in Fig. 23, and is also supplied with a set of tapes, 140, stretched from the roller 44 to the roller 47, thus extending over about one-half of the periphery of said carrier. Guards 87 are fixed so as to protrude beyond the roller 41 nearly to the point of contact of the carriers 60 30, and a switch, 142, hung on a shaft between the said carriers, is arranged to be

rocked from the position shown in Fig. 23 to that shown in Fig. 24 by means of a rock-arm, whose stud or roller, 143, runs in a cam-groove, 144, of a cam-wheel fixed upon the shaft of the carrier 30. This rock-arm is fast upon a shaft, 145, journaled in the frame-work, and carrying a rock-arm, 146, which is connected by a rod, 147, with a rock-arm, 148, fixed to the shaft of said switches 142, as in Fig. 24. This shaft 145 also carries a rock-arm, 149, which supports at its end a cam, 150, which is arranged to intercept the rock-arms 52 53 of the grippers 4 6, and thus open said grippers to receive the sheets, and close the same to clamp the sheets upon the carrier 30. As the cam-groove 144 is arranged so as to hold the switches 142 and cam 150 in the positions shown in Fig. 24 during one half of its rotation, and during the other half of its rotation to sustain said devices in the positions shown in Fig. 25, and as the carrier 60 makes two revolutions to one of the carrier 30, it follows that the first sheet received by the carrier 60 will be guided around the same by means of the switches 142, which stand with their toes entering grooves in the carrier 30, and with their inner sides coinciding with the periphery of said carrier 60, as in Fig. 24. When the head of the sheet thus carried around the carrier 60 reaches the entrance-point, a second sheet will be received on the first, upon the carrier, and travel with it. At this time the carrier 30 will have so far rotated as to cause the cam-groove 144 to rock the switches 142 and the cam 150 into the positions shown in Fig. 25, where the toes of the switches will have entered the grooves in the carrier 60, so as to intercept the sheets and guide the same onto the carrier 30. This movement also brings the cam 150 into position to intercept the rock-arm of the grippers 6, and cause them to open to receive the heads of the said two sheets, close, and clamp the same onto the carrier 30, and convey them between the rotary folder 108 and folding-rollers 66 67, to be folded and delivered, as hereinbefore described. The next succeeding two sheets associated together by the accumulating-carrier 60 will be delivered to the carrier 30 by the switches 142, seized by the said grippers 6, and folded in like manner as were the first two sheets, the grippers 4 being inoperative, and the rotary folder 107 operating idly, as hereinbefore described.

This modified form of the apparatus may be adapted to fold each successive sheet by removing the rock-arm, so that its stud 143 shall no longer engage with the cam-groove 144, and securing the cam 150 and switches 142 fixedly in the positions shown in Fig. 23. By this arrangement each sheet received upon the carrier 60 will be directed by the switches onto the carrier 30, and the grippers 4 6 will be operated by the cam 150, to seize alternate sheets and carry the same into position to be folded and delivered between the rollers 66 67. The carrier 60 may, if desired, be ar-

ranged so that it will accumulate many sheets, and deliver the same flat, by supplying it with tapes 43 46 and switches 32, as hereinbefore described. In such an arrangement the switches 142 must be fixed in the position shown in Fig. 24.

It is apparent that the carrier 30 may be of the same size as the carrier 60, and be supplied with but one set of grippers as 4, and one rotary folder, as 107, (see Sheets 11, 13,) and thus make one idle revolution when two sheets are being associated by the accumulating-carrier 60, while the said carrier 30, when it is of double the size of the carrier 60, makes a half-revolution idly during such operation of the accumulating-carrier 60, as hereinbefore described.

Sheet 11 shows a modification of this apparatus, wherein the two carriers of equal size are geared together, so as to run in unison, each being provided with grippers. It further shows these carriers running in an opposite direction to the movements they are shown to have in the preceding illustrations, the sheets being received at the lower side of the carrier 60 from the tapes 116 40. The grippers 4 5 in this arrangement are operated by cams 151 152, carried at the ends of arms which are fast upon separate shafts, which shafts are connected together, so as to move in unison, by arms 153, whose ends have segment-racks. Motion is imparted to one of these shafts, and communicated to the other by the arms 153, from a rock-arm, 154, whose stud or friction-roller enters a cam-groove, 155, in a toothed cam-wheel, 156, which meshes with a toothed wheel, 157, fast upon the shaft of the carrier 30. The gearing is such that this cam-wheel makes but one revolution to each two of the carrier 30, and its cam-groove 155 is of such shape that it rocks the cams 151 152, so that they stand in the positions shown in Fig. 27, when they will not operate the grippers 4 5 during the first revolution of the carriers 30 60, and into the position shown in Fig. 28, when they will intercept the rock-arms of and operate the said grippers during the second revolution of the said carriers.

The first incoming sheet received by the carrier 60 will be seized by the grippers 5, which are always operated for this purpose at the entrance-point of the sheet by a stationary cam, such as 31, Sheet 5, and carried around with and upon the surface of the carrier 60, as in Fig. 27, the cams 151 152 then standing in the positions therein shown, until its head or leading edge arrives at the entrance-point, where the second incoming sheet will be received upon it, and the two seized by the grippers 5, and carried together around with the carrier 60, in manner hereinbefore explained. The cams 151 152, having meanwhile been moved by the cam-groove 155 into the positions shown in Fig. 28, will intercept the rock-arms of the grippers 5 and open said grippers to deliver two sheets to the grippers 4, which will close upon and convey the same between the



folding devices to be folded thereby and delivered through the folding-rollers 66 67.

It is to be understood that the grippers 4 are operated to seize the sheets an instant before the grippers 5 release the same, as in Fig. 26; also, that only one flying-cam, as 17, is required, in connection with the stationary cam 19, to operate the rotary folder 107.

If it is desired to fold each successive sheet, the cams 151 152 are fixed in the positions shown in Fig. 26, where they will operate the grippers 4 5 during each revolution of the carriers. This may be done by simply sliding the toothed wheel 157 out of gear with the cam-wheel 156, which latter then, being stationary, will hold the cams 151 152 in either position, according as it is placed.

Though it is advantageous to set the carriers 60 30 in such relation to each other that they may deliver the sheets directly from one to the other, as in Sheets 1 to 11, they may be separated a distance apart, as is shown in the modifications illustrated in Sheets 12, 13, 14, where they are provided with intermediate mechanisms for conducting the sheets from one to the other.

In the modifications, Sheets 12, 13, the tapes 40 pass under a pressure-roller, 124, by which they are held in contact with the carrier 60, and extend over a roller, 125, resting on the upper side of the carrier 30. These tapes, together with tapes 116, connect with the printing-machine, as in Fig. 21.

As the carrier 60 in the modifications, Sheet 12, has no grippers or tapes to nip the sheet at its entrance on it, and thus complete its severance from the partially-cut web, this function is performed by the pressure-roller 124, which is geared to and driven by the carrier 60, so as to run in unison with it. It is mounted in elastic bearings, as shown in Fig. 32, so that its pressure is a yielding one, accommodating the sheets as they accumulate on the carrier.

The tapes 43 are arranged as in Fig. 21, and the roller 47 is arranged so as to stretch the tapes 46 over a greater portion of the surface of the carrier 60, and the switches 32 are arranged so as to be rocked at proper intervals by means of a rock-arm, whose stud or roller 126 runs in the cam-groove 127 of a cam-wheel 128, which may be on the driving-shaft, and imparts motion, through a toothed wheel, 135, to the carrier 60, which in turn drives the carrier 30, through a toothed wheel, 134. The driving-roller 130 is driven positively from the carrier 60 by a toothed wheel, 122, which gears through a wheel, 161, to the toothed wheel 61 on the shaft of said carrier, as in Fig. 32.

A switch, 129, covers a portion of the periphery of the carrier 60, and occupies the space between said carrier and the driving-roller 130, while a conductor, 131, bridges the space between the roller 130 and the carrier 30; and this conductor 131, roller 130, and switch 129, together with the tapes 40, consti-

tute the mechanism connecting the carriers 60 30.

The carrier 30, which is of double the size of the carrier 60, is equipped with grippers 4 6 and rotary folders 107 108, and mechanisms for operating the same, as in the preceding illustrations.

The switches 129 are rocked from the position shown in Fig. 29, where their toes lie in grooves in the carrier 60, to the position shown in Figs. 30, 31, where their heels and toes enter grooves in the rollers 124, 130 by means of a rock-arm and connecting-rod, 132, which latter is operated by a stud or roller, which, projecting from its side, enters a cam-groove, 133, in a cam-wheel fixed upon the shaft of the rotating carrier 30, as in Fig. 30.

The cam-groove 133 is arranged to move the switch 129 during each revolution of the carrier 30, and as the carrier 60 makes two revolutions to one of the carrier 30, and as the motion imparted by the cam-groove 133 is equally divided, it follows that the switches 129 will stand in the position shown in Fig. 30 during the first revolution of the carrier 60, and in the position shown in Fig. 29 during the second revolution of said carrier. Thus arranged, the first incoming sheet will be directed by the switches 129 around the carrier 60, it being propelled and sustained by the roller 124, tapes 46 43, and guided by the conductors 33 and switches 129, as in Fig. 30. As the head of this sheet reaches the point where it entered upon the carrier, it will be met by the second incoming sheet, whose leading end will be lapped upon that of the first sheet, and the two thus move together; and as the toes of the switches 129 are, as soon as the tail of the first sheet is past them, rocked into the position shown in Fig. 29, the said two sheets thus associated will be directed over the top of said switches, and carried by the tapes 41 and propelling-roller 130 onto the carrier 30, when the leading edges will be seized, and the sheets folded in like manner as are the two associated sheets by the mechanism illustrated particularly in Sheet 8.

If it is desired to adjust this mechanism so as to fold each sheet, the switches 129 may be fixed into the position shown in Fig. 29, after the cam-operated connecting-rod 132 has been disconnected from their rock-arm. This done, each sheet will pass over the carrier 60, and be led directly to the carrier 30, and be folded in like manner as by the mechanisms particularly illustrated in Sheet 7.

Again, if it is desired to gather and deliver flat two or more sheets, it may be done by fixing the switches 129 in the position shown in Fig. 31. Thus arranged, sheet after sheet will be directed onto the carrier 60, until several are accumulated one upon the other, the predetermined number here illustrated being four, when the toes of the switches 32 will be rocked into the grooves in the carrier 60, thus intercepting the accumulated sheets, and directing

the same in a single mass over the roller 48, and down before the fly-frame 49, as hereinbefore described. In this adjustment of the machine the connecting-rod 132 may be removed or allowed to stand in the position shown in Fig. 31, where it is rendered inoperative, as is the carrier 30, by removing the toothed wheel 134, or sliding it out of gear with the toothed wheel which drives said carrier 30.

The modification, Sheet 13, besides having the two carriers 30 60 of equal size, and each provided with one set of grippers, and the carrier 60 provided with one rotary folder, as in Sheet 11, differs somewhat in its gearing from the modification, Sheet 12. Thus the cam-wheel 162, which operates the switches 129, is set upon an independent shaft, and driven by a toothed wheel, 138, on the shaft of the carrier 30. It makes one revolution to every two of the accumulating-carrier 60, and thus holds the switches 129 in the position shown in Fig. 35 during the first revolution of the carrier 60, and thus guides the first sheet around with said carrier, and as the second sheet is received on the first upon said carrier during its second revolution, it will have moved the switches into the position shown in Fig. 34, to intercept the same, and guide them over its upper surface to the carrier 30, where their leading edges will be seized by the grippers 4, and the two carried together between the folding devices of the said carrier, and be thereby delivered once folded between the folding-rollers 66 67, in manner as before explained. If it is desired to fold each successive sheet by this modified apparatus, or to accumulate a number of sheets for flat delivery, the switches 129 may be fixed in the position shown in Fig. 33, or in that shown in Fig. 35, by sliding the toothed wheel 138 out of gear with the cam-wheel 162, as heretofore described.

When either of the modified apparatuses shown in Sheets 12, 13 is adjusted to fold the sheets, the switches 32, constituting a part of the accumulating mechanism, may be thrown out of action by disengaging the stud 126 or its rock-arm from the cam-groove 127.

In the modification, Sheet 14, the accumulating-carrier 60 is separated a distance from the carrier 30, which space is occupied by a connecting mechanism composed of the tapes 40 164 and switches 129. The tapes 40 run over a roller, 163, placed near one of the folding-rollers 66 67, which are arranged beneath the carrier 30. The tapes 164 are stretched from the driving-roller 130 over folding-roller 67, under folding-roller 66, and around the receiving-roller 57. The switches 129 bridge the space between the carrier 60 and the driving-roller 130, as in Sheets 12, 13, and are operated, as therein shown, by the cam-groove 133 of the cam-wheel 162. The set of tapes 140 are stretched from the roller 44 to the roller 47, as in said Sheets 12, 13; but the roller 47 is raised to such a position as will cause these

tapes to cover the greater portion of the periphery of the carrier 60.

In this modification, motion is communicated from the carrier 60, through a toothed wheel, 162, and an intermediate wheel, 165, to the toothed wheel 62 of the carrier 30. This carrier 30 is illustrated as constructed of two arms, 166 167, which support at their ends the rotary folders 107 108. A guard, 169, is placed between the tape-roller 163 and folding-roller 67, to insure the proper guidance of the sheets over the folding-rollers 66 67, and into proper position to be doubled through them by the rotary folders, which folders are operated by a flying-cam and a stationary cam, as hereinbefore described. A set of tapes, 170, stretched from the folding-roller 66 to the receiving-roller 59, support the leading ends of the sheets as they pass out over the folding-rollers, and, with the tapes 164, direct the sheets, after they are folded, through said rollers, to the receiving-rollers 57 59, from whence they may be directed to a delivery mechanism or to a folding mechanism, as hereinbefore described. The sheets may be folded singly, as in Fig. 36, or accumulated in twos, which are simultaneously folded, as in Fig. 37, by properly operating the switches 129, which may be done, as hereinbefore explained with reference to the modifications, Sheets 12 and 13.

The accumulating-carrier 60 may be driven by the train of gears shown in Fig. 21, which will be arranged upon either side of the machine, as may be desired, it being understood that the toothed wheel 61 may be placed at either end of the shaft of said carrier.

What have been described as rollers carrying tapes may be pulleys set upon a common shaft.

It is obvious that either of the accumulating mechanisms shown in the Patent No. 196,502, granted October 23, 1877, to S. D. Tucker, may be substituted for that shown herein without departing from this invention.

It is also obvious that any one of the following folding mechanisms may, in like manner, be substituted for the carrier 30, its rotary folders, and their co-operating mechanisms, viz: First, any form of folder wherein a vibrating folding-blade, as 75, doubles the sheets into the nip of folding-rollers, as 74; second, the modified folding mechanism shown in Sheets 9 to 12 of the Patent No. 171,196, granted to S. D. Tucker, December 14, 1875; third, the folding mechanisms shown in Figs. 10 and 11 of the Patent No. 196,502, October 23, 1877, hereinbefore mentioned.

It is further obvious that the sheets, either singly or associated in pairs, may be carried between the folding-blade supported by the carrier 30, (or its equivalent found in the patents mentioned above,) and the devices co-operating therewith, without being supported upon or by such carrier, as in Sheet 14.

The vibrating folding mechanism herein



shown may be of the rotating order, as in Fig. 48 of the aforesaid Patent No. 191,494.

The rotary folders supported by the carrier 30 may be three, four, or more in number, when the said carrier will be increased to three, four, or more times the diameter of the accumulating-carrier 60.

The rotary folders in the carrier 30, whether one or more in number, may be provided with single or double folding-blades, their flying-cams be single or double, and said devices operated as is shown in Sheets 8 and 9, and described in the said Patent No. 191,494.

The following is not claimed herein: printing, cutting, web or sheet controlling, and rotary folding mechanisms, in any combination with each other, nor an accumulating-carrier provided with two points of delivery, which are occupied by sheet-controlling switches.

What is claimed is—

1. An independent rotating sheet-accumulating carrier, combined with a rotating folding-blade carrier, said carriers being mounted upon parallel axes, and provided with means for directing the sheets from one to the other, all substantially as described.

2. An accumulating-carrier and a folding-blade carrier mounted upon parallel axes, and combined with means which deliver sheets from one to the other, all substantially as described.

3. An accumulating-carrier, in combination with a folding-blade carrier, each of said carriers being provided with grippers for transferring sheets from one to the other of said carriers, all substantially as described.

4. An independent rotating sheet-accumulating mechanism, provided with means for receiving sheets at one point and for delivering the same at two points, in combination with an independent folding mechanism mounted upon an axis parallel with that of the accumulating mechanism, and with independent mechanism for flat delivery, all substantially as described.

5. The combination of an accumulating-carrier with a folding-blade carrier of two, three, or more times its diameter, which latter is furnished with two, three, or more folding devices, all substantially as described.

6. The combination, with the accumulating-carrier and the folding-blade carrier, of the rocking cam 98, whereby the former carrier is operated to collect or associate sheets and deliver the same to the latter, substantially as described.

7. The combination, with carriers, as 60 30, provided with grippers, of a cam, as 98, having arms 54 26, substantially as described.

8. The combination of the swinging cam 98, adjusting-screw 9, and carriers 60 and 30, substantially as described.

9. The combination of the cam 98, eccentric-rod 100, and carriers 60 and 30, substantially as described.

10. In combination with a sheet-gage, a mechanism constructed substantially as described, and operating automatically to deflect a traveling sheet, so that alternate sheets shall pass said gage.

11. The lifting-rod 91, in combination with the tapes 72 73 and gage 97, substantially as described.

12. The combination of folding-rollers 66 67, slowly-moving receiving-rollers 59 57, folding-rollers, as 74 141, and stops 96 97, whereby the rearmost of a pair of sheets, separated a distance apart as the latter emerges from the rollers 66 67, is caused to gain upon the foremost sheet of the pair, and the two thus move into register at about the same time against their respective stops, all substantially as described.

13. A rotating folding-blade carrier provided with two sets of sheet seizing and releasing grippers, and with means for rendering one set of said grippers inoperative, all substantially as described.

14. The combination, with a rotating carrier supplied with devices for collecting or accumulating many sheets thereon, of a switch to deliver said sheets in a single mass or body therefrom, and a folder-carrier furnished with means for receiving and folding said sheets, all substantially as described.

In testimony whereof I have signed my name to this specification in the presence of two subscribing witnesses.

STEPHEN D. TUCKER.

Witnesses:

H. T. MUNSON,  
M. B. PHILIPP.