

S. D. TUCKER.
Sheet-Delivering Apparatus for Printing-Machines.
No. 197,694. Patented Nov. 27, 1877.

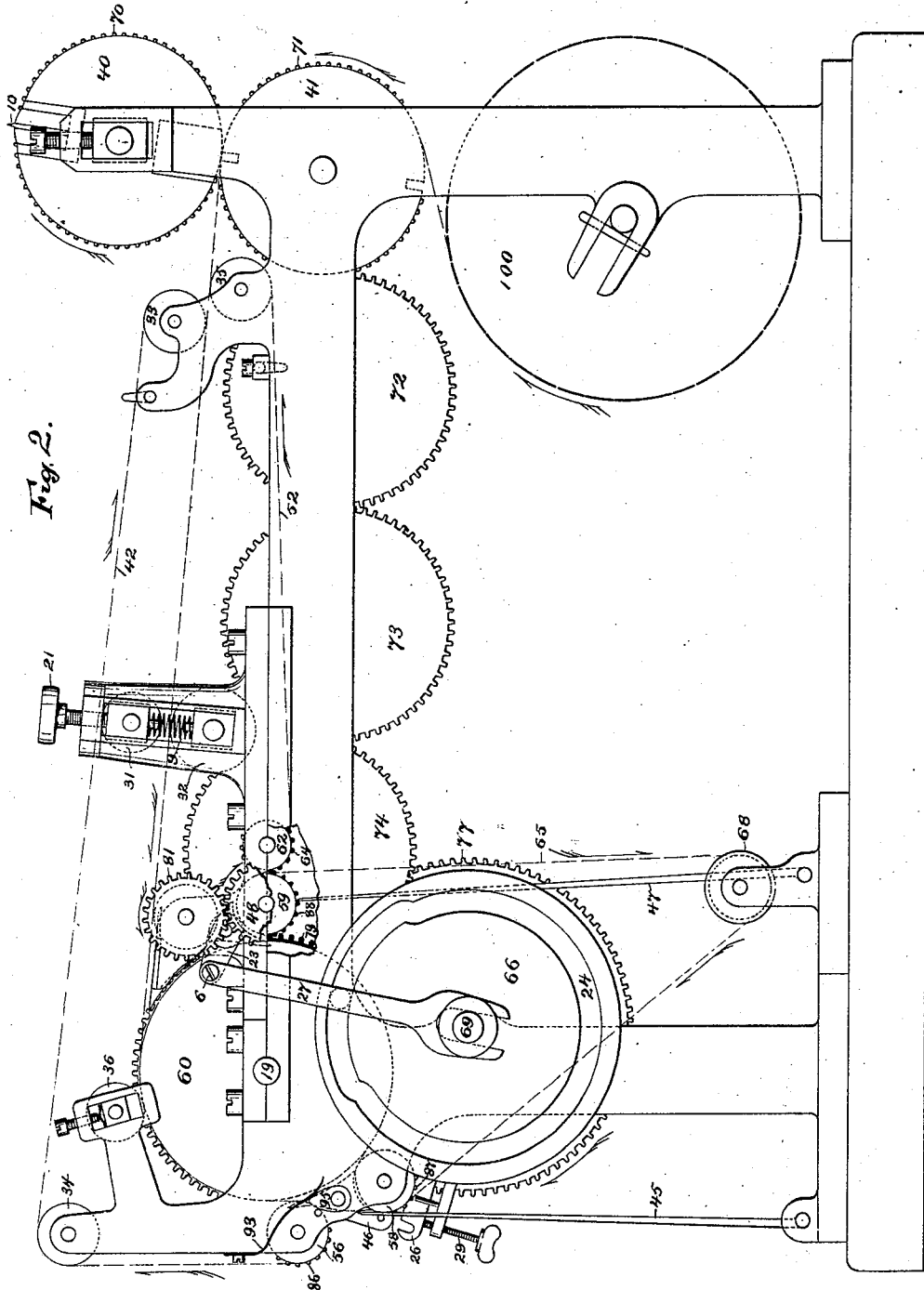

Fig. 2.

Witnesses
Geo. H. Graham.
W. C. Heepe

Inventor
Stephen D. Tucker
By Munson & Philipp,
Attorneys

S. D. TUCKER.
Sheet-Delivering Apparatus for Printing-Machines.
No. 197,694. Patented Nov. 27, 1877.

Fig. 3.

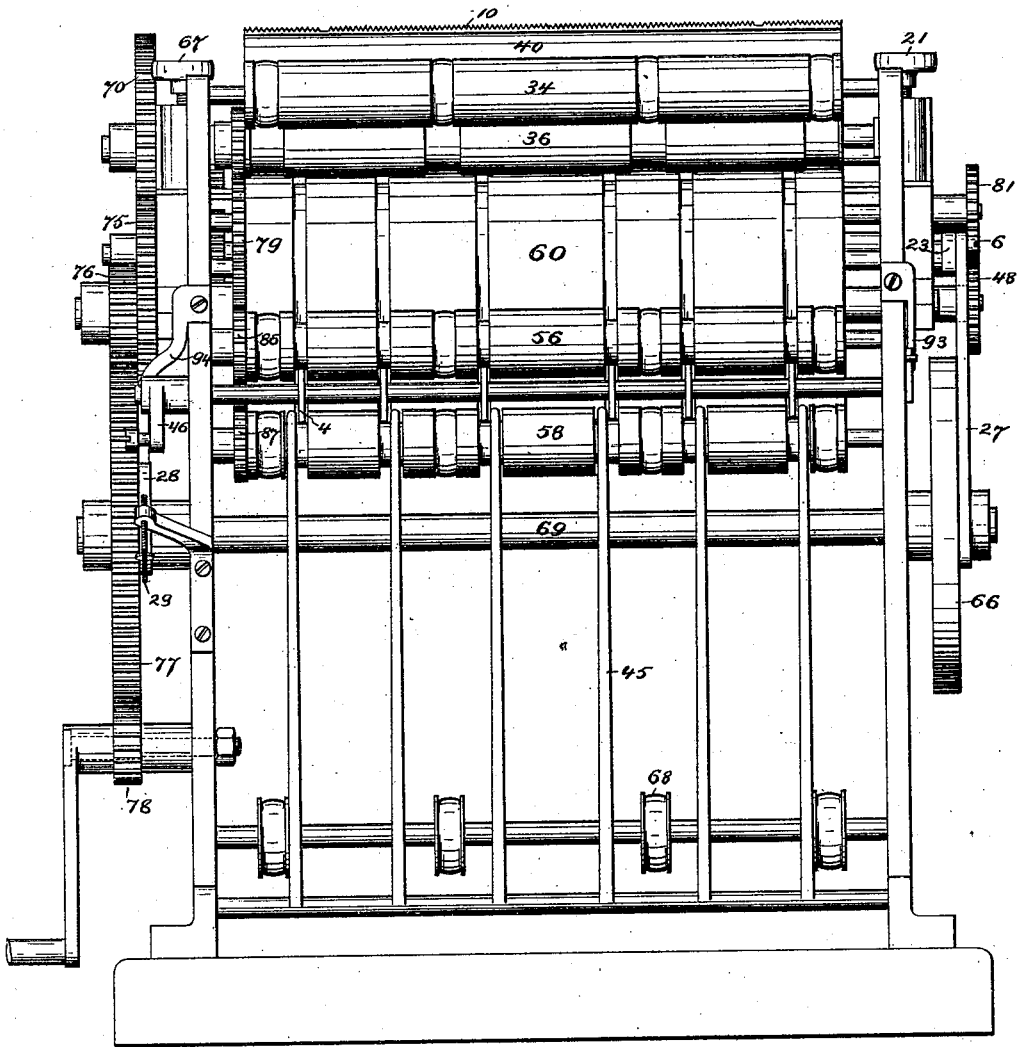

Witnesses
G. H. Graham
W. L. Hespe.

Inventor
Stephen D. Tucker
By Munson & Phillips
Attorneys

S. D. TUCKER.

Sheet-Delivering Apparatus for Printing-Machines.

No. 197,694.

Patented Nov. 27, 1877.

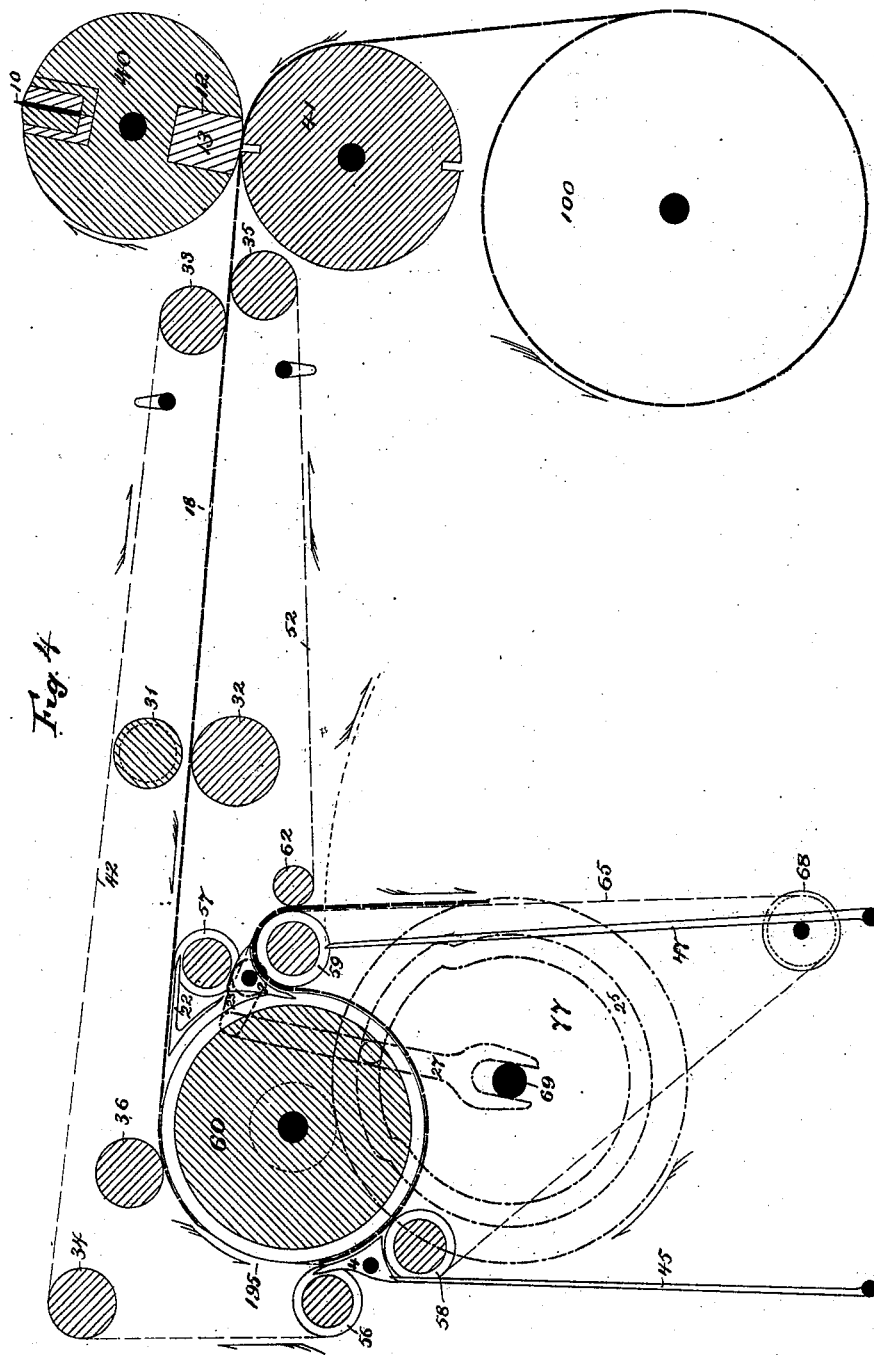

Fig. 4

Witnesses
Geo. Graham
W. C. Hesper

Inventor
Stephen D. Tucker
 By *Miner Philipp*
 A *Hornes*

S. D. TUCKER.
Sheet-Delivering Apparatus for Printing-Machines.
No. 197,694. Patented Nov. 27, 1877.

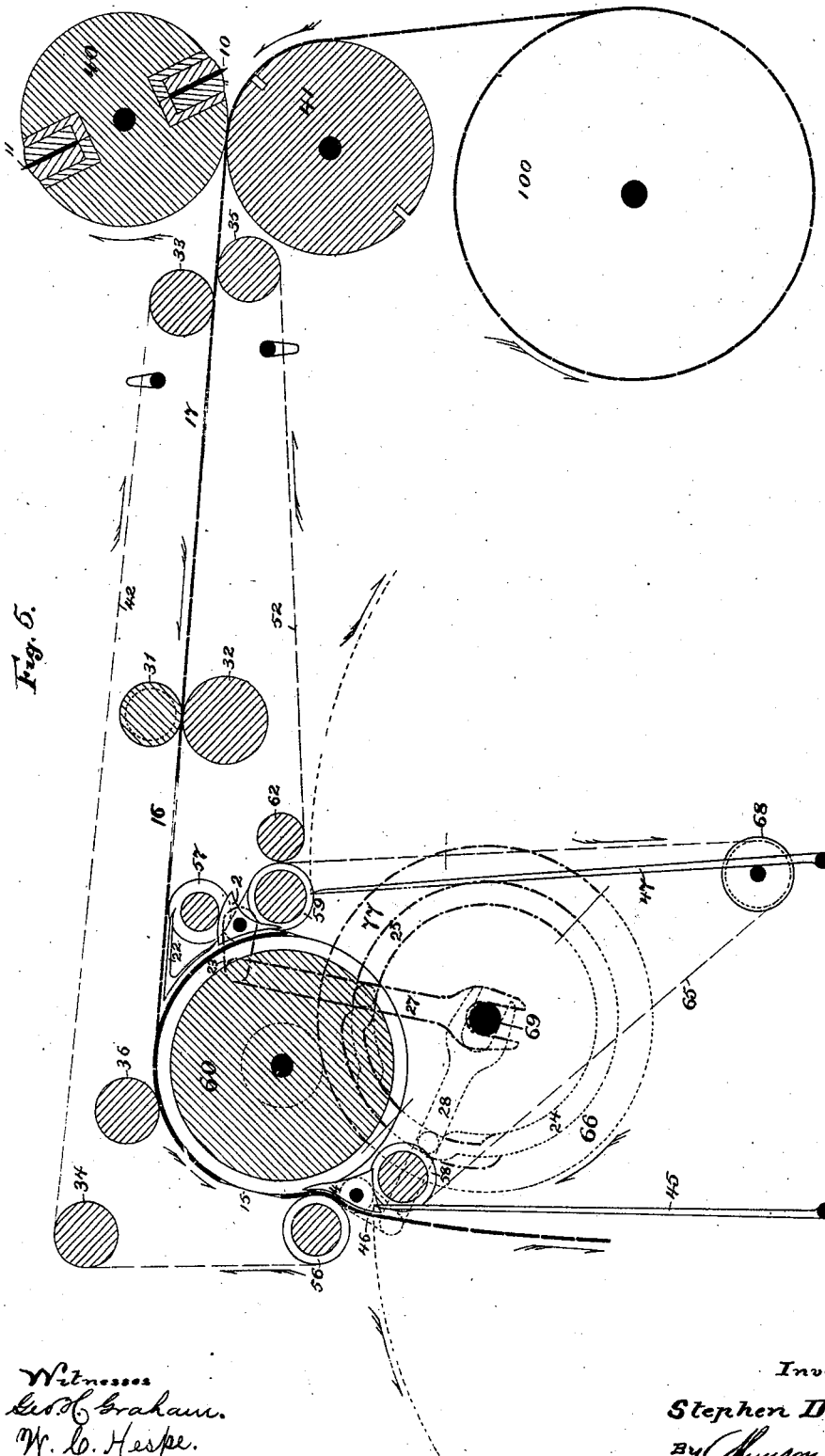

Fig. 5.

Witnesses
Edw. Graham.
W. L. Herpe.

Inventor
Stephen D. Tucker
By *Johnson & Phillips*
Attorneys.

S. D. TUCKER.
Sheet-Delivering Apparatus for Printing-Machines.
No. 197,694. Patented Nov. 27, 1877.

Fig. 6

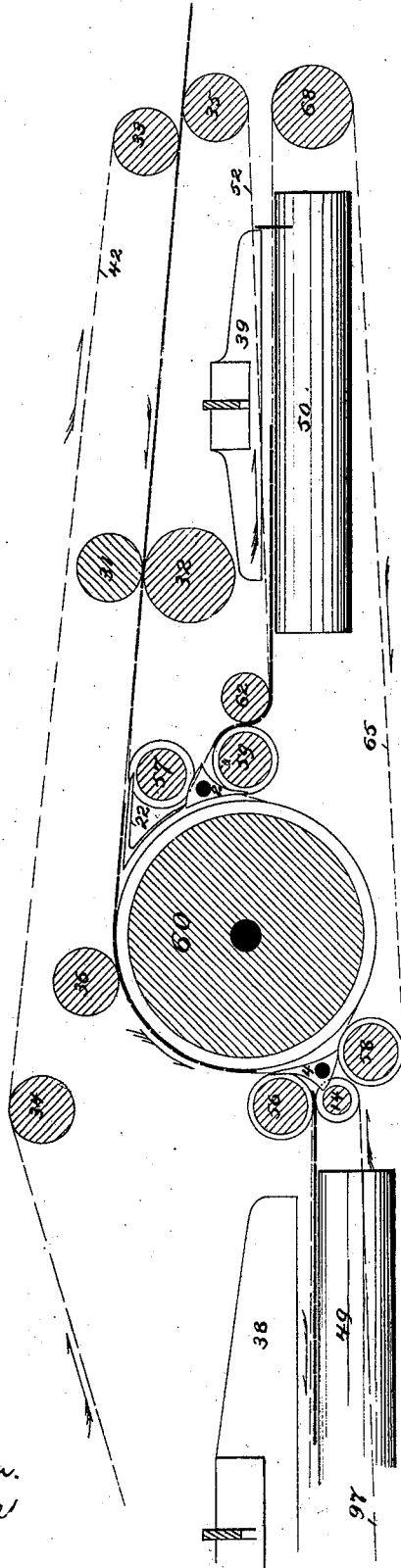

Witnesses
G. H. Graham.
W. L. Nespe

Inventor
Stephen D. Tucker
By Munson & Philipp.
Attorneys

S. D. TUCKER.
Sheet-Delivering Apparatus for Printing-Machines
No. 197,694. Patented Nov. 27, 1877.

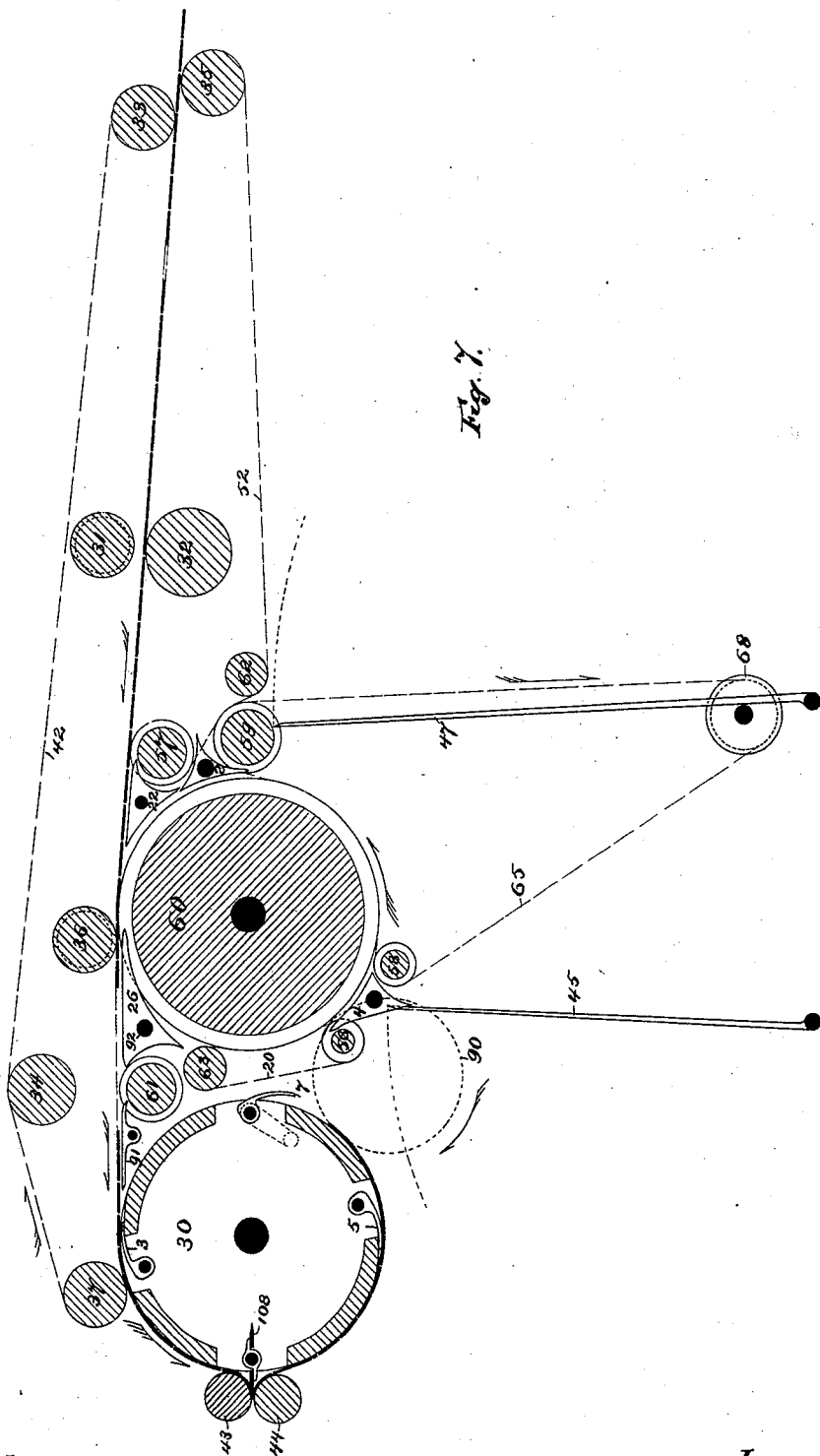

Fig. 7.

Witnesses
L. W. Graham
W. C. Hespe.

Inventor
Stephen D. Tucker
By *Mason & Phillips*
Attorneys

S. D. TUCKER.
Sheet-Delivering Apparatus for Printing-Machines.
No. 197,694.
Patented Nov. 27, 1877.

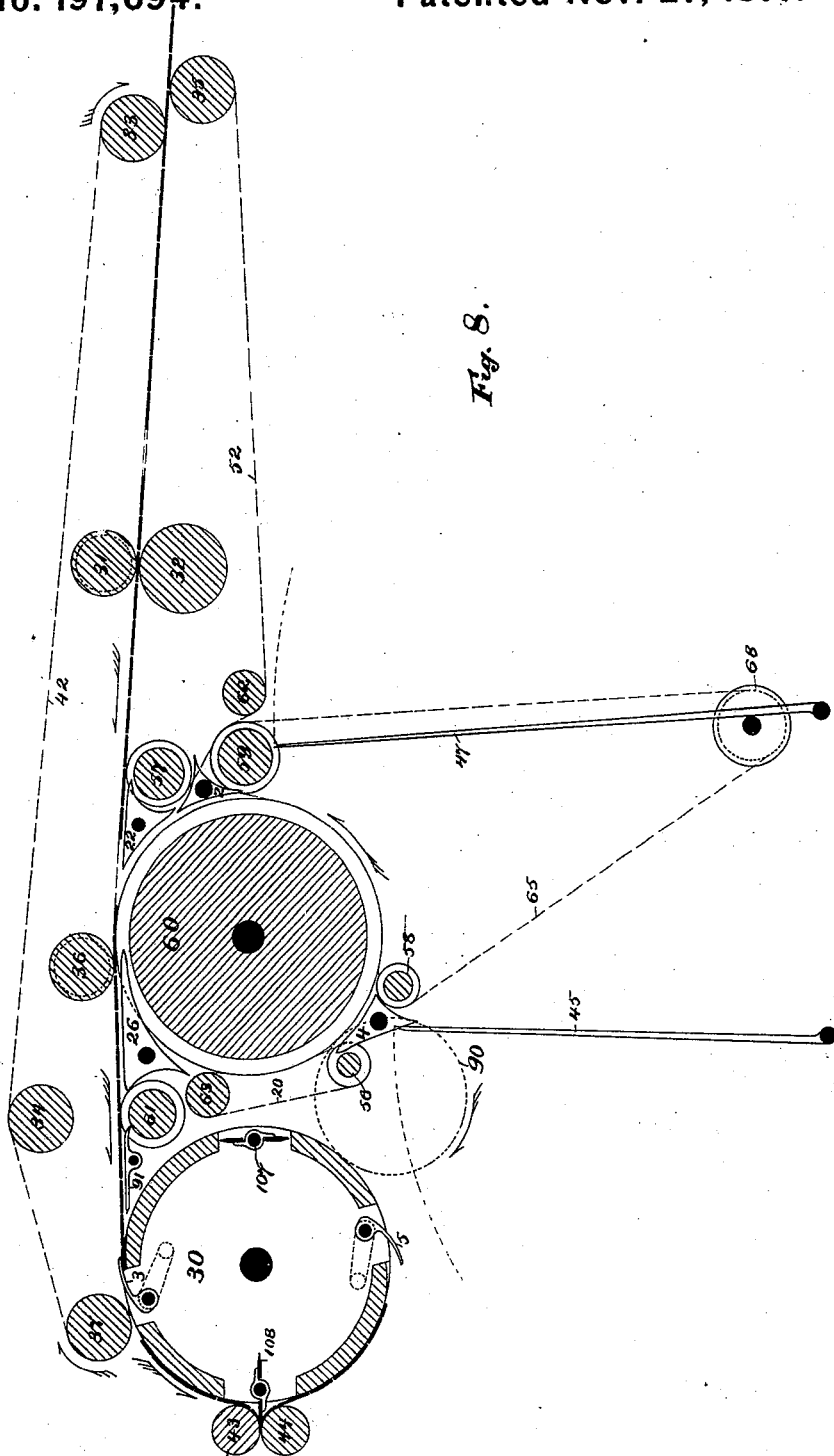
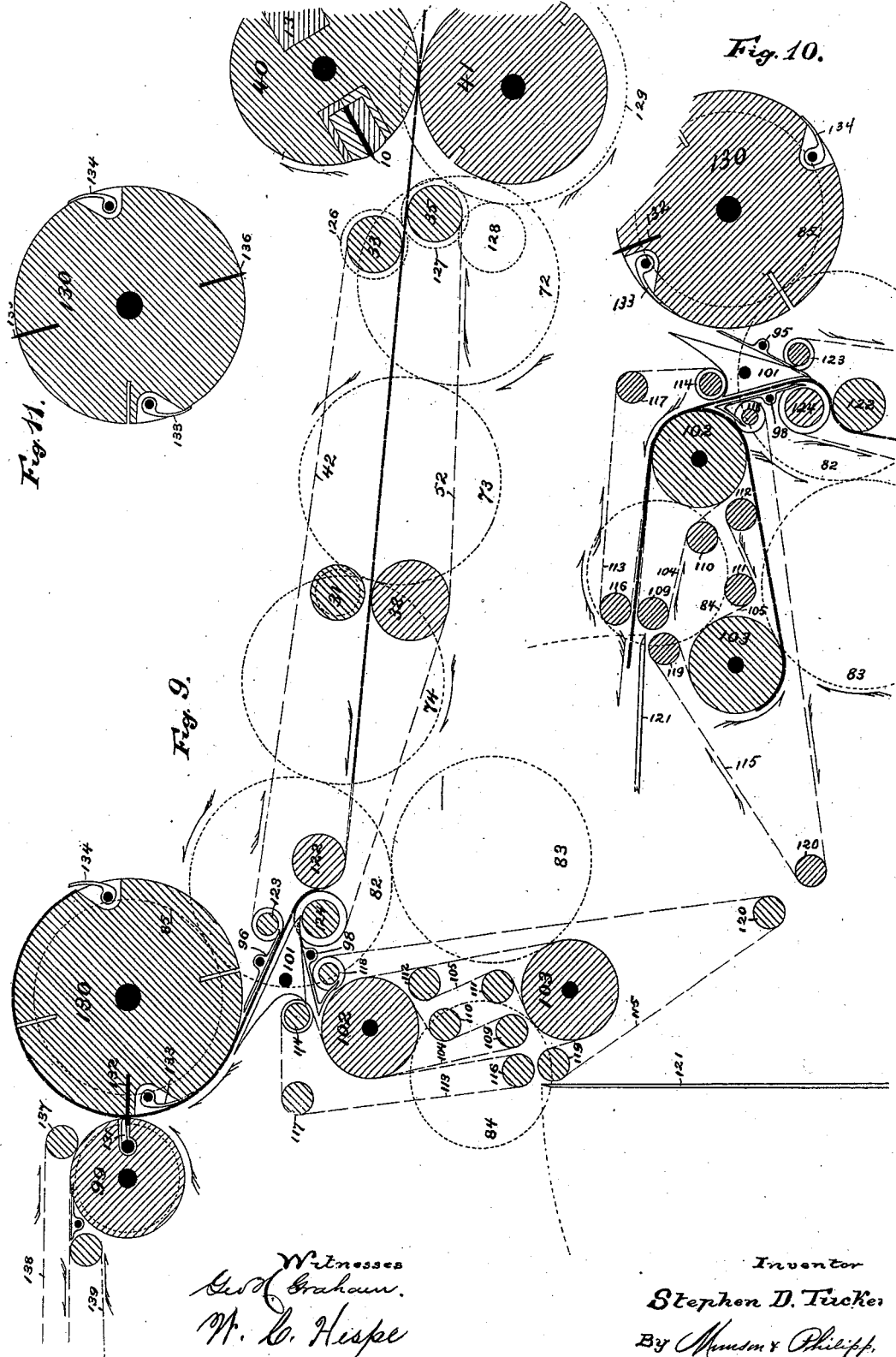

Fig. 8.

Witnesses
C. H. Graham.
W. L. Herpe

Inventor
Stephen D. Tucker
By *Mundm & Philipp*
Attorneys

S. D. TUCKER,
Sheet-Delivering Apparatus for Printing-Machines.
No. 197,694. Patented Nov. 27, 1877.



Witnesses
Geo. Graham.
W. C. Hisee

Inventor
Stephen D. Tucker
By *Munden & Philipp,*
Attorneys.

S. D. TUCKER.
Sheet-Delivering Apparatus for Printing-Machines.
No. 197,694. Patented Nov. 27. 1877.

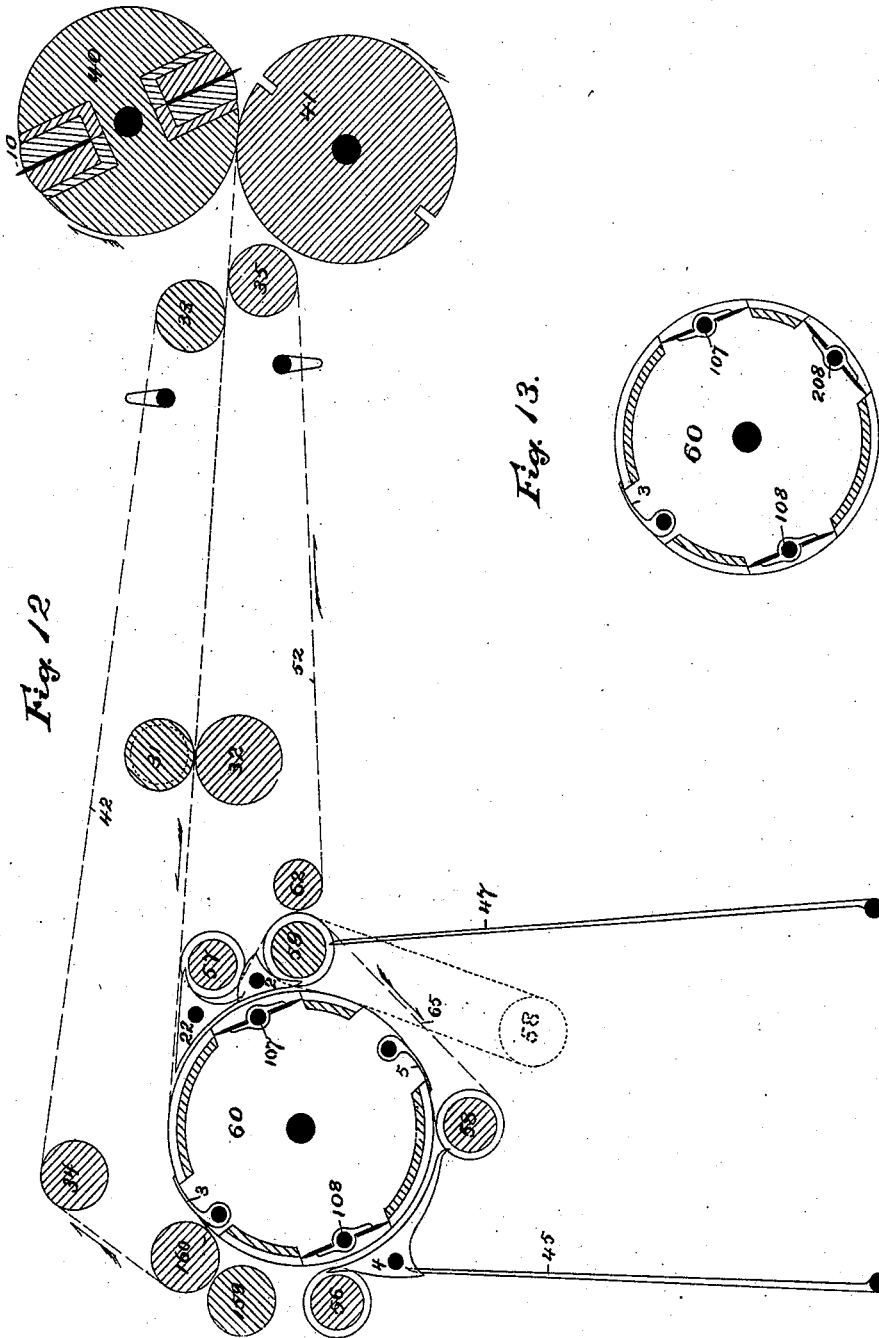

Fig 12

Fig 13.

Witnesses
Geo. C. Graham.
W. C. Kesper

Inventor
Stephen D. Tucker,
By Messrs & Phillips,
Attorneys

UNITED STATES PATENT OFFICE.

STEPHEN D. TUCKER, OF NEW YORK, N. Y.

IMPROVEMENT IN SHEET-DELIVERING APPARATUS FOR PRINTING-MACHINES.

Specification forming part of Letters Patent No. **197,694**, dated November 27, 1877; application filed November 21, 1877.

To all whom it may concern:

Be it known that I, STEPHEN D. TUCKER, of the city, county, and State of New York, have invented an Improvement in Delivering Apparatus for Printing-Machines, of which the following is a specification:

This invention relates to that class of delivering apparatus for printing-machines which are adjustable so as to adapt them to the manipulation of different-sized sheets.

It consists, mainly, in providing such an apparatus with an additional sheet-nipping device, located between the cutting-cylinders and the delivering apparatus, whereby sheets of different sizes are detached from the web, if necessary, and separated a distance apart to facilitate their accurate manipulation. It also embraces an accumulating-carrier provided with one point of entrance and with two or more points of delivery for the sheets, whereby two or more different-sized sheets may be delivered, and the combination therewith of mechanisms for folding said sheets or piling them flat, all of which will be more particularly hereinafter described.

Modifications and details of construction are also included in the invention, but are not fully hereinafter pointed out to need preliminary description.

In the drawings, forming a part of this specification, is illustrated, in Figure 1, a right-hand side elevation of my improved delivering apparatus. Fig. 2 is a left-hand side elevation of the same; Fig. 3, a rear elevation; Fig. 4, a longitudinal section, showing the operation of delivering large or full-sized sheets; and Fig. 5 is a similar view, showing the operation of delivering small or half-size sheets. Fig. 6 shows a modification, embodying a gathering or accumulating mechanism and two independent folding mechanisms. Figs. 7 and 8 are longitudinal sections of a further modification of the apparatus, which embodies independent gathering or accumulating and folding mechanisms, the former showing the operation of manipulating full-sized sheets, and the latter the operation of manipulating half-sized sheets. Figs. 9, 10, and 11, show a further modification, embodying independent gathering or accumulating and folding mechanisms and a sheet-directing mechanism. Fig.

12 shows a modification, wherein the accumulating carrier is provided with grippers and folding-blades, Fig. 13 showing the same with one set of grippers and three rotary folding-blades adjusted in place.

This delivering apparatus, though it may receive sheet after sheet directed between the cylinders 40 41 by hand or an automatic feeding mechanism, is designed to be attached to a printing-machine, and particularly to that class of such machines known as "web-perfecting," which, operating upon paper in the web, print the same and sever it into appropriate-sized sheets.

The cutting-cylinders 40 41, herein shown, may be those of a web-perfecting printing-machine. They are geared together by toothed wheels 70 71, and the male cutting-cylinder 40 may be of the same size, and run turn for turn with the type-cylinders of said printing-machine.

The accumulating-carrier 60 is somewhat larger than the cutting-cylinders, and is caused to make equal turns in unison therewith by a train of intermediate toothed wheels 72 73 74, the wheel 72 gearing with the toothed wheel 71, and the wheel 74 gearing with a similar wheel, 75, fast on the shaft 19 of said carrier. A pinion, 76, on said shaft 19 gears with the toothed cam-wheel 77 on the shaft 69, which latter wheel drives a cam-wheel, 66, on the opposite end of said shaft 69.

Though a driving pinion, 78, engaging with the toothed cam-wheel 77, is herein shown as a means for imparting motion to the apparatus, said motion will, in practice, be derived from one of the moving shafts of the printing-machine, and may be transmitted by a train of gear-wheels meshing with one of the toothed wheels of this apparatus, preferably that carried on the shaft of one of the cutting-cylinders. Any other connection may be made, such as a longitudinal shaft and bevel-wheels.

The paper is directed from the cutting-cylinders 40 41 to the accumulating-carrier by means of conveying-tapes 42 52, the upper set, 42, of which are stretched from a roller, 33, near the upper cutting-cylinder to and in contact with a portion of the surface of the carrier 60, around a roller, 56, and return over a carrying-roller, 34, to the said roller 33. The other

set, 52, are stretched from a roller, 35, placed beneath roller 33, and near the lower cutting-cylinder; thence around a roller, 57, and return over a roller, 59, and under a roller, 62, to the said roller 35. A third set of tapes, 65, are stretched over rollers 68 58 59, passing in contact with the carrier 60 between said rollers 58 59, and down before the fly-frame 47 between said rollers 59 68. The roller 56 has a toothed wheel, 86, the roller 58 a toothed wheel, 87, and the roller 59 has a toothed wheel, 88, all of which wheels gear with and are driven by a toothed wheel, 79, fast upon the shaft 19 of the carrier 60, and the roller 62 has a toothed wheel, 64, which meshes with the toothed wheel 88, while the roller 57 is driven by a toothed wheel, 81, which meshes with a toothed wheel, 48, on the shaft of roller 59. All of these rollers are thus given the same surface-speed as said carrier 60. There is also a draw-filed pressing-roller, 36, mounted in contact with the carrier 60 at its upper side, and driven by a gear, 80, meshing with the toothed wheel 79, the purpose of which will hereinafter be fully explained.

By this arrangement of tapes and tape-rollers the carrier 60 is provided with one point of entrance for the sheets, viz., when the tapes 42 pass onto its surface, and with two points of delivery, viz., between the rollers 56 58 and the rollers 57 59. At the entrance-point there is a conductor, 22, which is so shaped as to form a bridge between the roller 57 (around which the tapes 52 are returned) and the surface of the carrier 60, and to form a guard curved to coincide with the surface of said carrier between said roller 57 and the points where the tapes 42 meet the surface of said carrier. At these delivery-points of this carrier 60 are provided switches 4 2, which swing in grooves in the carrier 60, and rollers 56 58 and 57 59, so as to retain sheets upon said carrier or guide them off, as in Fig. 5. The switches 4 are hung on a shaft provided with a rock-arm, 46, and a connecting one, 28, whose stud or friction-roller runs in a cam-groove, 25, in the toothed cam-wheel 77, and the switches 2 are hung on a shaft provided with a rock-arm, 23, and a connecting-rod, 27, whose stud or friction-roller runs in a cam-groove, 24, in the cam-wheel 66, the two sets of switches being thus automatically rocked into and retained in proper positions at predetermined intervals, as will be fully explained.

The switches 4 may be rendered inoperative by uncoupling the connecting-rod 28 from their rock-arm 46, which may be done in any common manner. As here shown, this is accomplished by an adjusting-screw, 29, which holds said rod 28 in either of the positions shown in Figs. 1 and 5. The switches 2 may be rendered inoperative by removing the screw 6, which connects the rod 27 with their rock-arm 23.

A pair of nipping-rollers, 31 32, between which the conducting-tapes 42 52 run, are mounted between the carrier 60 and the cut-

ting-cylinders 40 41, and are driven by means of a toothed wheel, 55, which gears with the toothed wheel 74. The upper of this pair of rollers is mounted in movable boxes, so that it may be adjusted by means of thumb-screws 67 21 into and out of contact with its companion lower roller, it being seated upon springs 8 9 to facilitate its upward movement. These rollers, (having draw-filed or otherwise roughened surfaces,) when adjusted in working contact, constitute a sheet or web nipping device.

The cutting-cylinder 40 is provided with a cutting-blade, 10, which is fixed so as to project from its periphery a suitable distance, and with a socket, 12, which is adapted to receive a second cutting-blade, 11, as in Fig. 5. When this cutting-blade 11 is removed its socket may be filled by a block, as 13.

The cutting-blades 10 11 may be constructed, held in place, and removed as is described and illustrated in the Patent No. 180,966, granted to S. D. Tucker, August 8, 1876; or they and the block 13 may be secured by screws passing through the cylinder and tapped into them, as described in the Patent No. 196,502, granted to S. D. Tucker, October 23, 1877.

Furthermore, either of said blades may be rendered inactive, as in the Patent No. 191,494, granted to S. D. Tucker, May 29, 1877.

The nipping-rollers 31 32, the switches 4, and the two cutting-blades 10 11 are brought into operation when the web is to be severed into small or half-size sheets, and the same are to be manipulated, which operation will be particularly hereinafter described.

The apparatus provided with the mechanisms thus far described may be adopted:

(A) to sever the web into large or full-sized sheets, collect or accumulate two or more such sheets upon the carrier 60, and deliver the same in a single body therefrom at the switches 2 to the fly-frame 47, which will lay them flat upon a piling-table:

(B) to sever the web into small or half-size sheets, collect or accumulate two or more such sheets in two distinct bodies upon the carrier 60, and deliver the same, one body at the switches 4 to the fly-frame 45, and the other body at the switches 2 to the fly-frame 47, which fly-frames will lay such bodies of sheets flat upon piling-tables.

To perform the operation described in paragraph A, the mechanisms are adjusted as in Figs. 1 to 4, wherein one cutter, 10, only is in place or operative in the cylinder 40. The nipping-rollers 31 32 are separated and inoperative, and the switches 4 are caused to remain in the position Figs. 1, 2, 3 by means of the spring 93, which bears upon an arm, 95, fast on one end of their shaft, their actuating-rod 28 being uncoupled from the rock-arm 46, and so held by a spring, 94. (See Fig. 1.)

The web of paper emerging from the printing-cylinders (herein shown for convenience as led from a reel, 100) is directed between the cutting-cylinders 40 41, as in Fig. 4, which sever or partially sever it transversely upon

lines which divide it into large-size sheets. It is thence conveyed by the tapes 42 52 onto the carrier 60, and when its leading end is caught between the tapes 42 or roller 36 and the surface of said carrier 60 (which constitutes a sheet or web nipping device) it is caused to travel with a speed accelerated beyond that imparted to it by the cutting-cylinder 40 41; and if it has been severed by the said cutting-cylinders, the sheet will be rapidly advanced, so as to separate it a distance from the end of the web, as at 18; or if the web is but partially severed by said cutting-cylinders it will be torn from the web on the dividing-line, and the sheet thus formed will be rapidly advanced and separated from the end of the web, as above stated. This space between the sheets causes their heads and tails to be in like manner separated, as at 195, when the sheets are laid upon the carrier 60, and provides for the operation of the switches 2.

The first incoming sheet nipped upon the surface of the carrier 60 passes around with it, being held thereon by the tapes 42 65 and conductors 22 until its head or leading edge reaches the entrance-point, where a second sheet is in like manner received, laid upon the first, and the two caused to pass together under the roller 36 and around the carrier 60.

Any convenient number may thus be collected or accumulated, one on the other, upon the carrier 60, and when the predetermined number (four in this instance) have been so collected, which is determined by the proportionate size of the toothed wheel 77, which drives the switch, moving cam-wheel 66 to its pinion 76, the switches 2 will be rocked into the position, Fig. 4, so that their toes will intercept the leading edges of the collected sheets and direct the same in a single body onto the roller 59, between it and the roller 62, and down before the fly-frame 47, which, vibrated in proper time by any common means, will lay the same flat upon a piling-table. As the tails of this body of collected sheets pass the switches 2, said switches are rocked, so that their faces coincide with the periphery of the carrier 60, as in Fig. 5, in which position they guide the single sheet, which has meanwhile passed onto the carrier 60 onward to the entrance-point, to meet and receive upon it the next incoming sheet, and repeat this collecting and delivering operation.

To perform the operation described in paragraph B, the apparatus is adjusted as follows: The second cutter, 11, is adjusted in position or thrown into operation, as in Fig. 5, the second web or sheet nipping device is brought into operative position by adjusting the roller 31 into surface-contact with its companion 32, and the connecting-rod 28 is coupled to the switch-operating rock-arm 46. The web directed between the cutting-cylinders 40 41 will then be severed, or partially severed, by the cutting-blades 10 11 upon transverse lines, dividing it into sheets one-half the size of the former ones. The leading end of the sheet or

web will then be caught between the nipping-rollers 31 32, (which are geared to run at the same surface-speed as the carrier 60,) which will advance the same at an accelerated speed, and separate the sheet a distance from the web, if the latter is entirely severed by the cutting-blades, or tear the sheet from the web and separate it a distance therefrom, as at 17; and this same sheet will, after passing through the nipping-rollers 31 32, be caught between the tapes 42 or roller 36 and the carrier 60, which will advance it at the same speed as that imparted to it by the said rollers 31 32, thus preserving the space between the heads and tails of the sheets, as at 15 16, which space, although only half that between full-sized sheets, as in paragraph A, permits the perfect operation of the switches 4 and 2.

The first sheet passing onto the carrier 60 will extend over nearly one-half of its periphery, and the second sheet will pass onto and nearly cover the other half of its periphery, the heads and tails of the sheets being separated a distance apart, as at 15. The third sheet will pass onto the first, the fourth onto the second, and so on until the predetermined number has been collected in like manner, as hereinbefore described with reference to full-sized sheets, but in two bodies instead of one. This number is determined by the proportion of the pinion 76 to the toothed wheel 77, which latter has the cam-groove 25, and drives the cam 66. As herein arranged this number is four, and hence, when the heads of the body of sheets consisting of those received in the order 1 3 5 7 approach the switches 4, said switches will have been rocked into the positions, Fig. 5, to intercept the same, and direct the said body of sheets over the roller 58 and down before the fly-frame 45, which will be vibrated to deliver the same flat upon a piling-table. When the tails of this body of sheets have passed the switches, said switches will be rocked into the position Fig. 4, and guide the heads of the body of sheets received in the order 2 4 6 8 onward toward the switches 2, which will then have been rocked into the position shown in Fig. 4, as before described, and direct said body of sheets down before the fly-frame 47.

These operations will be repeated, and the following sheets will be collected in two distinct bodies upon the carrier 60 and delivered in like manner.

Instead of discharging one-half of the small-size sheets by the switch 4, and one-half by the switch 2, they may all be discharged by the latter switch, by replacing the switch-cam and fly-cam by others that will operate the switch 2 and fly 47 twice during four revolutions of the carrier 60, and these times must be at every one and one-half and two and one-half revolutions of the same. This difference of one-half a revolution over and under two, the average, will cause the switch to strike alternately into the space between the half-sheets at opposite sides of the carrier,

the object being to discharge the sheets in parcels of four with an interval between them. If it is desired to discharge the half-size sheets in parcels of any uneven number, say, five or seven, then the cams must actuate the switch and fly at every two and one-half or three and one-half revolutions of the carrier, as the case may require; but it is preferable to provide one sheet-flier for the full-size sheets and two for the half-size sheets, as before described.

Instead of delivering its product to the fly-frames 45 47, the switches 2 4, at the two points of delivery of the carrier 60, may direct the sheets to one folding mechanism and to one fly-frame, as in Sheet 12 of a companion application filed November 6, 1877, or to two folding mechanisms, as in Fig. 6 hereof. In this modification the tapes, 42 52 are extended, the former to lead out over the folding-rollers 49, and the latter to lead out over the folding-rollers 50. A third set of tapes, 97, run from rollers 14 and act with the tapes 42 as conductors to direct the sheets from switch 4, and the tapes 65 are extended so as to act with the tapes 52 as conductors to direct the sheets from the switches 2.

Thus modified the apparatus may operate as follows:

(C) Two or more full-size sheets may be accumulated upon the carrier 60, directed by the switches 4 out over the folding-rollers 49, and doubled through the same by a vibrating folding-blade, 38.

(D) Two or more half-size sheets may be accumulated in two distinct bodies upon the carrier 60, and each alternate body of such collected sheets be directed by the switches 4 and 2 out over the folding-rollers 49 and 50 and doubled through the same by the vibrating folding-blades 38 39; or two successive bodies of said half-size sheets may be directed alternately to the folding-rollers 49 50.

In the operation, paragraph C, one cutter, the nipping-rollers 31 32, and the switches 2 must be rendered inoperative, while in the operation, paragraph D, the two cutters 10 11, the nipping-rollers 31 32, and the switches 4 2 must all be put into operation.

This modification of the apparatus is also adapted to perform the operations hereinafter described in paragraphs E and F, when the operation of the switches 2 and 4 is properly timed. The apparatus may be supplemented with an independent folder-carrier and mechanism connecting the same with the accumulating-carrier, as in the said companion application filed November 6, 1877. Such a modification of it is shown in Figs. 7 to 10, wherein a rotary carrier, 30, mounted parallel with and a distance beyond the accumulating-carrier 60, is provided with a toothed wheel (not shown) upon one end of its shaft, which wheel is connected by an intermediate toothed wheel, 90, with the toothed wheel 75 upon the shaft of carrier 60, by which gearing the said car-

riers 30 60 are caused to run in unison and turn for turn.

The mechanism connecting the two carriers together is formed as follows: The tapes 42 are stretched beyond the pressing-roller 36, pass over a roller, 61, around a roller, 37, and return over the carrying-roller 34 to the roller 33. The space beneath these tapes and between the two carriers is occupied by a driving-roller, 61, a conductor, 91, and a switch, 26. The driving-roller 61 is provided with a toothed wheel on its shaft, which is geared by an intermediate wheel on the roller 63 with the toothed wheel 75 on the shaft of carrier 60, which gearing (not shown herein) will be readily understood by reference to Fig. 32 of the before mentioned companion application, filed November 6, 1877. The switches 26 (which play in grooves in the carriers 60 and rollers 36 61) are mounted on a shaft, 92, which, by means of a rock-arm and a connecting-rod, whose stud or roller runs in a properly-shaped groove of a cam-wheel mounted upon the shaft 69, will be rocked at suitable intervals to direct each sheet, or each successive body of two, three, or more sheets associated together upon the accumulating-carrier 60, to the folding-carrier 30 in manner fully shown in Sheets 12 and 13 of, and described in, said companion application, filed November 6, 1877.

The switches 26 and tapes 42, or roller 36, constitute a point of delivery for the sheets from the carrier 60, and, with the others hereinbefore described, form three such points of delivery.

A short set of tapes, 20, running from the roller 56 to the roller 63, cover that portion of the carrier 60 between the switches 26 and 4.

The folding-carrier 30 is equipped with a rotary folder, 108, which is constructed and operated as in the said companion application, filed November 6, 1877. This carrier is also armed with three sets of grippers, 3, 5, and 7, which are mounted upon rock-shafts in the heads of said carrier, and operated at proper times or rendered inactive by similar means and substantially as in said companion application, filed November 6, 1877.

The apparatus thus modified may be adjusted to perform the operations hereinbefore described in paragraphs A and B, at which time the switches 26 are rendered inactive, and sustained in a position where their toes enter the grooves in the roller 36, by removing the stud or roller from their connecting-rod, or sliding its actuating cam-wheel out of contact therewith. It may also be adjusted and operate:

(E) To sever the web into full-size sheets, and direct each successive sheet to the carrier 30 to be folded and delivered from between the folding-rollers 43 44.

(F) To sever the webs into full-size sheets, collect two or more such upon the carrier 60, and deliver such associated sheets in a single body to

the carrier 30, which will fold the same, and deliver them as one product from between the folding-rollers 43 44.

(G) To sever the web into half-size sheets, and direct each successive sheet to the carrier 30, to be folded and delivered from between the folding-rollers 43 44.

(H) To sever the web into half-size sheets, collect or accumulate two or more such sheets in two distinct bodies upon the carrier 60, and deliver the same successively to the carrier 30, to be folded and delivered from between the folding-rollers 43 44.

To perform the operation, paragraph E, the cutting-cylinders have one cutting-blade in operation, the nipping-rollers 31 32 are adjusted out of operative contact, as in Fig. 4, and the switches 4 2 are thrown out of action and held in the position, Fig. 7, and the switches 26 are adjusted to remain in the position shown in Fig. 7. The actuating devices of the grippers 3 and 5 are also thrown out of action, so that said grippers remain closed and inactive, or they may be removed. Each sheet will then be directed by the tapes 42 52 to the carrier 60, nipped by the tapes 42 or roller 36, directed by the tapes 42, switches 26, and conductor 91, and moved by the driving-roller 61 onto the carrier 30, where the grippers 7 will seize and carry it around upon the surface of the carrier and before the folding-rollers 43 44, and release it at the proper time, as in Fig. 7, for it to be doubled by the rotary folder 108 through said folding-rollers.

To perform the operation, paragraph F, the switches 26 are thrown into action, so as to operate to direct the first incoming sheet onto the carrier 60, and the second, together with the first sheet, if two only are to be collected, onward to the carrier 30, which will fold the two together through the folding-rollers 43 44. In this operation the switches will stand with their toes in the grooves of roller 36 when the first sheet is received, and with their toes in the grooves of the carrier 60 when the second sheet is received, which movements will be imparted by a properly-shaped cam, as in the aforesaid companion application, filed November 6, 1877.

To perform the operation, paragraph G, the two cutting-blades are adjusted in operative position in the cylinders 40 41, and the nipping-rollers are adjusted in operative contact, as in Fig. 8, the grippers 7 are removed, and a rotary folder, 107, is adjusted in their bearings. The devices for actuating the grippers 3 and 5 are adjusted into operative position, and the switches 2 4 remain inactive, as before. Each half-sheet received is then directed to the carrier 30 and folded, as were the whole sheets, except that the first half-sheet received by said carrier is seized by the grippers 5 and folded by the rotary folder 108, and the second sheet is seized by the grippers 3 and folded by the rotary folder 107.

To perform the operation, paragraph H, the switches 26 are brought into operation, as be-

fore described with reference to the operation, paragraph F, so that two or more half-sheets are collected in two distinct bodies upon the carrier 60, and said bodies directed onto the carrier 30 and folded together successively through the folding-rollers 43 44. In this operation the folding-carrier will, when two sheets only are to be collected, make one idle revolution while the first sheets of each of the two bodies of sheets are passing onto the carrier 60. These two successive bodies of sheets may be conducted over the same folding-rollers and simultaneously doubled through them by the same stroke of the folding-blade, as in said companion application, filed November 6, 1877.

In the operations, paragraphs E and G, the carrier 60 operates simply to support the sheets guided onward to the carrier 30.

By a delivering apparatus furnished with a half-sheet nipping device, as rollers 31 32, and cutting-cylinders, having two cutting-blades, one of which is removable or capable of being rendered inoperative, either whole or half sheets may be directed to independent accumulating and folding mechanisms. This is illustrated in the modification, Figs. 9, 10, 11, wherein the accumulating and folding mechanisms, situated a distance apart, are provided with sheet-conductors 96 98, connecting them with the sheet-conducting tapes 42 52, which conductors have combined with them a moving sheet-directing mechanism which is capable of adjustment, so as to guide the sheets either to the accumulating or folding mechanism, as may be desired.

This sheet-directing mechanism, as here illustrated, is a switch, 101; but a swinging tape-frame may be employed, as in the aforesaid Patent No. 196,502.

The modified forms of accumulating and folding mechanisms shown in Figs. 9, 10, and which are fully described and illustrated in said Patent No. 196,502, may in some arrangements be adopted as substitutes for the similar mechanisms, Figs. 1 to 8.

As here shown, the accumulating-carrier consists of two cylinders, 102 103, set a distance apart, and connected together by means of tapes 104 105, which form, in connection with said cylinders, a carrier, the distance around which is just equal to the circumference of the folding-carrier 130, the two carriers being thus adapted to manipulate the same sizes of sheets. The tapes 104 are stretched around the cylinder 102, under a roller, 109, and over a roller, 110, and the tapes 105 are similarly stretched around cylinder 103, over a roller, 112, and down under roller 111. A set of tapes, 113, are stretched from a roller, 114, at the entrance-point of the sheets onto this carrier, pass in contact with the surface of the cylinder 102; thence under a roller, 116, and return over a roller, 117, to the said roller 114. Another set of tapes, 115, are stretched from a roller, 118, near said entrance-point of the sheets, pass down under roller

120, over roller 119, partially encompass the cylinder 103, and return, in contact with the surface of the cylinder 102, to the said roller 118. The rollers 116 109 are hung in a frame which is adapted to swing at proper intervals of time, and thereby rock the tapes 113 104 from the position shown in Fig. 9 to that shown in Fig. 10. Their adjustment in the position, Fig. 9, causes a sheet received upon the cylinder 102 to be directed onto the cylinder 103, and to return and pass around the cylinder 102, where it meets and receives a second sheet upon it, which sheets travel in an endless course about the carrier until three or any other predetermined number are thus accumulated, when the said tapes 113 104 will be rocked into the position, Fig. 10, whereby said accumulated sheets will be directed in a single body down before the fly-frame 121, and delivered flat upon a piling-table. The frame supporting the rollers 116 109 may be reciprocated by a cam or similar motion taken from any of the shafts of the machine, and the tapes 113 104 115 105 may be driven by the cylinders 102 103, or derive positive motion communicated by gearing to one or more of their carrying-rollers. The cylinders 102 103 will be provided with toothed wheels, and connected together by an intermediate wheel, 84, motion being imparted to the cylinder 103 by a toothed wheel, 83, which meshes with a similar wheel, 82, constituting one of a train of such wheels 82 74 73 72, which, as before described, are driven by a toothed wheel, 71, upon the shaft of the cutting-cylinder 41. The conveying-tapes 42 run under a roller, 122, which nips, detaches from the web if not completely severed by the cutters, and accelerates the sheets, and return over a roller, 123, and the tapes 52 run under said roller 122, and return over a roller, 124. The tape-rollers 33 35 are geared together by toothed wheels 126 127, and a pinion (not shown) on the roller 35 receives motion through an intermediate wheel, 128, from a toothed wheel, 129, on the shaft of the cutting-cylinder 41; and, since said wheel 129 is larger than the periphery of the said cutting-cylinder 41, it follows that the tapes 42 52 will be moved at a higher surface-speed than that of the cutting-cylinders, thereby causing the rollers 122 124, which may be geared together and driven positively, to operate as a sheet nipping and accelerating device.

The folding mechanism consists of two carriers, 99 130, the former provided with an oscillating sheet-nipping mechanism, and the latter with two sets of grippers, one of which may be rendered inoperative, and with three removable folding or creasing blades. The carrier 99 is of half the size of the carrier 130, and the two, geared together so as to run with uniform speed, are driven by a toothed wheel, 85, which meshes with the wheel 82.

This modification of the apparatus may perform the operation, paragraph A, by adjusting the cutting-blades so that only one—as

10—will operate, separating the nipping-rollers 31 32, and setting the switch 101 in the position shown in Fig. 10. The web will then be severed into large-size sheets, which, separated a distance apart by the nipping-rollers 122 129, will be collected to the desired number upon the accumulating-carrier and delivered in a single body therefrom, as in Fig. 10.

If half-sheets are to be collected for flat delivery, which operation is described in paragraph B, then the second cutter, 11, is adjusted in operative position, and the nipping-rollers 31 32 are moved into surface-contact.

The web will then be divided into half-size sheets, which, separated a distance apart by the nipping-rollers 31 32, will be collected in two separate bodies, each occupying nearly one-half the surface of the carrier, which bodies of sheets may be separately delivered to the fly-frame 121; but in performing this operation the tapes 113 104 and the fly-frame 121 will require to be operated twice as often as in manipulating full-size sheets.

If it is desired to deliver full-size sheets folded, as in the operations described in paragraph E, then one cutter, 10, the nipping-rollers 31 32, and switch 101 are adjusted as in Fig. 9, and the folding or creasing blade 132 is placed in the carrier 130, and the grippers 133 thrown out of action, as in said Fig. 9, or they may be removed.

The web will then be severed into full-size sheets, which will be separated a distance apart by the nipping-rollers 122 124, and each sheet be directed by the switch 101 and conductor 96 to the grippers 134, which will seize the sheet, and convey it around with the carrier 130, releasing it a moment before the folding or creasing blade 132 doubles it upon a central line into the grasp of the nippers 131. Thus grasped, the sheet will be conveyed by its doubled edge under the pressing-roller 137, and delivered to the tapes 138 139, the nippers 131 being opened at the proper time to release their hold, which will convey it out of the apparatus.

If it is desired to deliver half-size sheets folded, both cutters, 10 11, and the nipping-rollers 31 32 are brought into operation. The folding or creasing blades are properly adjusted by removing the blade 132, and inserting the blades 135 136, as in Fig. 11, and throwing the grippers 133 into operation.

The web will then be severed into half-size sheets; each sheet will be advanced a distance by the nipping-rollers 31 32; the first sheet will be seized by the grippers 133, and folded by the blade 136; the second sheet will be seized by the grippers 134 and folded by the blade 135, each sheet being delivered to the tapes 138 139, and carried out of the machine.

The nipping device constituted by the rollers 31 32 may be placed a proper distance from the cutting-cylinders to manipulate sheets one-third the size of the large sheets. In this case the cutting-cylinders must have cutters adapted to properly sever the web, and the

gathering-cylinder will have three points of delivery, as in Figs. 7 and 8.

This accumulating-carrier might be provided with grippers, so as to more positively manipulate the sheets, thus having one set for large-size sheets, as in the before-mentioned Patent No. 191,494, or with two sets of grippers, as in Fig. 12.

In this modification said carrier has one point of reception for the sheets, and three points of delivery for the same, as has been described; and, as it is also provided with folding mechanisms, it becomes a combined accumulating and folding mechanism, as in Figs. 12 and 13, and as in said Patent No. 191,494.

It is here shown as provided with two rotary folders, 107 108, and with two sets of grippers, 3 and 5. One set of these grippers, as 5, is made removable, so that a rotary folder, as 208, may be set to operate in its bearings, and both sets of switches be rendered inactive, as has been described with reference to Fig. 7; and this rotary folder 208, as well as those 107 108, will be provided with actuating mechanisms that may be thrown in and out of action, and otherwise operated, as hereinafter described, and according to the modes set forth in said Patent No. 191,494. In this modification the tapes 42 are returned over one of a pair of folding-rollers, 160 159, which rollers, forming one point of delivery for the sheets, co-operate with the rotary folders when the operation of folding sheets is to be performed, and the tapes 65 and their roller 58 are made to swing as in said Patent No. 191,494.

So modified, the apparatus may operate as hereinbefore described in paragraphs A and B, or as follows:

(I) Divide the web into full-size sheets, and fold the same singly through the folding-rollers 159 160.

(J) Divide the web into half-size sheets, and fold the same singly through the folding-rollers 159 160.

(K) Divide the web into full-size sheets, collect or accumulate two or more such sheets in a single body, and fold the same together through the rollers 159 160.

(L) Divide the web into half-size sheets, collect or accumulate two or more such sheets in two distinct bodies, and fold each of said bodies of sheets through the rollers 159 160.

To perform the operation described in paragraph A, the mechanisms actuating the rotary folders 107 108, grippers 5, and nipping-rollers 31 33 are adjusted so that said mechanism shall not operate, and the tapes 65 are kept in full contact with the carrier 30. The apparatus then operates as before described in said paragraph A, except that the heads of the sheets are herein controlled by the grippers 3.

To perform the operation described in paragraph B, the mechanisms actuating the grippers 3 and 5 and nipping-rollers 31 33 are adjusted so that said grippers and nipping-rollers shall both operate, the rotary folders re-

maining inactive. The apparatus then operates as described in said paragraph B, except that the heads of each respective body of sheets are herein controlled by said grippers 3 and 5.

To perform the operation described in paragraph I, the grippers 5 are removed, and a rotary folder, 208, substituted for them, as in Fig. 13, the rotary folders 107 108 still remaining inactive, and the nipping-rollers 31 33 separated, and the tapes 65 are rocked out of contact with the leading edge of the sheets. Each full sheet then received upon the carrier will be seized by the grippers 3, and doubled by the rotary folder 208 through the rollers 159 160.

To perform the operation described in paragraph J, the grippers 5 are replaced, and the mechanisms actuating them (as well as the rotary folders 107, 108) are brought into operative positions, and the nipping-rollers 31 33 are brought into operation. The small-size sheets then received upon the carrier will be alternately seized by the grippers 3 and 5, and doubled through the rollers 159 160 by the rotary folders 107 108.

To perform the operation described in paragraph K, the mechanisms are adjusted as in the operation described in paragraph I, except that the tapes 65 will be automatically rocked into contact with the carrier when sheets are being accumulated, and out of contact therewith when the same are being folded. The folder 208 must be operated at every second, third, or whatever revolution of the carrier corresponds with the number of sheets to be collected or accumulated, and will fold them together as one body through the rollers 159 160. This mode of operating a single rotary folder is described in the said Patent No. 191,494.

To perform the operation described in paragraph L, the mechanisms are adjusted as in the operation described in paragraph J. The grippers 3 and 5 will then operate successively to seize the incoming sheets, and the rotary folders 107 108 will be operated as described in paragraph K.

It is to be observed that when the web is but partially severed by the cutting-blades, as 10 or 11, or both, that the cutting mechanism must be placed at such a distance from the sheet-nipping device that there shall not be two dividing-cuts in that portion of the web between said nipping device and the cutting mechanism, for the reason that there will be no certainty of action in dividing the web into sheets at the proper points, inasmuch as the web may be separated by the nipping device at the rearmost instead of the foremost dividing-cut in said web. In an apparatus, therefore, wherein the web is but partially severed upon lines dividing it into full and half size sheets, it is necessary to use the half-sheet nipping device; but when the web is completely severed by the cutting mechanism the said half-sheet nipping device is unnecessary, for the reason that the accelerating tapes will

advance each sheet, no matter what its length may be, so as to separate the sheets a distance apart.

The rollers over which tapes pass may be plain or grooved rollers, or be in the form of pulleys set upon a common shaft, as in Fig. 3.

A transverse or a longitudinal pasting apparatus may be combined with this apparatus, as in said Patent No. 191,494, and either mechanism may be adapted to apply paste to the full-size or to the half-size sheets, or to both, as may be desired.

It is obvious that the once-folded sheets delivered from the rollers 49 50, from the rollers 43 44, from the rollers 159 160, or from the tapes 138 139, may be conveyed to other folding mechanisms, as in Sheets 9, 10, 11, and 12 of Patent No. 171,196, granted to S. D. Tucker, December 14, 1875, or as in Sheet 12 of the aforesaid Patent No. 191,494, or as in Sheets 7 and 8 of the aforesaid companion application, filed November 6, 1877; also, that other forms of cutting mechanism, such as may be adjusted to sever the web into different-sized sheets, may be substituted for the cylinders 40 41.

The following is not claimed herein: printing, cutting, web or sheet controlling, and rotary folding mechanisms, nor any combination with each other; but

What is claimed is—

1. The combination, with a sheet-delivering apparatus, consisting of an accumulating or folding mechanism adapted to the manipulation of full and half size sheets, and with a cutting mechanism, of a half-sheet nipping device, interposed between said mechanisms, all substantially as described.

2. The combination, with a sheet-delivering apparatus, consisting of an accumulating or folding mechanism adapted to the manipulation of full and half size sheets, and with a cutting mechanism, of full-sheet and half-sheet nipping devices, substantially as described.

3. An accumulating-carrier provided with means for receiving sheets at one point and for delivering the same at two points, in combination with two fly-frames, all substantially as described.

4. The combination, with an accumulating-carrier provided with two points of delivery, of two switches, for controlling the movements of the sheets at said points of delivery, all substantially as described.

5. An accumulating-carrier provided with means for receiving sheets at one point and for delivering the same at three points, all substantially as described.

6. A folding-blade carrier provided with three folding-blades, one or more of which is removable, all substantially as described.

7. The combination of cutting mechanism, sheet-nipping device, as rollers 31 32, and independent sheet accumulating and folding mechanisms, all substantially as described.

8. The combination, with cutting mechanism, independent sheet accumulating and folding mechanisms, and a movable sheet-directing mechanism, of a sheet-nipping device interposed between said cutting mechanism and accumulating or folding mechanism, all substantially as described.

9. An accumulating-carrier provided with means for receiving sheets at one point, and for delivering the same at three points, in combination with two fly-frames and a folding mechanism, all substantially as described.

10. The combination, with an accumulating-carrier, having two sheet-discharging mechanisms, of tapes interposed between said mechanisms, all substantially as described.

In testimony whereof I have signed my name to this specification in the presence of two subscribing witnesses.

STEPHEN D. TUCKER.

Witnesses:

H. T. MUNSON,
GEO. H. GRAHAM.