

W. B. CHISHOLM.
Rail-Joint.

No. 197,827.

Patented Dec. 4, 1877.

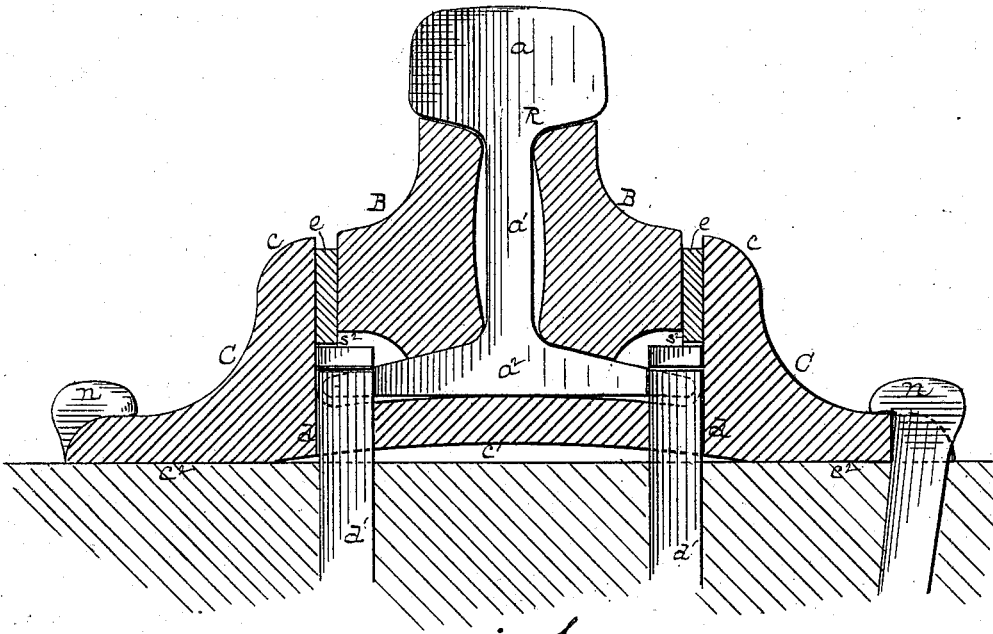

Fig. 1.

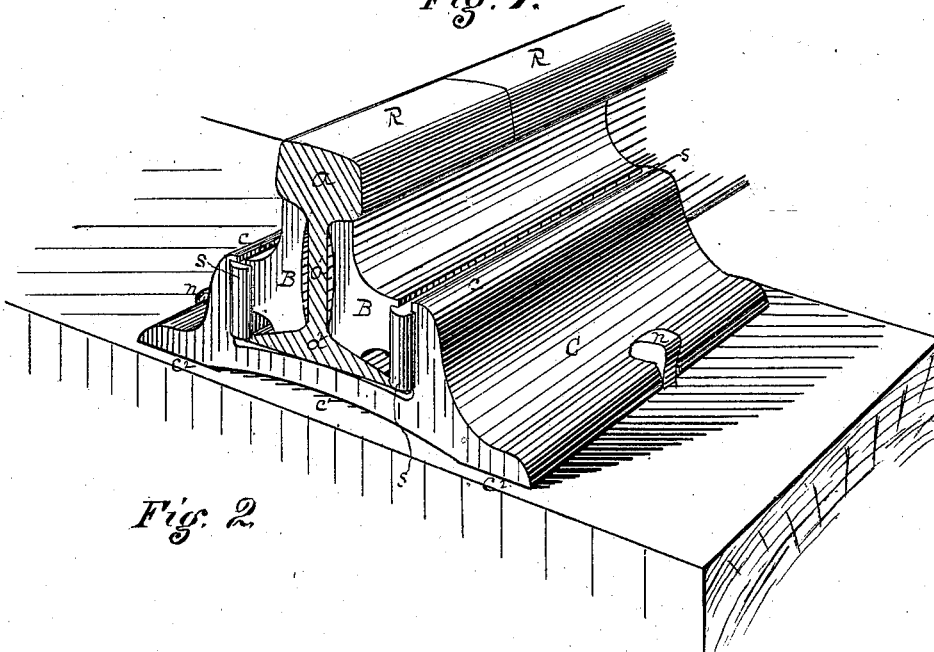

Fig. 2.

Witnesses
Claudius L. Parker.
Am M Conway

Inventor Wilson B. Chisholm,
By Attorney George H. Christy.

UNITED STATES PATENT OFFICE.

WILSON B. CHISHOLM, OF CLEVELAND, OHIO.

IMPROVEMENT IN RAIL-JOINTS.

Specification forming part of Letters Patent No. 197,827, dated December 4, 1877; application filed November 6, 1877.

To all whom it may concern:

Be it known that I, WILSON B. CHISHOLM, of Cleveland, county of Cuyahoga, State of Ohio, have invented or discovered a new and useful Rail-Joint for Railways; and I do hereby declare the following to be a full, clear, concise, and exact description thereof, reference being had to the accompanying drawing, making a part of this specification, in which—like letters indicating like parts—

Figure 1 is a transverse vertical section through the joint in the plane of the end of one of the rails; and Fig. 2 is a view in perspective of the jointing devices, with the rail in section, but made to a smaller scale.

My improved jointing devices consist, first, of a chair made, on its under face, slightly arched or crowning transversely; second, of two side bars which lap the joint of the rails on opposite sides of the web, somewhat like the ordinary fish-bar, but which also have a top and bottom bearing against the under side of the rail-head and the upper face of the rail-base, respectively; and, third, of a pair of keys, which are inserted between the upwardly-projecting flanges of the chair and the bases or outer sides of the side bars.

The contiguous ends of two ordinary rails, which make the joint, are shown at R R, a being the head, a^1 the web, and a^2 the base. The chair is represented at C, and its lips or flanges c , instead of overlapping the base of the rail, as is usual, are made with their inner walls vertical, or so nearly so as to give a good backing or support to the keys e . The chair is preferably made of wrought metal or cast-steel by rolling, and in the process of making its lower face is brought to an arched or crowning form, substantially as represented at c^1 , the outer edges c^2 of the chair forming the ends or bearing-points of the arch. The rail-seat is, also, by preference, made slightly crowning. The amount or degree of curvature is regulated with reference to the function to be performed thereby, which will be presently explained. The side bars B are made preferably by rolling, and of such form that when inserted in the position or place shown in the drawing the upper edge of each will bear against the under side of the rail-head a , the lower edge of each on the upper face of the

rail-base a^2 , at or near its junction with the web, and the outer edge of each will come in convenient relation to the flanges c , with reference to the insertion of keys or wedges e between such flanges and the bars B. These keys or wedges may be of any desired form or construction, such as, when inserted in place, will keep the bars B well up in contact with the head and base of the rail, as described, or so nearly so as to attain wholly or to some useful extent the object of my invention; but the form of keys shown in the drawing is suitable for the purpose. They consist each of a metallic strip of proper width and thickness for occupying the space between the flanges c and the bars B. They are inserted edgewise from above, and are kept in place partly by their own gravity, and partly by the enlarged or upset heads s , formed on their ends, or other suitable stop device adapted to prevent longitudinal motion.

A railway-train passing over a joint thus made will, of course, spring or tend to spring the arch or crown of the chair-bottom downward. The result of this will be to deflect the flanges c toward each other to a corresponding extent, and these, bearing on the keys e , will through them tend to force the bars B forward toward the rails, so that the upper and lower edges of the bars will be forced into a tighter bearing-contact with the head and base of each rail, as above set forth. Hence each end of each rail will be supported by its connection with the contiguous end of the next rail, so that, practically, a solid continuous union will be formed between them. It will also be seen that the heavier the passing load the more solid and firm will this union be.

When the parts are somewhat loosely put together, as will sometimes be done by careless workmen, or become somewhat loose by wear, the bottom of the chair will spring a little more, so as to bring the bars B into bearing-contact as described, and in this respect of taking up the "slack motion," as it is called in machinery, my improved devices are automatic in their operation.

The place and manner of using spikes in connection with this improvement is largely a matter of discretion. I prefer, however, to use outside spikes n , as is common, and also

to punch two spike-holes, *d*, through the chair-bottom in the plane of the meeting of the rails, and one at each edge of the rail-seat. The corners of the rail-bases are then to be notched to a depth and length equal to one-half the size of the shank of the spike. The rails then being in place, a T-headed spike, *d'*, is then driven on each side, so its shank shall occupy the notches in the corners of the rail-bases, and go through the holes *d*, and the T-head of each spike shall project forward and back, and overlap each rail-base sufficiently to steady it in place. Notches *s*² are then cut in the lower edges of the keys *e*, so that the keys may rest on the rail-bases, as in Fig. 2; but the rail-bases and the keys may be notched elsewhere, if so preferred, and the spikes be driven through correspondingly - punched holes, as the manufacturer or user may prefer.

The flanges *c*, as already stated, instead of projecting forward over the edges of the base of the rail, as has heretofore been usual, are vertical or nearly so on their inner faces, and they also extend up, with their upper ends or edges opposite the web of the rail, and high enough, so that on being deflected inward they shall press the interposed bars B into close engagement with both the head and base of the rail.

I claim herein as my invention—

1. In a wrought-metal railway-chair made with a crown or arch on its under face, the upwardly-projecting flanges *c*, having inner walls, vertical or nearly so, and extending up opposite the web of the rail, so as, bearing directly or indirectly against interposed bars B, to force the latter into close engagement with both the base and head of the rail, substantially as set forth.

2. The railway-chair C, having a crowning or arched bottom, *c'*, and upwardly-projecting flanges *c*, in combination, by means of suitably-interposed keys or wedges, with bars B, the upper and lower edges of which engage the head and base of each rail-end, substantially as and for the purposes set forth.

3. The keys *e*, having upset or enlarged ends, in combination with bars B, rails R, and chair C, having a crowning spring-bottom and upwardly-projecting flanges, substantially as set forth.

In testimony whereof I have hereunto set my hand.

WILSON B. CHISHOLM.

Witnesses:

S. H. CHISHOLM,
C. B. BEACH.