

W. MASON.
Locomotive Truck.

No. 197,940.

Patented Dec. 11, 1877.

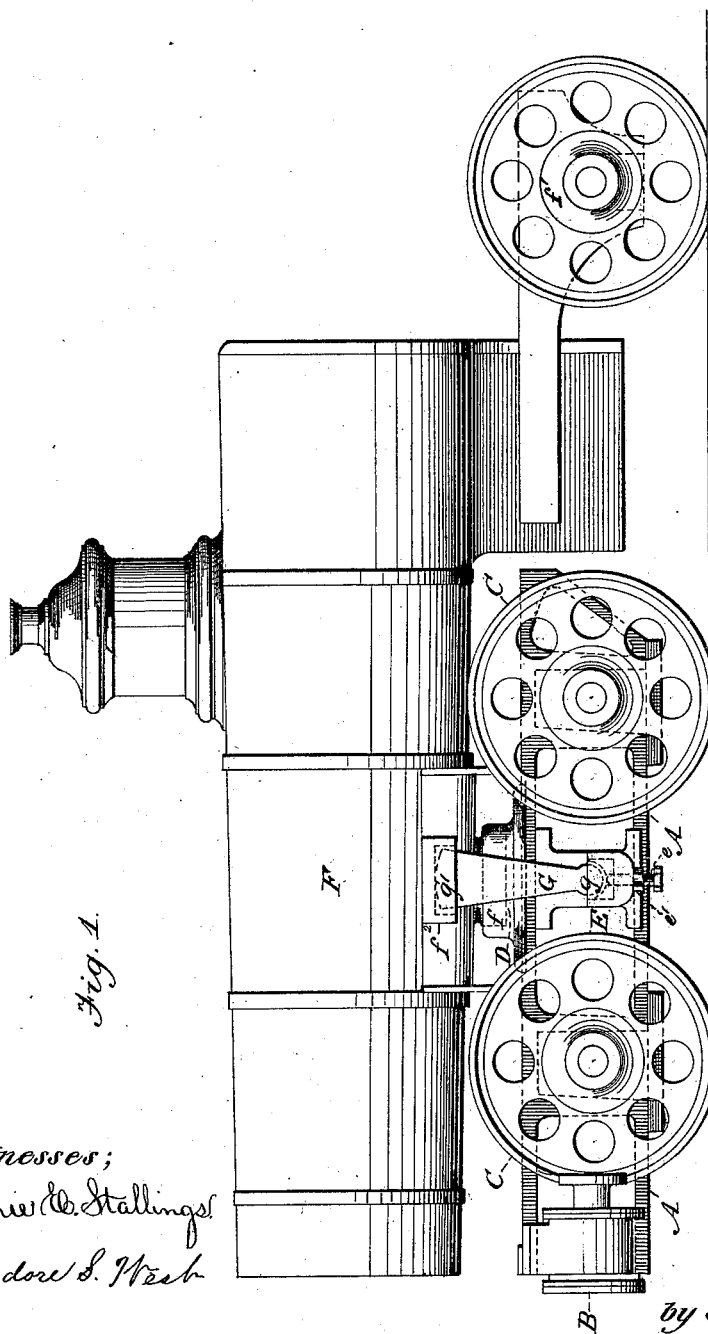

Witnesses;
Mamie C. Stallings
Theodore S. West

Inventor.
W. Mason.
by H. R. Beadle & Co.
Atty.

W. MASON.
Locomotive Truck.

No. 197,940.

Patented Dec. 11, 1877

Fig. 2.

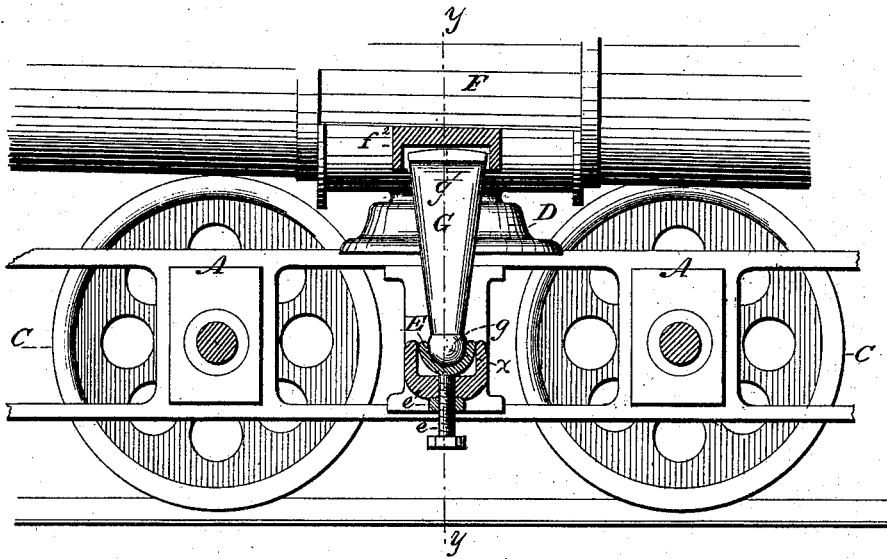

Fig. 4.

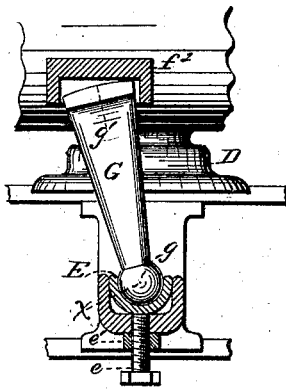

Fig. 3.

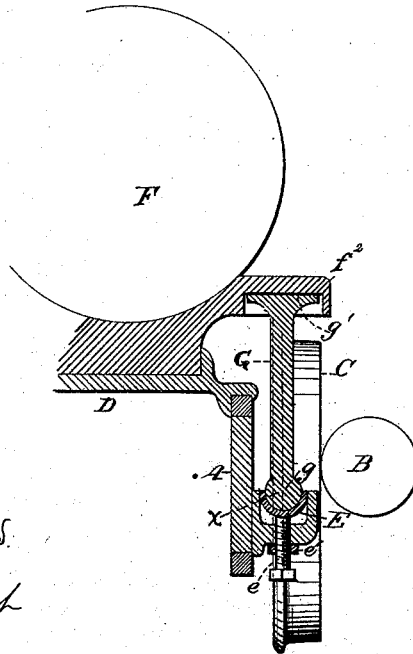
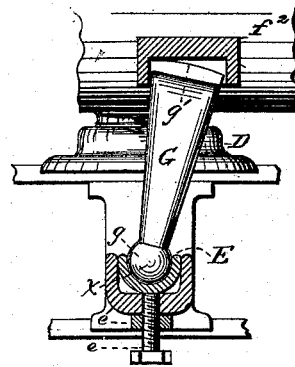

Fig. 5.



WITNESSES:

Wm. C. Stallings
Theodore S. West

INVENTOR:

WM. MASON

BY *H. W. Beadle & Co.*

ATTY S.

UNITED STATES PATENT OFFICE.

WILLIAM MASON, OF TAUNTON, MASSACHUSETTS.

IMPROVEMENT IN LOCOMOTIVE-TRUCKS.

Specification forming part of Letters Patent No. **197,940**, dated December 11, 1877; application filed April 11, 1877.

To all whom it may concern:

Be it known that I, WILLIAM MASON, of Taunton, in the county of Bristol and State of Massachusetts, have invented new and useful Improvements in Locomotive-Engines; and I do hereby declare that the following is a full and exact description of the same, reference being had to the accompanying drawing, and to the letters of reference marked thereon.

Figure 1 represents a side elevation of my invention; Fig. 2, the same, partially in section, to show the bearings of the radial arms; Fig. 3, a transverse section through the line *y y* of Fig. 2; and Figs. 4 and 5, detail views, partly in section, showing the position the radial arms take when the boiler is turned either way upon the truck.

This invention consists, mainly, in the combination, with a locomotive steam-boiler, of a pivoted truck having driving-wheels and steam-cylinders attached thereto, and rigid trailing wheels, the truck being adapted to support the front end of the boiler, and permit a turning movement of the truck relatively to the boiler and the trailing wheels at the rear end.

It further consists of certain details of construction, all of which will be fully described hereinafter.

To enable others skilled in the art to make and use my invention, I will now proceed to describe fully its construction and manner of operation.

A A represent the frame-work of the truck, which may be constructed generally in any proper manner. B B represent the cylinders attached to the truck, which receive steam from the boiler to actuate, through the ordinary or other proper intermediate mechanism, the drive-wheels C C. D represents a central bearing-plate, adapted, in any proper manner, to support the corresponding bearing-plate of the boiler, the construction being such that one may turn freely upon the other in either direction.

Steam from the boilers may be conveyed to the cylinders on the truck, and the exhaust-steam discharged therefrom into the smoke-stack, in any proper manner; but I preferably employ the construction described in my Patents Nos. 156,031 and 177,343.

E represents a socket-bearing, rigidly attached to the truck, which is provided below with a vertical set-screw, *e*, and lock-nut *e'*, the purposes of which will be explained hereinafter. F represents the boiler, of any proper construction, which is provided, forward of its transverse center line, with a bearing-plate, *f*, adapted to rest upon the corresponding bearing-plate of the truck, as shown, and at its rear end with an extended platform, adapted to be supported by the trailing wheels *f¹ f¹*, Fig. 1, as shown. *f² f²* represent socket-bearing plates or flanges projecting from the boiler on each side, in such position as to be directly over the socket-bearing E when the longitudinal center lines of the boiler and truck coincide, as shown in Fig. 2. G represents an intermediate radial bar or brace, provided below with a spherical bearing-surface, *g*, and above with a curved bearing-surface, *g'*, the latter being an arc of a circle struck from the base-point X, Figs. 4 and 5, as a center.

The general operation will be readily understood. Steam is conveyed to the cylinders upon the truck, and the latter being permitted to turn independently of the boiler and trailing wheels, it follows that curves may be easily passed without strain upon the track or engine.

The larger portion of the weight being borne by the truck to which the driving-wheels are attached, the tractive power of the engine is consequently increased.

The purpose of the radial arm or brace is to prevent oscillation of the boiler over its center, and also to take such a portion of its weight as may be necessary to relieve the friction between the bearing-plates, that the truck or bogie may swivel freely. A certain amount of friction is necessary to prevent the truck from acquiring a seesaw motion, while too great an amount would cause the wheels to wear their flanges and cut the rails in turning curves. Through the medium of these arms the friction between the bearing-plates can easily be regulated by means of the screw *e*.

The operation of this radial arm or braces is as follows: When the longitudinal center line of the boiler and truck coincide, the line of support of the brace-bar is through the vertical center line, as shown in Fig. 2, the center

only of the bearing-arc being in contact with the upper socket-block, as shown. When, however, the truck is moved relatively to the boiler, as shown in Figs. 4 and 5, the brace-bar is consequently rocked upon its curved end, so that its bearing-point is changed to that part of the arc whose radius now occupies the central vertical line, the construction being such that in all positions the line of support coincides with one of the radii of the circle of which the arc is part.

Having thus fully described my invention, what I claim as new, and desire to secure by Letters Patent, is—

1. In combination with a locomotive-boiler, a truck pivoted to the boiler, having driving-wheels and cylinders attached thereto, as described, and rigid trailing wheels, substantially as described.

2. In combination with the boiler and a pivoted truck, intermediate adjustable means for determining the friction of the pivoted bearings, substantially as described.

3. In combination with the adjustable socket-bearing E and the rocking brace-bar, the socket-bearing f^2 , as described.

4. The combination of the following elements: the truck A, the boiler F, intermediate bearings D f , and adjustable brace-bars G, for determining the friction of the bearings, substantially as described.

This specification signed and witnessed this 10th day of March, 1877.

WM. MASON.

Witnesses:

J. E. DODGE,
BENJ. DEAN.