

E. S. SMITH.  
Windmill.

No. 197,948.

Patented Dec. 11, 1877

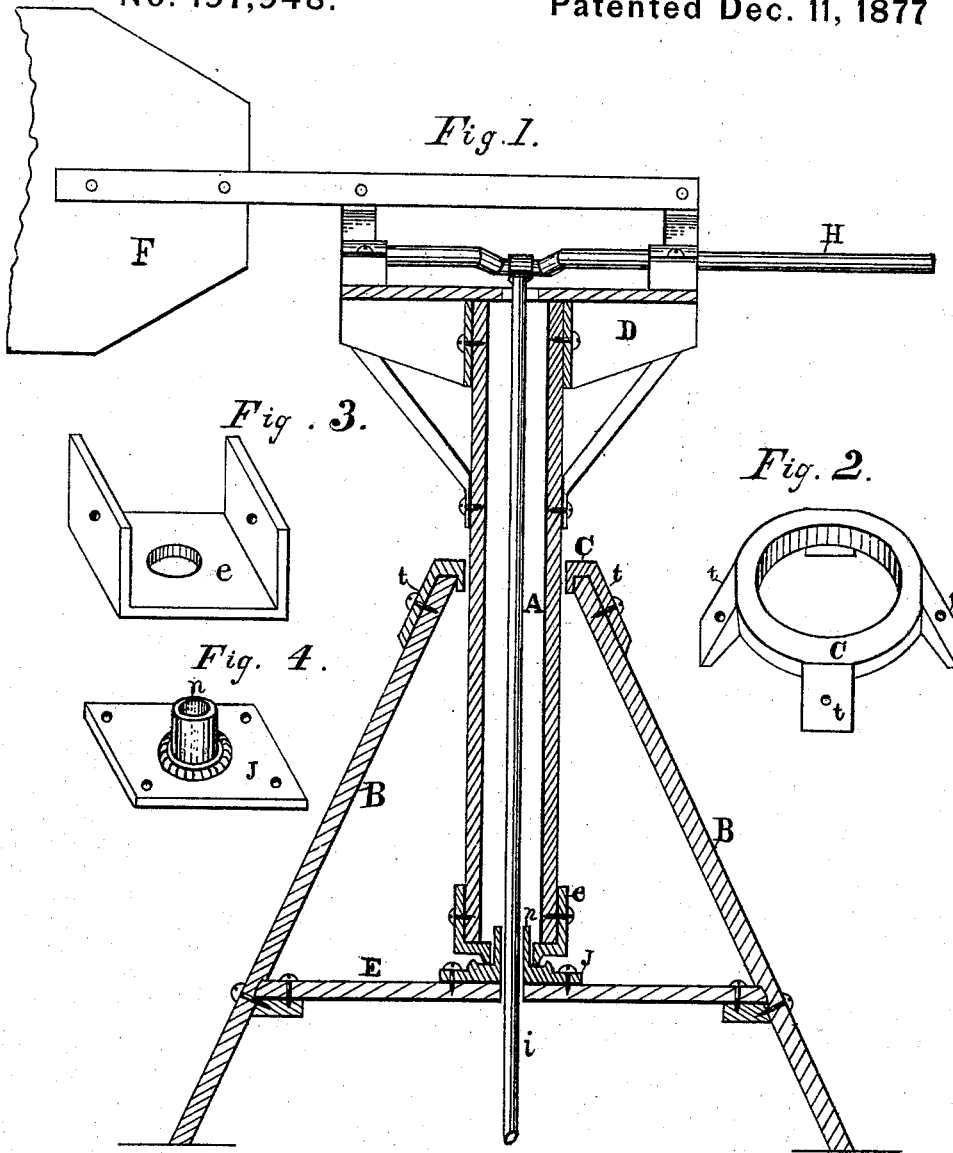

WITNESSES.

J. J. Price  
Wm. J. Price

INVENTOR.

E. S. Smith

# UNITED STATES PATENT OFFICE.

ELIJAH S. SMITH, OF GOOD HOPE, ILLINOIS.

## IMPROVEMENT IN WINDMILLS.

Specification forming part of Letters Patent No. **197,948**, dated December 11, 1877; application filed October 10, 1877.

*To all whom it may concern:*

Be it known that I, ELIJAH S. SMITH, of Good Hope, in the county of McDonough and State of Illinois, have invented new and useful Improvements in Windmills; and I do hereby declare that the following is a full, clear, and exact description thereof, which will enable others skilled in the art to make and use the same, reference being had to the accompanying drawings, forming part of this specification, in which—

Figure 1 is a sectional elevation. Figs. 2, 3, and 4 are detached parts of the same.

My invention consists in the construction of a windmill with a hollow revolving standard; and its novelty consists in the combination of a hollow standard and suitable appliances, whereby the standard is held in a vertical position, and free to be acted upon by the slightest change in the direction of the wind.

In the drawings, A, Fig. 1, represents the standard, to which the T or cross head D is firmly attached and stayed with suitable braces. To this cross-head the vane F is attached, and it is also provided with suitable bearings for the crank-shaft H, to which the pitman *i* is attached. This pitman passes down through the hollow in the standard to the ground, or to where the power is wanted.

B B represent a frame or derrick, composed of four angular legs, firmly attached to the arms or projections *t t t t* in cap C. (See Fig. 2.) Near the lower end of the legs is placed a cross-piece, E, on which the lower end of the standard A rests. In the center of

this cross-piece E is firmly attached a metal plate, J, provided with a tube, *n*, in the center, three or four inches high, (see Fig. 4,) through which the pitman *i* passes.

On the lower end of the standard A is firmly attached a metal plate, *e*, provided with up-turned flanges, (see Fig. 3,) and a hole in the center of sufficient size so that it will go down loosely over the tube *n* and rest on the plate J, making a suitable bearing, and allowing the standard A to turn freely and easily.

The mill is set up for use by passing the standard A through the cap C, and the lower plate *e* passing down over the tube *n* until the standard A rests on the plate J, as shown in Fig. 1.

A suitable wind-wheel is then placed on the crank-shaft H, and with all the bearings properly oiled, the mill is ready for use. The slightest wind acting on the vane F causes the standard A to turn in that direction, keeping the wind-wheel always in the right position.

Having thus fully described my invention, what I claim as new, and desire to secure by Letters Patent, is—

The hollow revolving standard A, provided with the cross or T head D and plate *e*, in combination with the frame or derrick B B, provided with the cap C and plate J, substantially as shown, and for the purpose set forth.

E. S. SMITH.

Witnesses:

T. J. PRICE,  
WM. T. PRICE.