

T. DAVIS.
Globe Valve.

No. 197,967.

Patented Dec. 11, 1877.

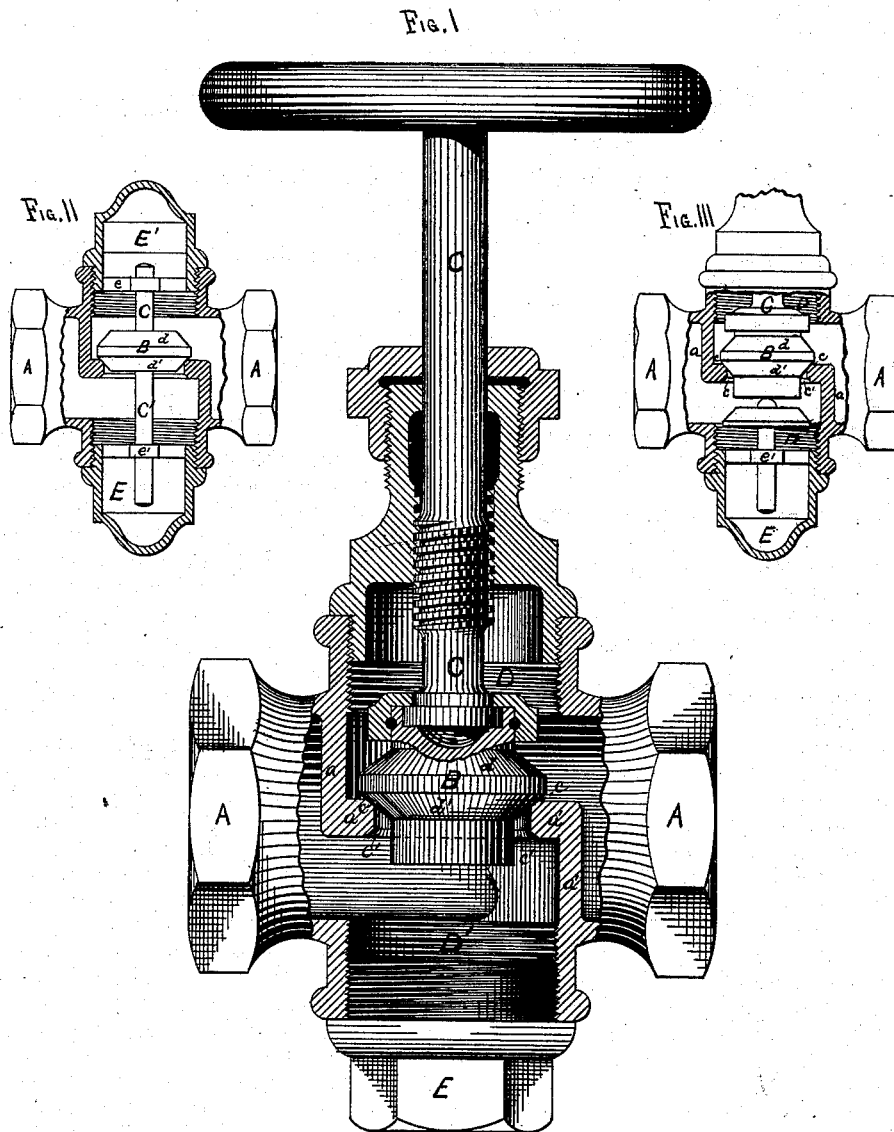

WITNESSES.
C. H. Woodward.
L. M. Starkey

Thomas Davis,
INVENTOR, BY
Louis Feiser & Co.,
Atty's.

UNITED STATES PATENT OFFICE.

THOMAS DAVIS, OF ST. PAUL, MINNESOTA.

IMPROVEMENT IN GLOBE-VALVES.

Specification forming part of Letters Patent No. **197,967**, dated December 11, 1877; application filed October 30, 1877.

To all whom it may concern:

Be it known that I, THOMAS DAVIS, of St. Paul, in the county of Ramsey and State of Minnesota, have invented certain new and useful Improvements in Globe-Valves, which invention is fully set forth in the following specification and accompanying drawings, in which—

Figure I is a sectional elevation of a globe-valve, showing my improvement arranged therein; Figs. II and III, smaller views, showing the manner in which the invention may be applied to a check-valve, &c.

This invention relates to that class of valves known as "globe-valves;" and consists in forming them with a double seat and a double-sided valve, so that when one side is worn out the other can be used.

The invention also consists in forming the casing with two openings, one for the reception of the stuffing-box carrying the valve-stem, and the other for a temporary screw-plug, the stuffing-box and plug being made interchangeable, so that the valve may be reversed, to enable either seat to be used.

A is the casing, and *a a'* the walls, dividing the interior into two compartments in the usual manner, and in which the usual valve-port is formed.

B is the valve; C, the stem; and *c*, the valve-seat, all formed in the usual manner.

In the ordinary valve, where only one seat is used, when it becomes worn past recutting the whole casing is rendered useless; and to avoid this difficulty is the object of my invention.

This I accomplish by forming a second seat, *c'*, upon the opposite side of the valve-port, and forming another opening, *D'*, in the casing, corresponding to the opening *D* in which the stuffing-box is screwed. This second open-

ing will be temporarily filled with a plug, *E*, when not in use.

The valve *B* will be formed with two seats, *d d'*, and will be made reversible upon the stem, so that both sides may be used.

It will be at once apparent that when one seat, *c*, or one side, *d*, of the valve *B* is worn out, the plug *E* and stuffing-box may be removed, the valve *B* reversed upon the stem *C*, and the plug and stuffing-box transposed, and the valve will be as good as new again.

By this means I produce a valve embracing all the features of two separate valves, and at but little more expense than the cost of one.

Fig. II represents the double seat applied to an ordinary check-valve. This consists simply in forming the valve *B* with two seats, *d d'*, and two stems, *C C*, which work in guides *e e'* in the two plugs *E E'*.

Fig. III represents the device as applied to a combined check and stop valve.

I claim—

1. The valve-casing *A*, provided with the two openings *D D'*, in combination with the double-seated valve-port *c c'*, arranged and operating substantially as hereinbefore described.

2. The valve *B*, having the two seats *d d'*, in combination with the casing *A* and division-walls *a a'*, provided with the double-seated valve-port *c c'*, arranged and operating substantially as hereinbefore specified.

In testimony whereof I have hereunto set my hand in the presence of two subscribing witnesses.

THOMAS DAVIS.

Witnesses:

C. N. WOODWARD,
EDWARD ROTERT.