

A. H. WAGNER.  
Grinding-Mill.

No. 197,985.

Patented Dec. 11, 1877.

Fig 1

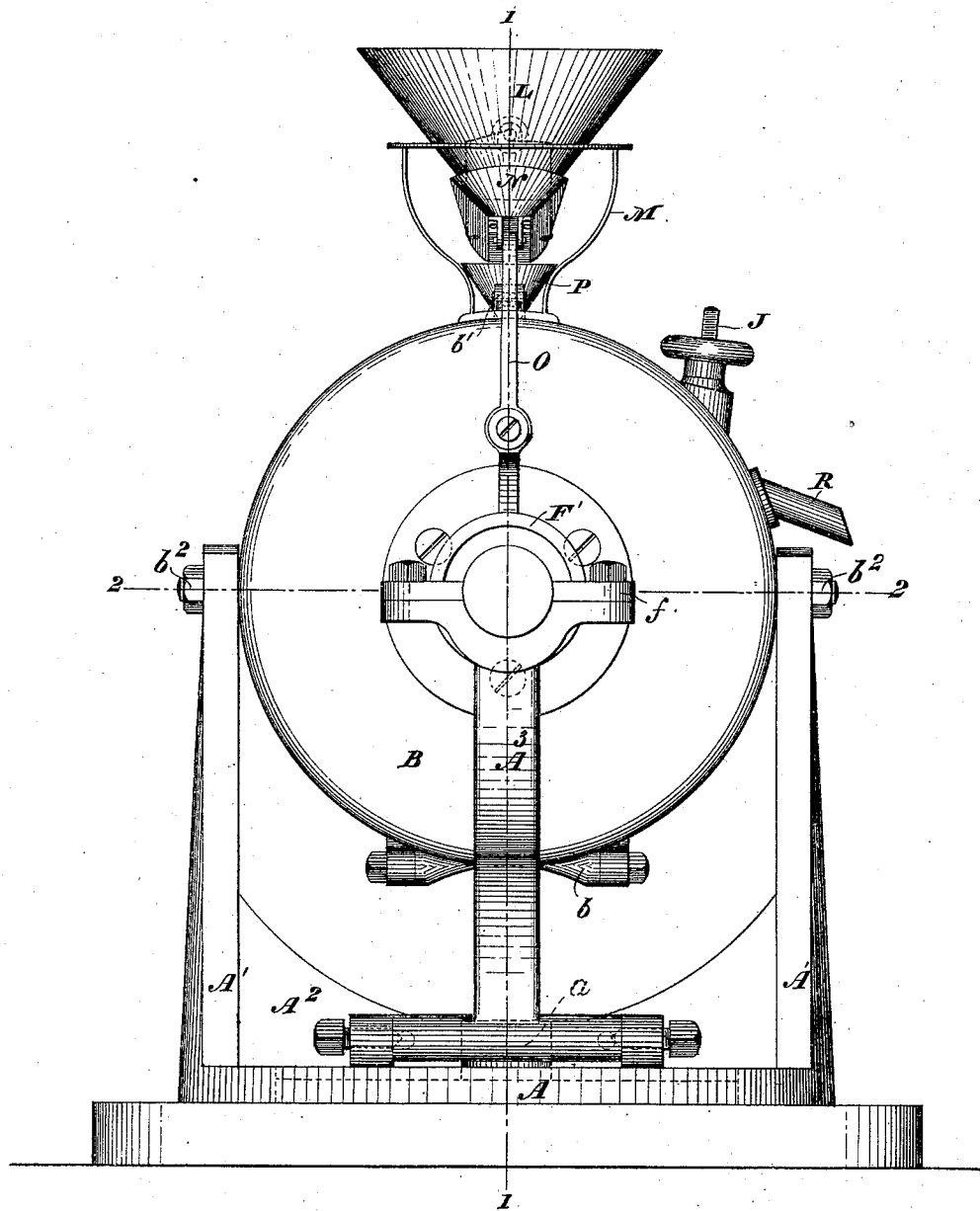

WITNESSES

*Wm a. Skinkle.*  
*Geo. W. Beach.*

INVENTOR

*Ausbert H. Wagner*

By his Attorneys.

*Baldwin, Hopkins & Leiston.*

A. H. WAGNER.  
Grinding-Mill.

No. 197,985.

Patented Dec. 11, 1877.

Fig 2.

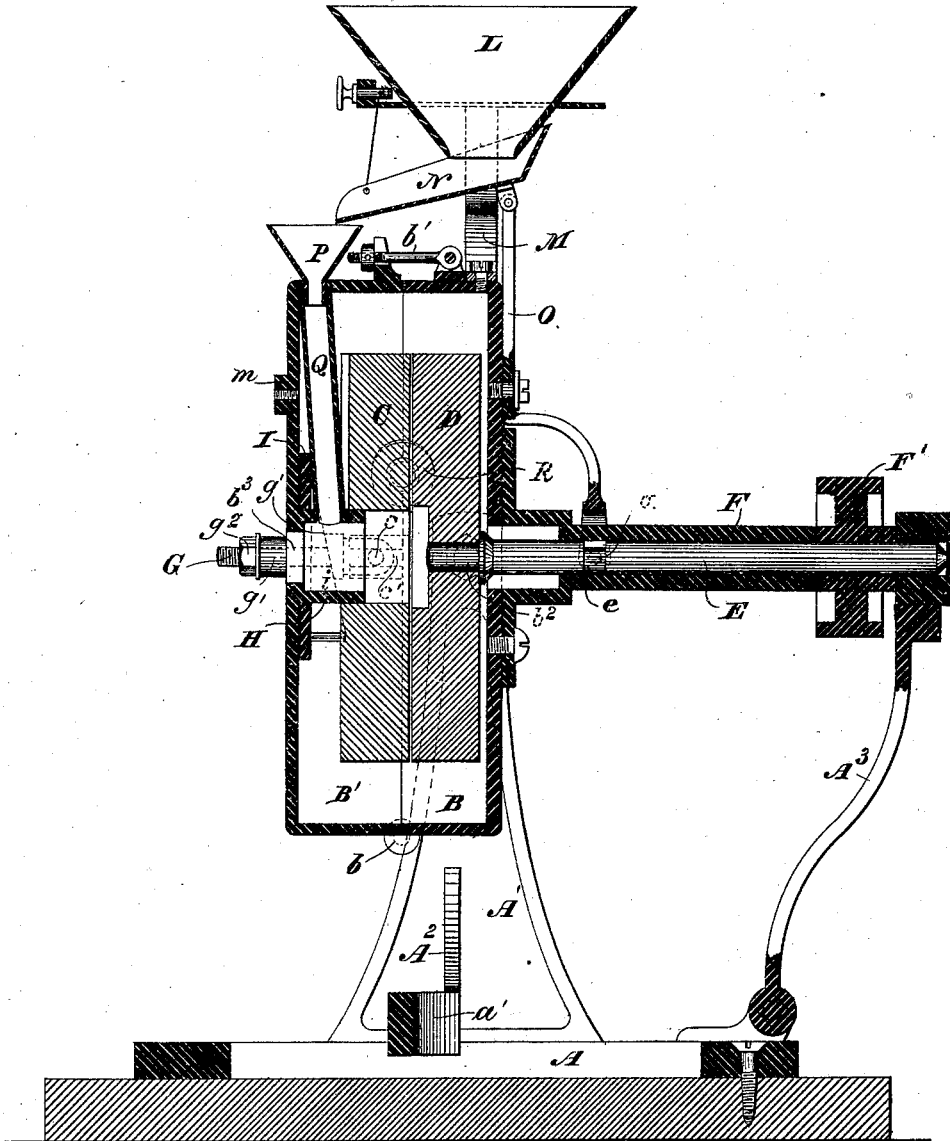

WITNESSES

*Wm. A. Skinkley*  
*Geo. W. Buck*

INVENTOR

*Ausbert. H. Wagner.*

By his Attorneys.

*Baldwin, Hopkins & Peyton.*

A. H. WAGNER.  
Grinding-Mill.

No. 197,985.

Patented Dec. 11, 1877

Fig 3.

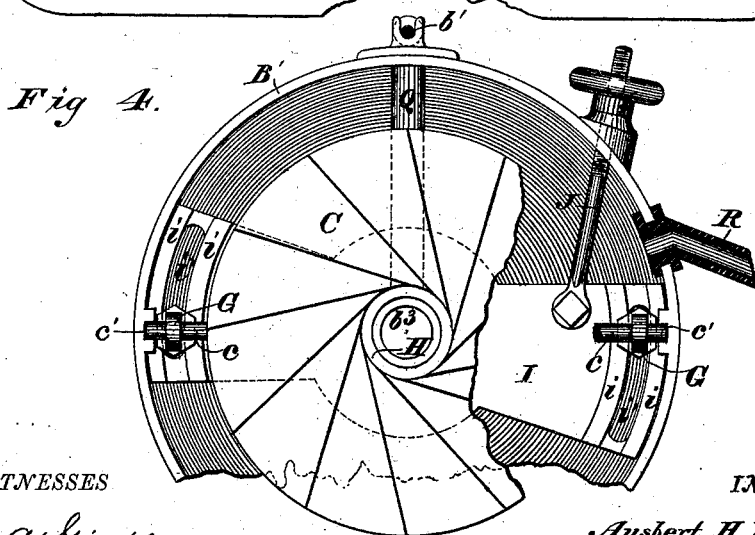
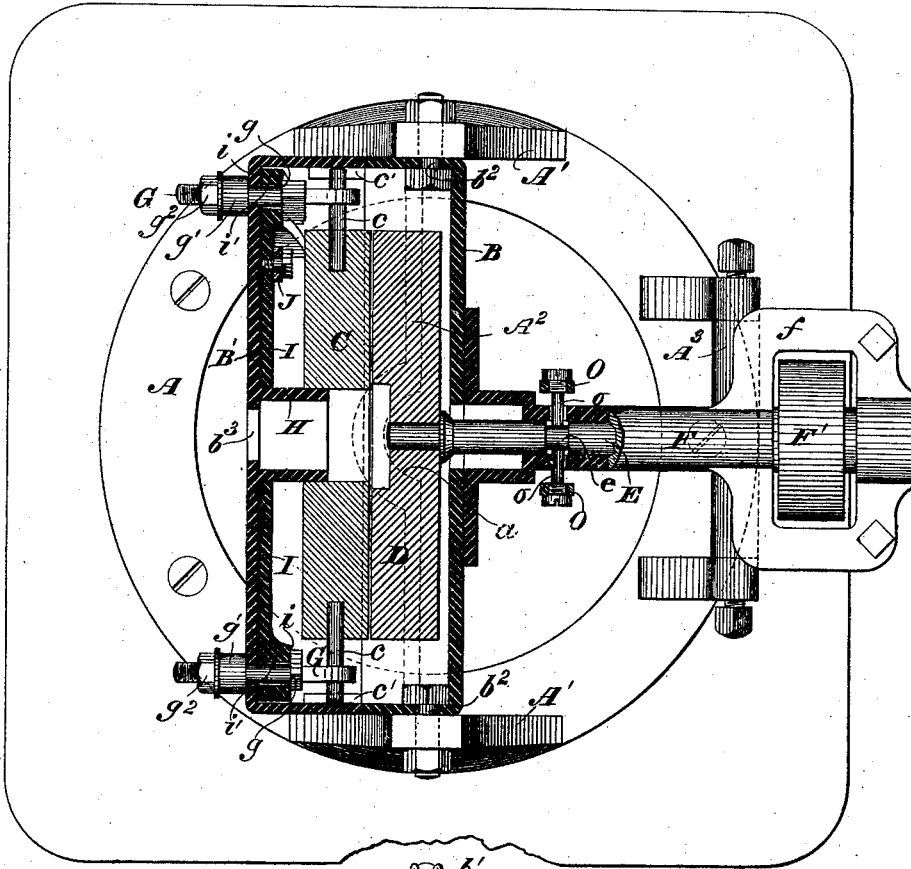

WITNESSES

*Wm A. Skinkley*  
*Geo. W. Beck*

INVENTOR

*Ausbert H. Wagner*

By his Attorneys

*Galwin, Hopkins & Taylor*

A. H. WAGNER.  
Grinding-Mill.

No. 197,985.

Patented Dec. 11, 1877

Fig 5.

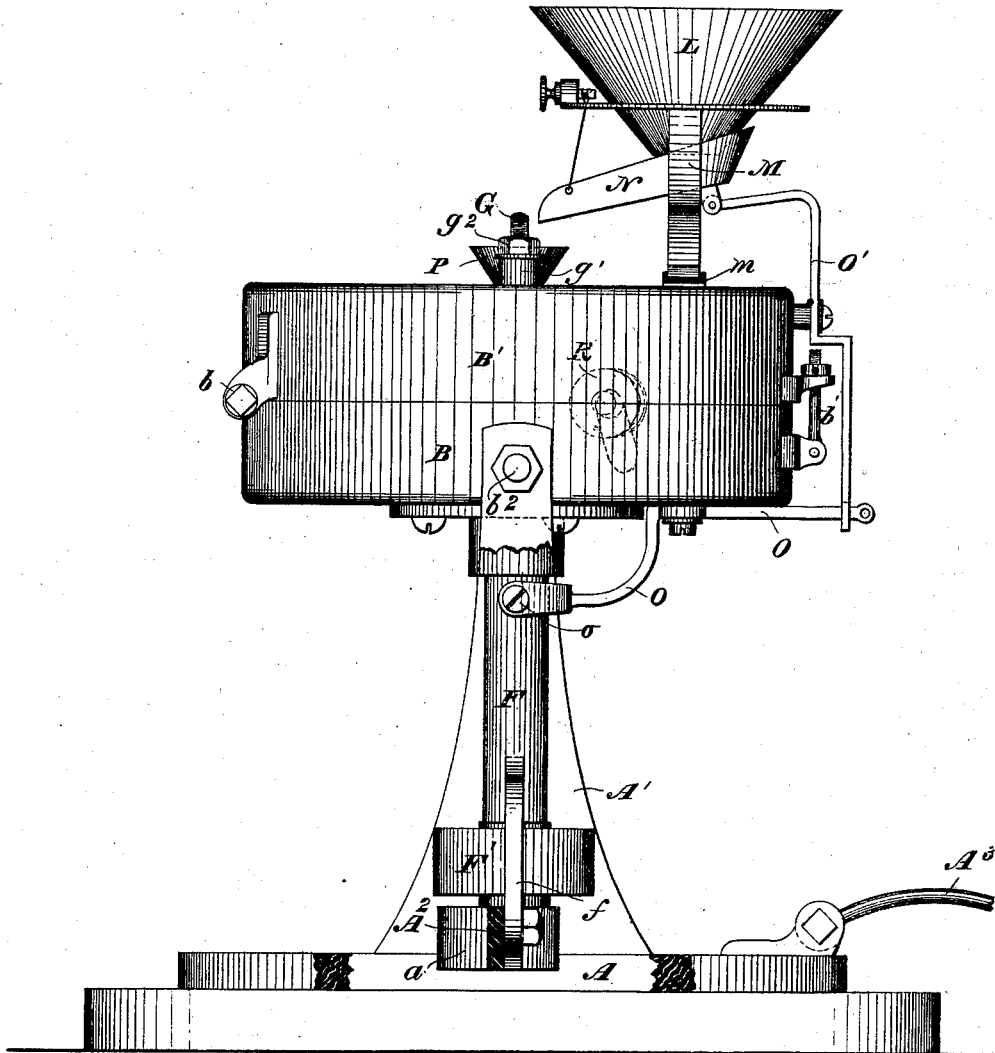

WITNESSES

*Wm A. Skinkle*  
*Geo W. Beck*

INVENTOR

*Ausbert H. Wagner.*

By his Attorneys.

*Galvin, Hopkins & Peyton.*

# UNITED STATES PATENT OFFICE.

AUSBERT H. WAGNER, OF CHICAGO, ILLINOIS, ASSIGNOR TO ANNA G. WAGNER, OF SAME PLACE.

## IMPROVEMENT IN GRINDING-MILLS.

Specification forming part of Letters Patent No. **197,985**, dated December 11, 1877; application filed September 27, 1877.

*To all whom it may concern:*

Be it known that I, AUSBERT H. WAGNER, of Chicago, in the county of Cook and State of Illinois, have invented certain new and useful Improvements in Grinding-Mills, of which the following is a specification:

My invention relates to mills of that class which are capable of being run either as vertical or horizontal mills, and convertible from one into the other.

The object of the first part of my invention is to drive the running-stone steadily and preserve its proper relative position in the casing, whether it be in a vertical or horizontal position, which end I attain by mounting the driving-spindle, the inner end of which is connected rigidly with the stone, in a long pipe-box bearing, rigidly secured to and projecting from the casing, the outer end of which bearing is provided with a flattened recessed portion for the reception of a driving-pulley keyed upon the spindle.

The object of the next part of my invention is to enable the casing and grindstones to be readily converted from a vertical to a horizontal position, or vice versa, which end I attain by means of a main frame, in uprights of which the casing is journaled, said frame being provided with a hinged arm, to support the outer end of the spindle-box when the casing and stones are in a vertical position, and with a rest beneath the suspended casing, to secure the spindle-box when the stones are in a horizontal position.

The object of the next part of my invention is to provide a feeding apparatus, adapted to be placed in different positions on the casing, so as properly to feed the mill when used either as a vertical or horizontal one, which end I attain in the manner and by the means hereinafter specifically set forth.

The next part of my invention relates to the stationary or bed stone. Its object is to allow the stone to yield to accommodate itself to the running stone, and also render it adjustable in relation to said stone, in order to grind fine or coarse, which ends I attain in the manner and by the means hereinafter specifically set forth.

In the accompanying drawings, which show

all my improvements as embodied in one machine in the best way now known to me, Figure 1 is a view of my improved grinding-mill as seen from the rear; Fig. 2, a vertical central section therethrough on the line 1 1 of Fig. 1; Fig. 3, a horizontal section therethrough on the line 2 2 of Fig. 1; Fig. 4, a top or plan view of the bed-stone and its adjusting device, part of the stone being broken away to show the mechanism beneath; and Fig. 5 represents a view in elevation, partly in section, of my improvements converted into a mill the faces of the stones of which are in a plane substantially horizontal, all the preceding figures representing a mill in which the faces of the stones are in a vertical plane.

The main frame A, which is preferably of cast-iron, is provided with two uprights or standards, A<sup>1</sup>, a cross-piece, A<sup>2</sup>, and with a hinged arm or prop, A<sup>3</sup>.

The casing of the mill is divided circumferentially into two sections, B B', hinged together at *b*, and adapted, when closed, to be locked by the swinging bolt and thumb-nut *b*<sup>1</sup>. The casing is suspended by trunnions or journals *b*<sup>2</sup> projecting from the periphery of section B, which have their bearings in suitable boxes in the upper ends of the uprights A<sup>1</sup>, by which means the casing and grindstones mounted therein can turn freely.

The stationary or bed stone C of the mill is supported in section B' of the casing by its adjusting mechanism, and the running stone D is supported in section B by its driving spindle or shaft E, on the end of which it is firmly keyed. This spindle is mounted in a long pipe-box bearing, F, rigidly secured to and projecting from the section B, which bearing is provided near its outer end with a flattened recessed portion, *f*, across which recess the spindle extends, and has its extreme end journaled in a continuation of the tubular portion of the pipe-bearing. A driving-pulley, F', keyed upon the spindle is mounted in the recess *f*, thereby preventing endwise movement of the spindle in its bearing, and enabling me to drive the running stone steadily, and preserve its relative position in the casing.

The inner end of the pipe-bearing, where it

is rigidly connected to the casing just back of the running stone, is preferably enlarged for the reception of a bushing for this end of the spindle.

The bed-stone C is hung upon pivots *c*, which have their bearings in adjustable eyebolts G, the ends of the pivots, after passing through the bolts, extending into grooves or guide-slots *c'* formed in the casing. A hollow central hub or bushing, H, extending from or forming part of the casing, projects a short distance into the eye of the stone, and forms a central support therefor, without, however, interfering with its yielding capacity on its pivots.

The eyebolts G are provided with inclines or cam-surfaces *g*, corresponding with similar surfaces or flanges *i* on a plate, I, mounted in the casing, and turning around the central hub or bushing H beneath the stone. The shanks of the bolts pass through slots *i'* in the turning-plate between the inclined flanges, and through apertures in the casing, and are provided on the outside of the casing with springs or washers *g'*, preferably of rubber, which are confined in place and their tension regulated by screw-nuts *g''*. The plate I is turned upon its axis, to cause its inclines to act upon those of the bolts, in order to adjust the stone, by means of a screw-rod, J, pivoted to the plate, and projecting through the casing, upon the threads of which rod, outside the casing, is placed a suitable thumb wheel or crank.

By the rotation of this wheel upon the rod J, and against the casing, the cam-plate I is turned upon its axis, causing its inclines to ride under the inclined surfaces of the bolts, forcing them inward against the tension of their springs or washers, and adjusting the stone, the springs serving to retain the bolts steadily and firmly in their adjusted position.

It will thus be seen that the bed-stone can be adjusted in relation to the running stone with the greatest accuracy, and from the outside of the casing, in a convenient manner, whereby I am enabled to grind fine or coarse, at pleasure.

The feeding apparatus consists of a hopper, L, supported by a bracket-frame, M, detachably secured to the casing by any suitable means. Beneath the hopper is a shoe, N, pivoted upon the end of a pivoted, forked, vibrating lever, O, the forks of which extend upon opposite sides of the pipe-box bearing, and are provided with pins *o*, which pass through apertures in said bearing, and are operated upon by a cam-surface, *e*, on the driving-spindle E, by which means the shoe is given a shaking motion for a well-known purpose. The shoe empties into a funnel, P, inserted in the mouth of the feed-pipe Q, leading to the hub or bushing H and eye of the stone.

The feed is regulated by adjusting the inclination of the shoe relatively to the funnel in a well-known way.

To convert the mill from a vertical position,

as shown in Figs. 1 to 4, inclusive, of the drawings, into one in which the faces of the stones will lie in a horizontal plane, as in Fig. 5, it is only necessary to remove the supporting arm or prop A<sup>3</sup> from under the outer end of the spindle-bearing, and bring said end, which is allowed by the casing turning upon its journals, down into the recess or rest *a* in the cross-piece A<sup>2</sup> of the main frame, where it may be secured by the same means that held it to the prop, shown in the present instance as consisting of two set-screws. Then detach the hopper-frame from its position upon the circumferential periphery of the casing, and attach it to the curved plate *m* upon the now upper side of the casing, and insert the funnel into the opening *b*<sup>3</sup> in the casing directly above the hub or bushing H, and leading to the eye of the stone. This transfer of the feeding apparatus necessitates the employment of an additional vibrating lever, O', to shake the shoe, one end of this secondary lever being connected with the forked lever O, and the other pivoted to and supporting the rear end of the shoe.

The issuing spout or nozzle R is secured between the sections of the casing in such a manner that it can be turned to accommodate the changes in position of the casing and stones.

When the mill is in a horizontal position, the sections of the casing may be opened and laid back for conveniently dressing the faces of the stones.

The many advantages of my improvements will be appreciated by those skilled in the art.

I claim as my invention—

1. The combination, substantially as hereinbefore set forth, in a convertible grinding-mill, of the frame, the casing surrounding the stones journaled therein, the long pipe-box bearing rigidly secured to the casing and provided at its outer end with a recessed portion for the reception of a driving-pulley, the spindle mounted in said bearing and driven by the pulley, and the running stone rigidly fixed upon the inner end of the spindle, whereby the stone runs steadily and preserves its proper relative position in the casing, whether the driving-shaft is secured in a vertical or horizontal position in the frame.

2. A cast-metal main frame for convertible grinding-mills, constructed substantially as described, provided with a hinged arm or prop adapted to support the driving-shaft of the mill in a horizontal position.

3. The combination, substantially as hereinbefore set forth, of the main frame provided with the cross-piece A<sup>2</sup> and arm or prop A<sup>3</sup>, the casing in which the stones are mounted journaled in said frame, and the driving-shaft, whereby the casing may be rocked upon its journals to convert the mill from a horizontal to a vertical one, or vice versa, and the shaft be securely held in either position.

4. The combination, substantially as hereinbefore set forth, of the casing, hung upon trun-

nions and provided with two feed-openings, with a detachable feeding apparatus adapted to be secured to the casing to feed the mill from either opening.

5. The combination, substantially as hereinbefore set forth, of the casing, the bed-stone pivoted in adjustable eyebolts working there-through, the turning cam-plate mounted in the casing and acting upon the bolts, the springs or washers encircling the bolts outside the

casing, and the rod for operating the turning-plate to adjust the stone, whereby the stone may be adjusted toward or from the running stone, and is free to yield to conform thereto.

In testimony whereof I have hereunto subscribed my name.

AUSBERT H. WAGNER.

Witnesses:

W. H. GREGORY,  
WM. J. PEYTON.