

C. F. & E. E. WHIPPLE.
Draft-Attachment for Wagons.

No. 197,986.

Patented Dec. 11, 1877.

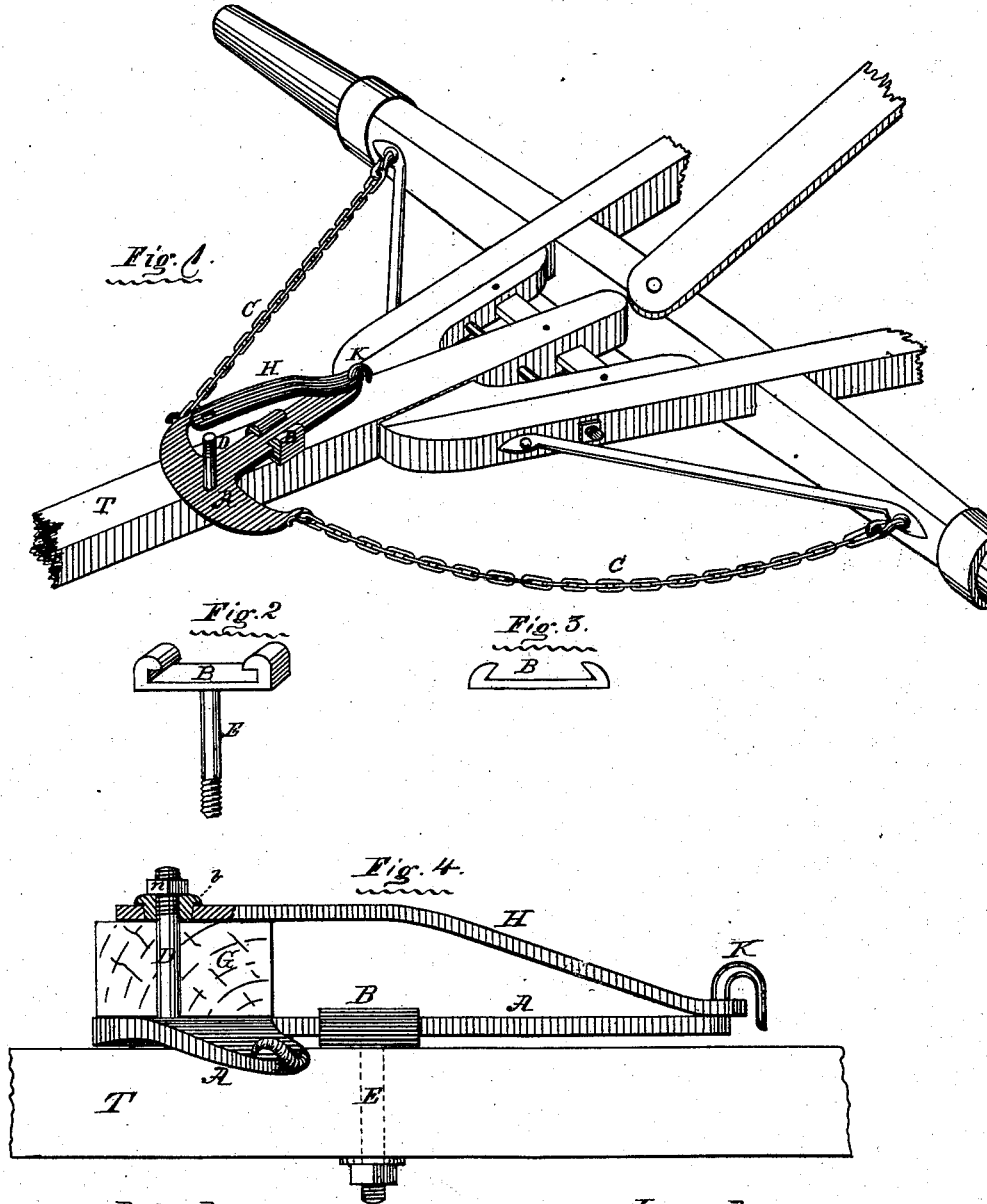

Attest.
Chas. H. Tuqueow,
J. V. Meador

Inventors:
Clarence F. Whipple
Effinger E. Whipple
By W. E. Dayton Atty.

UNITED STATES PATENT OFFICE.

CLARENCE F. WHIPPLE AND EFFINGER E. WHIPPLE, OF CHICAGO, ILL.

IMPROVEMENT IN DRAFT ATTACHMENTS FOR WAGONS.

Specification forming part of Letters Patent No. **197,986**, dated December 11, 1877; application filed May 8, 1877.

To all whom it may concern:

Be it known that we, CLARENCE F. WHIPPLE and EFFINGER E. WHIPPLE, both of Chicago, Illinois, have invented a new and useful Improvement in Draft Attachments for Wagons, Mowing-Machines, and other vehicles and implements, of which the following is a specification:

Our invention relates to devices for connecting draft-equalizing draw-plates to wagon and implement tongues, and for securing the hammer-strap to the plate.

It consists, first, in securing the draw-plate to the tongue by means of a bolt having a wide head within folding flanges, forming an open eye or slot, within which the shank of the draw-plate is held and guided, permitting to the plate both a longitudinal movement within the head, and a rotary or axial movement about the shank of the bolt, as more fully described below; and, second, in connecting the hammer-strap to the draw-plate at its rear end by means of a hook solid with the plate, with the objects of greater permanence, simplicity, and cheapness.

In the accompanying drawings, which form a part of this specification, A is a T-shaped draw-plate, with hooks at the extremities of the arms for the attachment of connecting-chains C C. B is a head, solid with or secured to the bolt E, provided with a retaining-slot or open eye, adapted to receive and retain, while allowing free movement to, the shank of the plate A, and secured loosely to the tongue T by the bolt E. C C are flexible connections, joining the plate A to the vehicle. H is the hammer-strap, provided with an eye fitted to the hook K, which is solid with the plate A. G is the double-tree or evener.

Figure 1 shows the draw-plate applied to a wagon. Fig. 2 shows the slotted head B and bolt E detached from other parts. Fig. 3 shows an equivalent form of the head B, and Fig. 4 is a side view of the attachment with all parts except the chains C C in place.

In applying the attachment to a wagon, the head B is secured to the tongue, as shown in Fig. 4. The draw-plate A, with hammer-strap hooked thereon, is slid into the head B, and the chains C C connected to the front axle near the wheels, as seen in Fig. 1. These

chains should be of such length as, when taut, to hold the plate well back in the head. The double-tree is then put in place and secured by the hammer-strap and nut *n*. Draft being applied, the chains C C will, together and equally, receive the entire strain of the load until one or the other front wheel encounters an obstacle. When this occurs the obstructed wheel is retarded, the tongue begins to swing in the direction of the retarded wheel, the plate A slides backward slightly within the head B, and rotates somewhat on E toward and slackening the chain opposite the obstructed wheel, leaving the entire draft upon the retarded end of the axle. The effect is to greatly reduce the force otherwise necessary to override the obstruction and to diminish the swaying of the tongue.

This prompt diversion of the draft is possible only when the plate A has the compound movement described and permitted by the slotted head B and bolt E.

In applying the attachment to a mowing-machine or other implement without a bed-piece or other suitable places of connection for the chains C C, a cross-bar may be secured to the tongue back of the plate, or other provision may be made for this purpose.

When the hammer-strap is connected to the draw-plate by the solid hook K, it is necessary to provide for its free passage over the top of the bolt D, and at the same time for a direct bearing against the bolt when the strap is lowered to its proper place. To this end, as seen in Fig. 4, the hole in the strap is made larger than the bolt, and when the strap is down the bush *b*, fitting the bolt and the hole in the hammer-strap, and also serving as a washer, is put on under the nut *n*. In this case D is rigid with A; but D may be so secured to A as to tilt back and enter and follow the hole in the strap, and have a bearing and support from H at any point desired without the aid of *b*.

The hook K should be long enough to prevent the removal of the hammer-strap when the plate is attached to the tongue.

Having thus described our invention, what we claim, and desire to secure by Letters Patent, is—

1. In combination with the draw-plate and

connecting-chains of a draft attachment, the bolt E, with its slotted head B, adapted to receive the shank of the draw-plate, and to allow it both a longitudinal and an axial movement upon the tongue, substantially as described, and for the purposes set forth.

2. In a draw-plate of a draft attachment, the strap-hook K, solid with the draw-plate, fitted to the eye of the hammer-strap, substantially as described.

3. In combination with a draw-plate, A, having a solid strap-hook, K, evener-bolt D, and hammer-strap H, the bushing b, substantially as and for the purpose described.

CLARENCE F. WHIPPLE.
EFFINGER E. WHIPPLE.

Witnesses:

M. E. DAYTON,
CHAS. GARDNER.