

E. C DAVEY.  
Anti-Friction Journal-Box.

No. 198,001.

Patented Dec. 11, 1877.

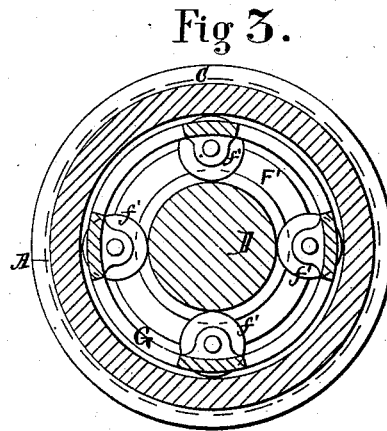
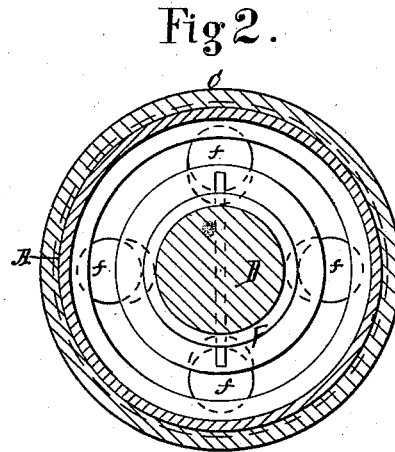
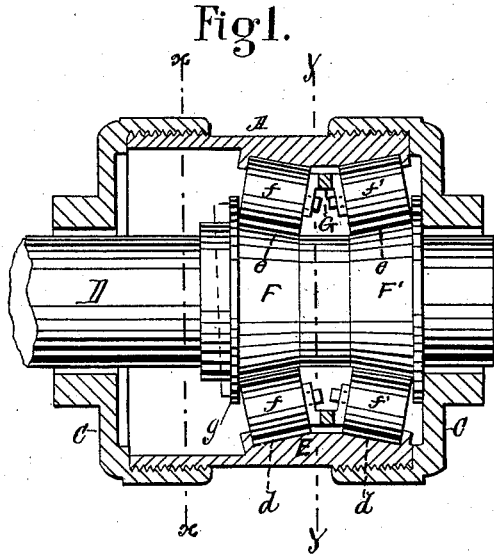

*Witnesses*

*N. Cortes*

*A. H. Sherburne*

*Inventor*

*Elijah C. Davey*  
*By* *Gidley & Sherburne*  
*Attys*

# UNITED STATES PATENT OFFICE.

ELIJAH C. DAVEY, OF BATAVIA, ILLINOIS.

## IMPROVEMENT IN ANTI-FRICTION JOURNAL-BOXES.

Specification forming part of Letters Patent No. **198,001**, dated December 11, 1877; application filed June 9, 1877.

*To all whom it may concern:*

Be it known that I, ELIJAH C. DAVEY, of Batavia, in the county of Kane and State of Illinois, have invented new and useful Improvements in Anti-Friction Journal-Boxes; and I do hereby declare the following to be a full, clear, and exact description thereof, which will enable others skilled in the art to which my invention appertains to make and use the same, reference being had to the accompanying drawing, forming part of this specification, in which—

Figure 1 represents a longitudinal central section of a journal-box embodying my invention. Fig. 2 represents a transverse section of the same, showing the parts which are at the right of the line *x x* drawn across Fig. 1; and Fig. 3 is a like section, showing the parts which are at the right of the line *y y*.

Like letters of reference indicate like parts.

The object of my invention is to so construct a journal-box as to reduce the friction of the journal, and thereby lessen the amount of power required to rotate the journal; and to that end my invention consists in the construction and arrangement of the several parts as hereinafter more fully described and claimed.

In the drawing I have shown a journal-box designed to be used upon a stationary journal, supporting a wheel revolving upon the journal, and I will proceed to describe such construction; but I do not intend to limit myself to stationary journals, as the box may be so constructed as to admit of being secured in a fixed position so as to allow the journal to revolve.

A represents a cylindrical case forming the body of the box, which may be made of any suitable cast or wrought metal, and is provided at each end with an external screw-thread, as shown in Fig. 1. C C are metal caps, which are screw-threaded internally to fit the end of the case A, and each is provided at its center with an opening, through which the journal D loosely passes. The case A is provided internally with an annular rim, E, located near the end of the case, and projecting inward toward the center thereof. The

said rim may be formed separately, and secured within the case, or it may be formed as a part of the wall of the case, and is beveled on its inner surface outward from a point near its center, so as to form two inclined faces, *d d*, as shown in Fig. 1. F F' are annular collars, which are keyed or otherwise secured upon the journal D, and each of which is beveled toward each other, so as to form angular faces *e e*, the planes of which are parallel with the planes of the inclined faces *d d* of the rim E. G is an annular ring, which is loosely fitted into the case A between the collars F F', and is so arranged as to freely revolve within the case. Journalled to each edge of the ring G is a series of anti-friction wheels, *f f'*, which extend into the space between and fit against the respective annular faces on the collars and the corresponding inclined faces on the rims E, as shown in Fig. 1, and are so arranged as to freely revolve on their respective journals by their frictional contact with the angular faces on the collars. The anti-friction wheels *f f'* are also slightly beveled, so as to correspond with the angular faces of the collars and rim.

Each of the collars is provided on its outer edge with an inwardly-projecting flange, *g*, which bears against the outer ends of the anti-friction wheels *f f'*, by which means the said wheels are prevented from moving longitudinally on their journals.

The object of arranging the angular faces on the collars so as to incline toward each other is to prevent a longitudinal movement of the journal D.

Having thus described my invention, what I claim as new, and desire to secure by Letters Patent, is—

The combination, with the rim E, having the inclined faces *d d*, and collars F F', provided with the angular faces *e e*, of the ring G, and series of anti-friction wheels *f f'*, substantially as and for the purpose specified.

ELIJAH C. DAVEY.

Witnesses:

N. C. GRIDLEY,  
N. H. SHERBURNE.