

J. HEWITT.  
Locomotive Spark-Arrester.

No. 198,110:

Patented Dec. 11, 1877

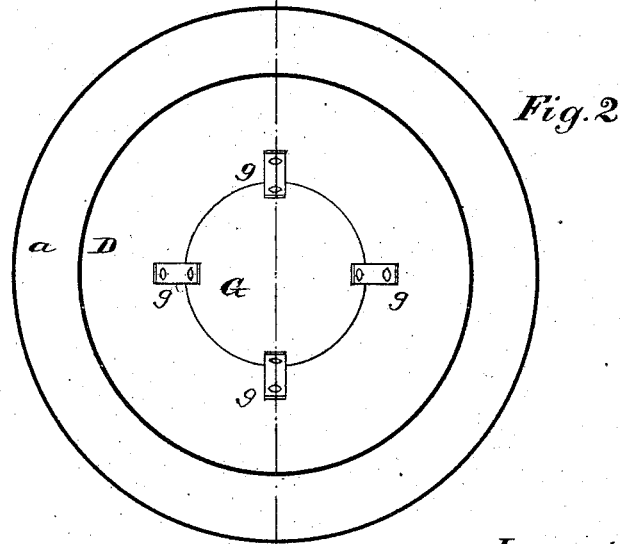
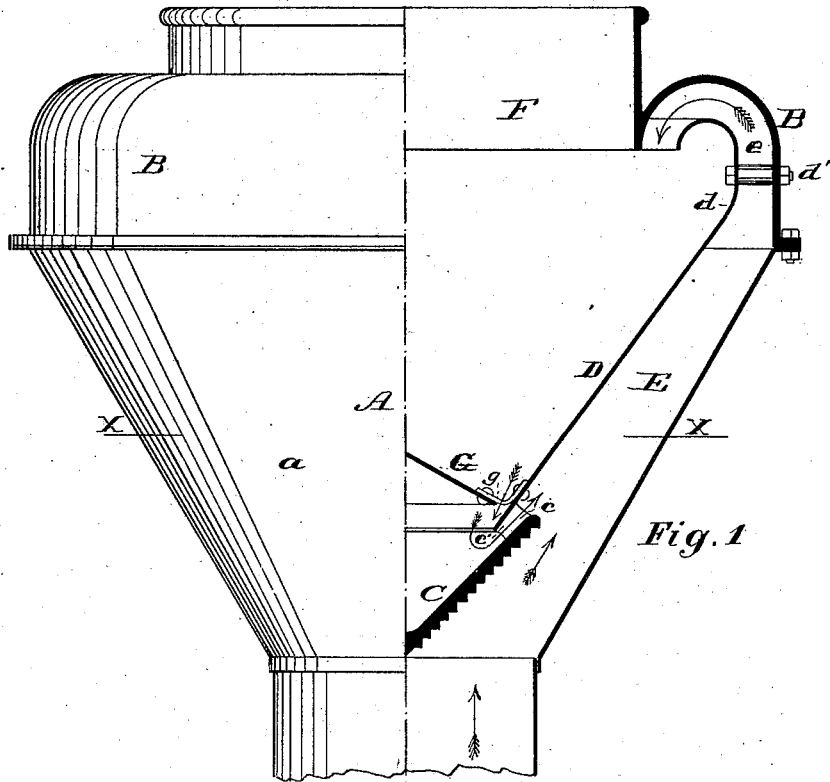

Witnesses,  
*Heriman Guly*  
Chas. S. Moody.

Inventor,  
*John Hewitt*

# UNITED STATES PATENT OFFICE.

JOHN HEWITT, OF ST. LOUIS, MISSOURI.

## IMPROVEMENT IN LOCOMOTIVE SPARK-ARRESTERS.

Specification forming part of Letters Patent No. **198,110**, dated December 11, 1877; application filed October 8, 1877.

*To all whom it may concern:*

Be it known that I, JOHN HEWITT, of St. Louis, Missouri, have made a new and useful Improvement in Locomotive Spark-Arresters, of which the following is a full, clear, and exact description, reference being had to the annexed drawings, making part of this specification, in which—

Figure 1 is an elevation, partly in section, of a smoke-stack embodying the improvement; and Fig. 2, a horizontal section taken on the line *x x* of Fig. 1.

Similar letters refer to similar parts.

Attempts have heretofore been made, in the construction of locomotive-stacks, to pulverize and extinguish the sparks before their issue from the stack; but the constructions referred to, in addition to being complicated and expensive, have generally proved unreliable.

The present invention relates to an improved means for accomplishing the object referred to.

Referring to the annexed drawings, A represents the stack of a locomotive, enlarged at its upper end *a*, in the usual manner. A deflector, B, forms an extension to the shell *a*, extending at first upward therefrom, and then curving inward, and then downward, substantially as shown in Fig. 1. C and D represent, respectively, two hollow cones (so called) arranged one above the other centrally within the stack and pointing downward.

Their form and position may be more particularly described as follows: The cone C is conical in outline, and is arranged so that its apex is at the level, or thereabout, of the commencement of the enlargement *a* of the stack, and the body of the cone extending thence upward into the part *a*.

The cone D is truncated in its general form, and is arranged so that its lower end is within the upper end of the cone C, thereby forming an annular flue, *c*. It extends thence upward (forming, with the shell *a*, the flue E) above the part *a* until it is opposite the lower part of the deflector B, and at this point *d* it is considerably larger in diameter than the mouth F of the stack. Thence the cone D extends upward parallel with the deflector, and to the level of the lower end of

the mouth F; thence, following the curve of the deflector, it curves upward, inward, and downward to the level of the lower end of the mouth F, forming an extension, *e*, of the flue E.

The cones C and D are supported in place, preferably, by the fastenings *d'* and *c'*.

F represents the mouth of the stack.

The operation of the invention is as follows: The sparks, first encountering the cone C, and spread outward thereby, are carried upward into and along the flue E, and thence into the extension *e*, and against the deflector B. The force of the steam, as is well understood, is sufficient to cause the sparks to be carried upward with great force. By reason of the shape and arrangement of the flue *e* the sparks, after encountering the deflector, are caused to be thrown in a direction directly opposite to that taken by the steam in its ascent through the mouth F, and to the bottom of the cone D, and thence into the cone C, whence, by the continued action of the escaping steam, they are, through the flue *c*, sucked out into the flue E, and are again thrown upward against the deflector, to be again returned, through the flue *e*, to the cone C, and again sucked out and thrown upward, as before, and so on, round and round, until, by repeated collision with and abrasion upon the deflector D, the fire is beaten out of the sparks, and by this time the sparks will have become pulverized to such an extent as to render them too light to be thrown downward from the flue *e* any longer, and they are carried off directly with the escaping steam.

To prevent the steam, as it escapes from the flue *e*, from causing an eddy within the cone C, I arrange a shield, G, within the cone D, care being taken to leave a sufficient annular space between the shield and cone for the descending sparks to pass down into the cone C. The shield is preferably conical in form, as shown, and is supported by the connections *g g*.

By reason of the shape and arrangement of the cone D and the flue E *e*, I am enabled to dispense with the netting that commonly is used at the mouth of the stack, for, the upper end of the cone D being much larger than the mouth of the stack, and the curvature of the deflector being such as to point the mouth of

the flue *e* directly away from the mouth of the stack, the sparks are effectually prevented from going in the direction of the mouth F until they are thoroughly pulverized.

I claim—

1. The combination of the stack A, deflector B, cone C, and cone D, the latter being extended upward, as described, to form the flue E and extension *e*, substantially as set forth.

2. The combination of the stack A, deflector B, cones C, D, and G, and flues *c* E *e*, substantially as described.

JOHN HEWITT.

Witnesses:

CHAS. D. MOODY,  
HERM. GUELS.