

R. A. KEARNS, W. D. LEWIS & W. M. JENKINS.

Brick-Machine and Mold.

No. 198,119.

Patented Dec. 11, 1877

Fig. 1.

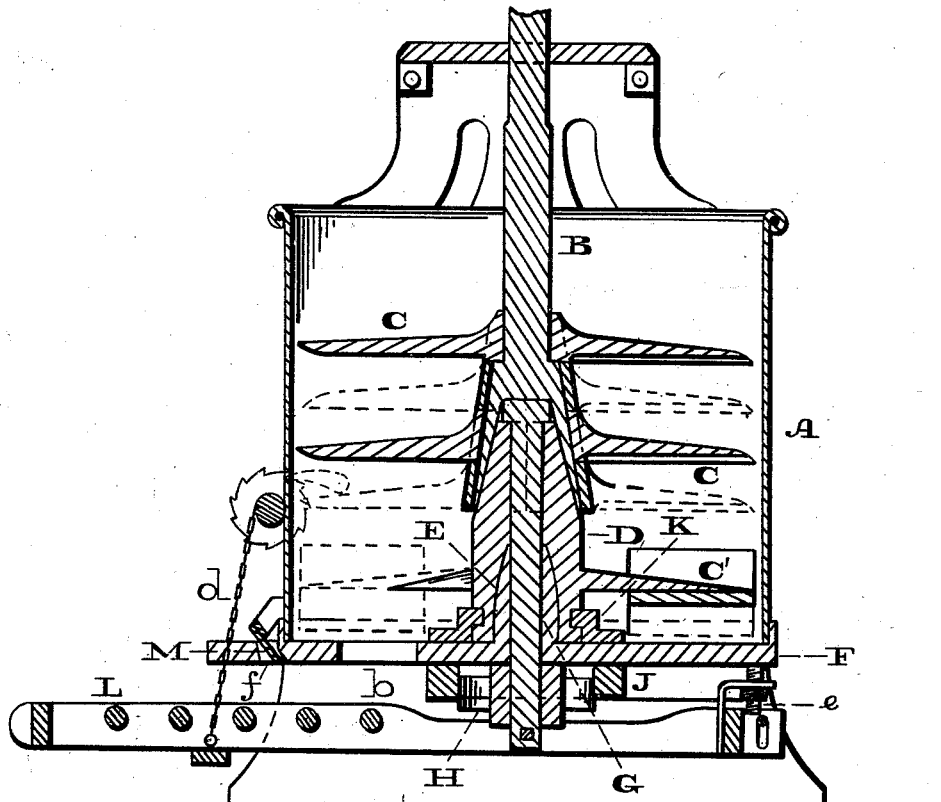
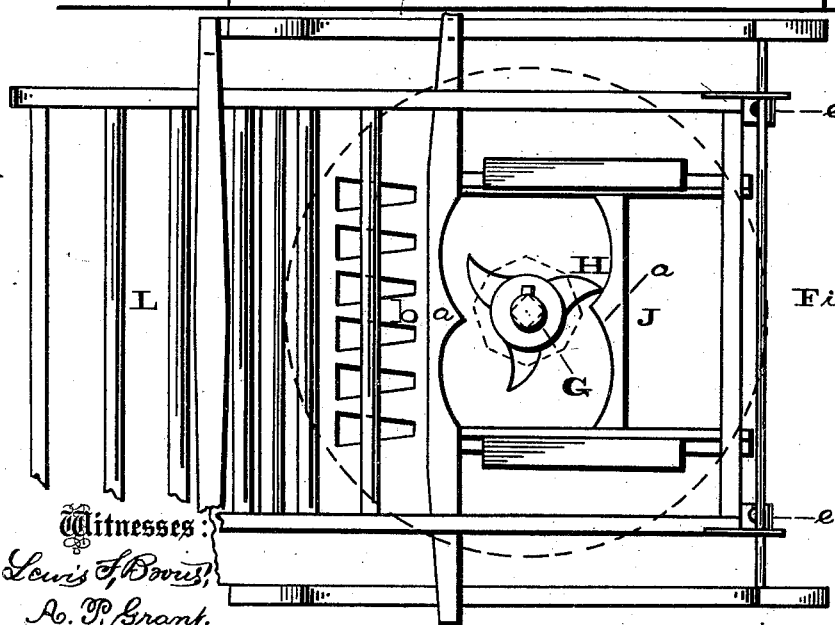

Fig. 2.



Witnesses:  
*Lewis & Davis*  
*Co. P. Grant.*

Inventors:  
*R. A. Kearns,*  
*W. D. Lewis,*  
*Wilson M. Jenkins*  
*John A. Diederheim*  
*Attorney.*

R. A. KEARNS, W. D. LEWIS & W. M. JENKINS.

Brick-Machine and Mold.

No. 198,119.

Patented Dec. 11, 1877.

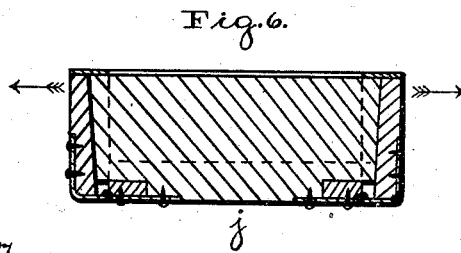
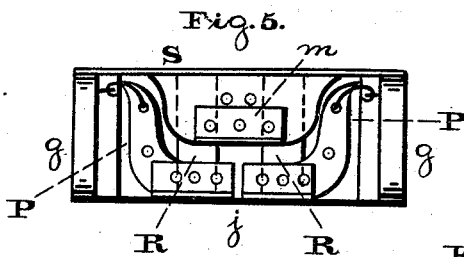
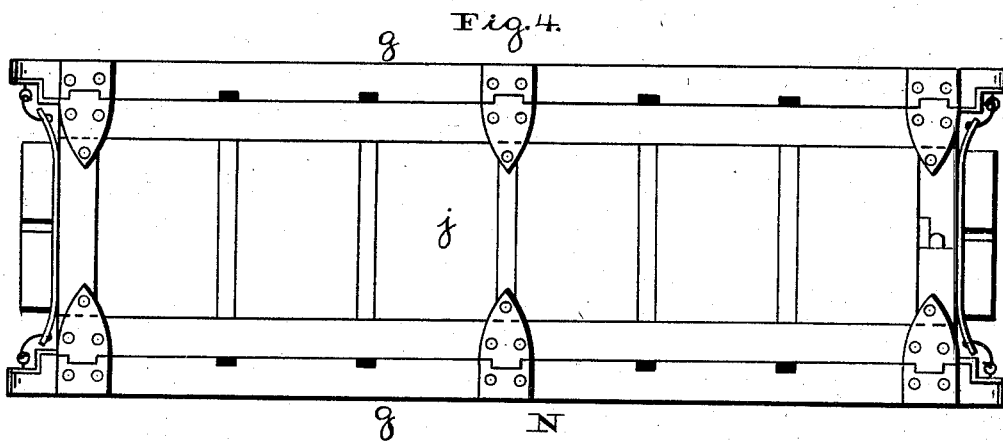
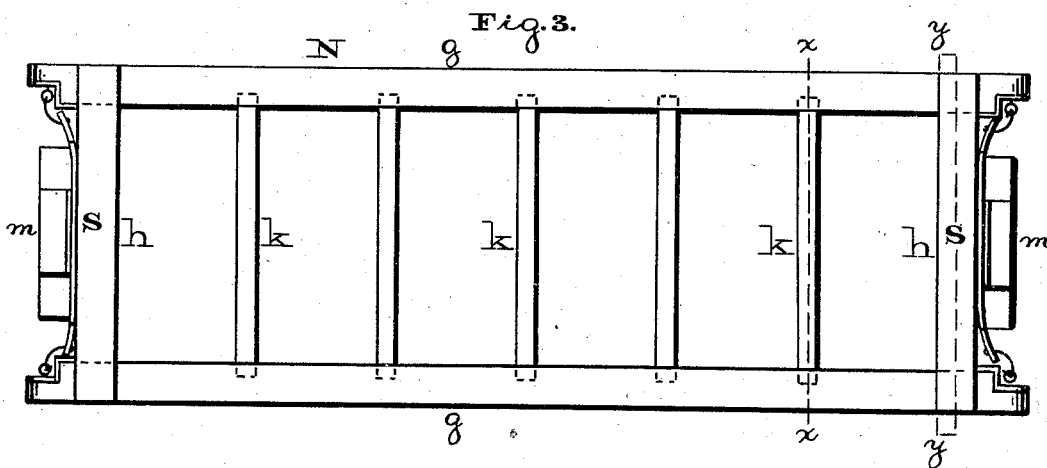

Witnesses:  
*Lewis F. Brown,*  
*No. P. Grant.*

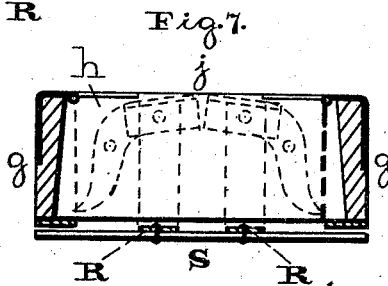

Inventors:  
*R. A. Kearns,*  
*Wm. D. Lewis,*  
*Wilson M. Jenkins*  
*Johann A. Dedering*  
*Attorney.*

# UNITED STATES PATENT OFFICE.

RICHARD A. KEARNS, WILLIAM D. LEWIS, AND WILSON M. JENKINS, OF  
PHILADELPHIA, PENNSYLVANIA.

## IMPROVEMENT IN BRICK MACHINES AND MOLDS.

Specification forming part of Letters Patent No. **198,119**, dated December 11, 1877; application filed  
November 9, 1877.

*To all whom it may concern:*

Be it known that we, RICHARD A. KEARNS, WILLIAM D. LEWIS, and WILSON M. JENKINS, all of the city and county of Philadelphia and State of Pennsylvania, have invented a new and useful Improvement in Brick Machines and Molds, which improvement is fully set forth in the following specification and accompanying drawings, in which—

Figure 1 is a central longitudinal vertical section of the brick-machine embodying our invention. Fig. 2 is a bottom view thereof. Fig. 3 is a top view of the molds. Fig. 4 is a bottom view thereof. Fig. 5 is an end view thereof. Fig. 6 is a transverse section in line *x x*, Fig. 3, and Fig. 7 is a transverse section in line *y y*, Fig. 3, inverted.

Similar letters of reference indicate corresponding parts in the several figures.

Our invention consists of the beater-shaft, bottom hub, and tapped stem, so constructed and connected that mud and water cannot pass between or through the joints of said shaft and hub and the bed-plate, and the said shaft, hub, and stem are not liable to twist, and they may be easily applied and removed.

It also consists in connecting the hub to the bed-plate by a tongued or grooved collar, whereby vertical play of the hub is prevented.

It also consists of a carriage for advancing the filled molds, so combined with a tappet that there are several motions to each rotation of the beater-shaft.

It also consists of a mold-supporting rack made vertically adjustable.

It also consists of a plane projecting through a throat in the bed-plate, so as to throw the surplus mud over the plane outside of the bed-plate.

It further consists of a mold having expansible sides, in order to cause the easy shedding of the molded brick, said sides being hinged to the bottom piece of the mold, and operated by levers hinged to the end pieces thereof, whereby, when the mold is grasped at the end pieces, the levers may be immediately operated.

It also consists of levers for expanding and restoring the expansible sides.

It also consists of the mold having "knock-

offs" or feet, for overcoming the friction or sticking of the molded brick.

Referring to the drawings, A represents the cylinder or hopper, suitably supported, and B the shaft, on which are fitted the beaters or blades C rotating within the cylinder. The lower portion of said shaft B is hollow, and squared internally, and it overhangs and engages with the squared end of a hub, D, which carries wings C', and overhangs and is fitted on a boss, E, rising from the bed-plate F.

Through the hub and boss is passed a stem, G, a portion of which is squared to engage with a corresponding squared portion of the inner face of the hub, and the lower end of the stem projects below the bed-plate F, where it has connected to it a three-winged tappet or cam, H, which is adapted to engage with faces *a* projecting in reverse order on opposite sides of a carriage, J, arranged adjacent to the under face of the bed-plate, and mounted in guides suitably connected to said plate.

It will be seen that, owing to the connection of the shaft B and hub D, and of the latter and the stem G, the shaft, hub, and stem rotate as one, and said parts are strong, not liable to twist, and easily applied and removed.

By this provision, also, the mud and water cannot pass out through the bed-plate, excepting through the proper dies, the joints of the shaft, hub, and boss preventing the entrance between them of the mud and water.

In order to hold the hub D in position, the circumference thereof is grooved, and into the groove projects a tongue formed on the inner face of a collar, K, which is secured to the bed-plate F, whereby the hub is held in position, and vertical play thereof is prevented.

In the bed-plate F there are dies or openings *b*, located at what will be in front of the carriage J, and designed for the exit or passage of the mud or clay to the molds, which will be placed on a rack, L, the front end of which is adjustably suspended by chains or cords *d*, connected to a shaft controlled by a ratchet and pawl, and journaled to a proper portion of the cylinder or the supports thereof, and the rear end is connected to screw-bolts *e*, fitted to the bed-plate or elsewhere, whereby the rack is capable of vertical adjust-

ment, in order to cause the molds to be supported and move true to their work, and admit of the employment of molds of different sizes.

The front of the bed-plate has a throat, *f*, and through the same projects an angularly-arranged plane, *M*, which overhangs the rack *L*, and is adapted for removing the surplus mud or clay at the top of the mold or molds, and imparting a smooth finish to the upper face of the molded substance, the surplus mud passing over the plane and outside of the bed-plate.

The operation is as follows: The mud or clay will be placed in the cylinder, and it emerges therefrom through the dies *b*, there being as many dies as there are molds to be filled at one operation, the action of the beaters or blades and wings on the mud or clay being well known. Owing to the rotation of the shaft *B* and hub *D*, motion is imparted to the tappet *H*, the wings whereof engage alternately with the opposite faces *a* of the carriage *J*, whereby to each rotation of the shaft *B* there are six motions of the carriage, viz., three advancing and three returning, the greatest number of motions of the carriage within a given time thus being produced.

When one wing of the tappet strikes the front face *a* of the carriage *J*, it advances the carriage. When said face is cleared, another wing immediately strikes the rear face *a* and returns the carriage, and as soon as said rear face is cleared the remaining wing immediately engages with the front face. These actions and movements are repeated, and all are accomplished when the shaft has completed one revolution.

The mold is placed on the rack from the side of the machine, so as to come in front of the carriage and under the dies which fill the mold, and the carriage then moves the filled mold forward on the rack, in which movement said mold reaches the presented edge of the plane *M*, the action of which has been stated, and it is presented in front of the rack, where it may be removed by hand, or by a conveyer, for the next operation in brick-making. Meanwhile the carriage is drawn back, and another mold is placed on the rack and filled. The carriage quickly advances and forces forward the filled mold, and again recedes, so that another mold may be placed on the rack, it being noticed that three molds or three sets of molds have been filled and advanced to one rotation of the shaft *B*, whereby the work will be expeditiously performed.

*N* represents a gang of molds, consisting of the side pieces *g*, end pieces *h*, bottom piece *j*, and transverse partitions *k*, thus, in the present case, producing six molds to be filled at one operation. The side pieces *g* are hinged to the bottom piece *j*, and have limited outward motions on their hinges, and the partitions *k* project unattached into grooves on the inner faces of the side pieces.

To the end pieces *h* there are hinged levers

*P*, the outer ends of which are connected to the side pieces *g*. To the levers *P* there are also connected sliding bars *R*, which pass through grooves or openings in the end pieces *h*, and are connected to plates or feet *S*, extending transversely on the outer edges of the end pieces.

When the mold is on the rack and in contact with the under side of the bed-plate, the plates *S* will be forced down. This action also forces down the bars *R*, which, being connected to the levers *P*, draw in the upper or other ends of the latter, thus forcibly bringing the side pieces toward each other, and, apparently, producing a solid mold, there being no exposed crevices for entrance of the mud or clay. After the molds are filled and removed from the rack or conveyer, the gang is carried to the drying-floor and inverted.

The finger and ball of the hand being placed on projections or purchases *m* on the end pieces of the mold, and also on projecting pieces of the levers *P*, the power of the hands is now exerted on the levers *P*, whereby the movement of the levers is communicated to the side pieces *g*, and these pieces open outward, thus expanding the molds laterally, and relieving the ends of the molded bricks of the friction of the side pieces, whereby the molds will readily shed their contents.

It will be noticed that the plates *S* have separated from the outer edges of the end pieces *h* and elevated the inverted mold, and if there is any tendency of the molded brick to stick during the shedding operation, the mold will be smartly struck or knocked, the projecting plates *S* receiving the blows, and the bricks will quickly clear themselves without affecting their exposed faces, and with a preservation of shape and finish on all sides.

The side pieces *g* are again drawn or pushed in, and the series of molds or the gang is closed for the subsequent operations of filling and shedding, as above stated, the knock-off plates or feet *S* returning to their normal positions, in close contact with the outer edges of the end pieces *h*.

Having thus described our invention, what we claim as new, and desire to secure by Letters Patent, is—

1. The shaft *B*, hub *D*, and stem *G*, constructed and combined substantially as and for the purpose set forth.

2. The hub *D* and collar *K*, connected by tongue and groove, and combined with the bed-plate, substantially as and for the purpose set forth.

3. The cylinder *A*, in combination with the carriage *J* and the winged tappet *H*, substantially as and for the purpose set forth.

4. The cylinder, in combination with the rack *L*, made vertically adjustable by means of the front chains or cords *d*, connected to a shaft controlled by a ratchet and pawl, and the rear screw-bolts *e*, substantially as and for the purpose set forth.

5. The bed-plate with the throat *f*, in com-

bination with the plane M, fitted angularly within said throat, and overhanging the rack or support of the mold, whereby the surplus mud or clay passes through the throat, over the plane, and outside and above the bed-plate, substantially as and for the purpose set forth.

6. The mold, having expansible side pieces *g* hinged at their lower ends to the bottom piece *j*, in combination with the operating levers fitted to the end pieces *h*, substantially as and for the purpose set forth.

7. The levers P, in combination with the

expansible side pieces *g* of the mold, substantially as and for the purpose set forth.

8. The movable knock-off plates or feet S, in combination with the ends or sides of the mold, substantially as and for the purpose set forth:

RICHARD A. KEARNS.  
WILLIAM D. LEWIS.  
WILSON M. JENKINS.

Witnesses:

WM. LARZELERE,  
JOHN A. WIEDERSHEIM.