

F. KLINGMUELLER.  
Gas-Meter.

No. 198,122.

Patented Dec. 11, 1877.

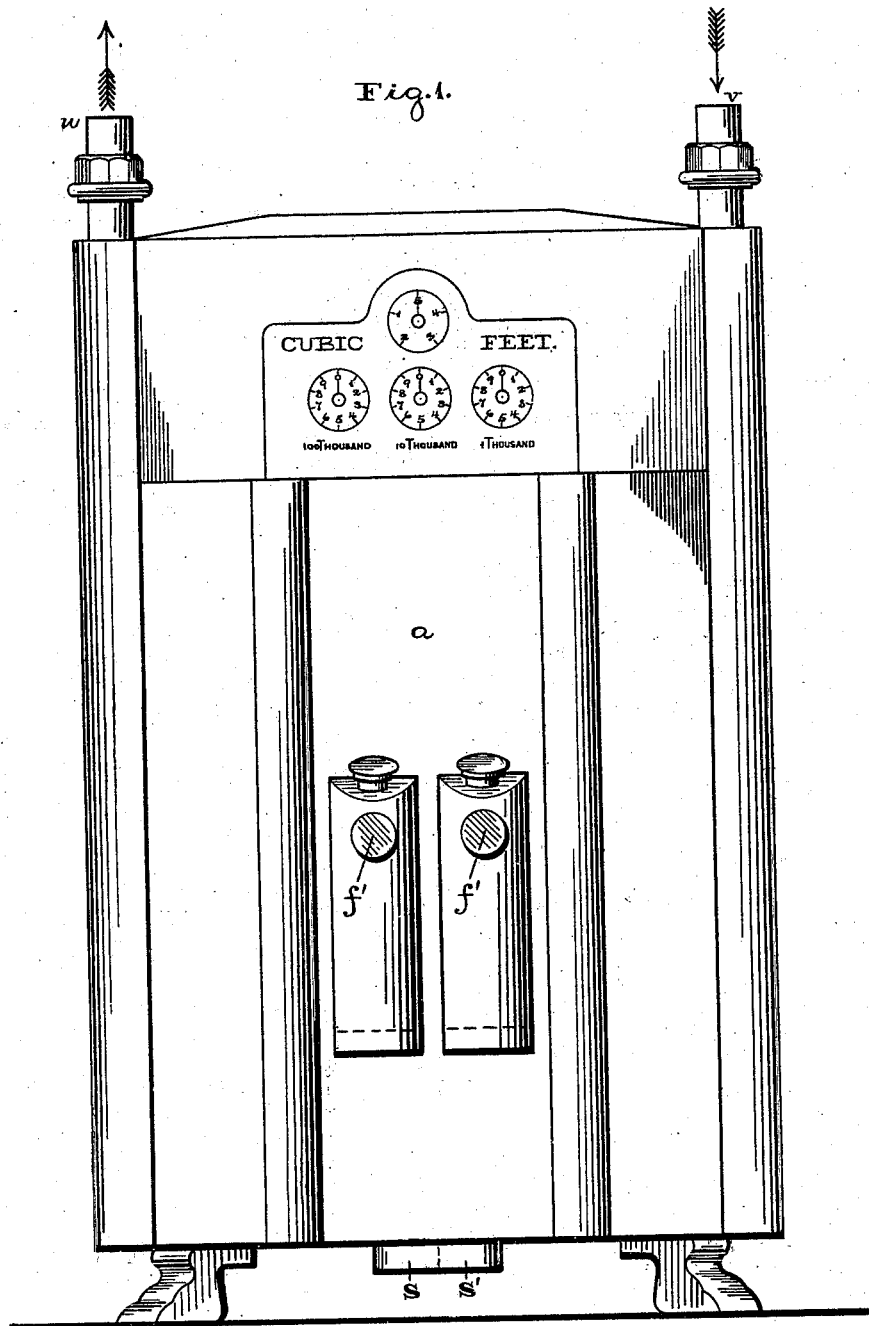

Witnesses:  
*Lewis T. Brown,*  
*Ro. P. Grant.*

Inventor:  
*F. Klingmüller*  
 by  
*John A. Dickerson*  
 Attorney.

F. KLINGMUELLER.  
Gas-Meter.

No. 198,122.

Patented Dec. 11, 1877.

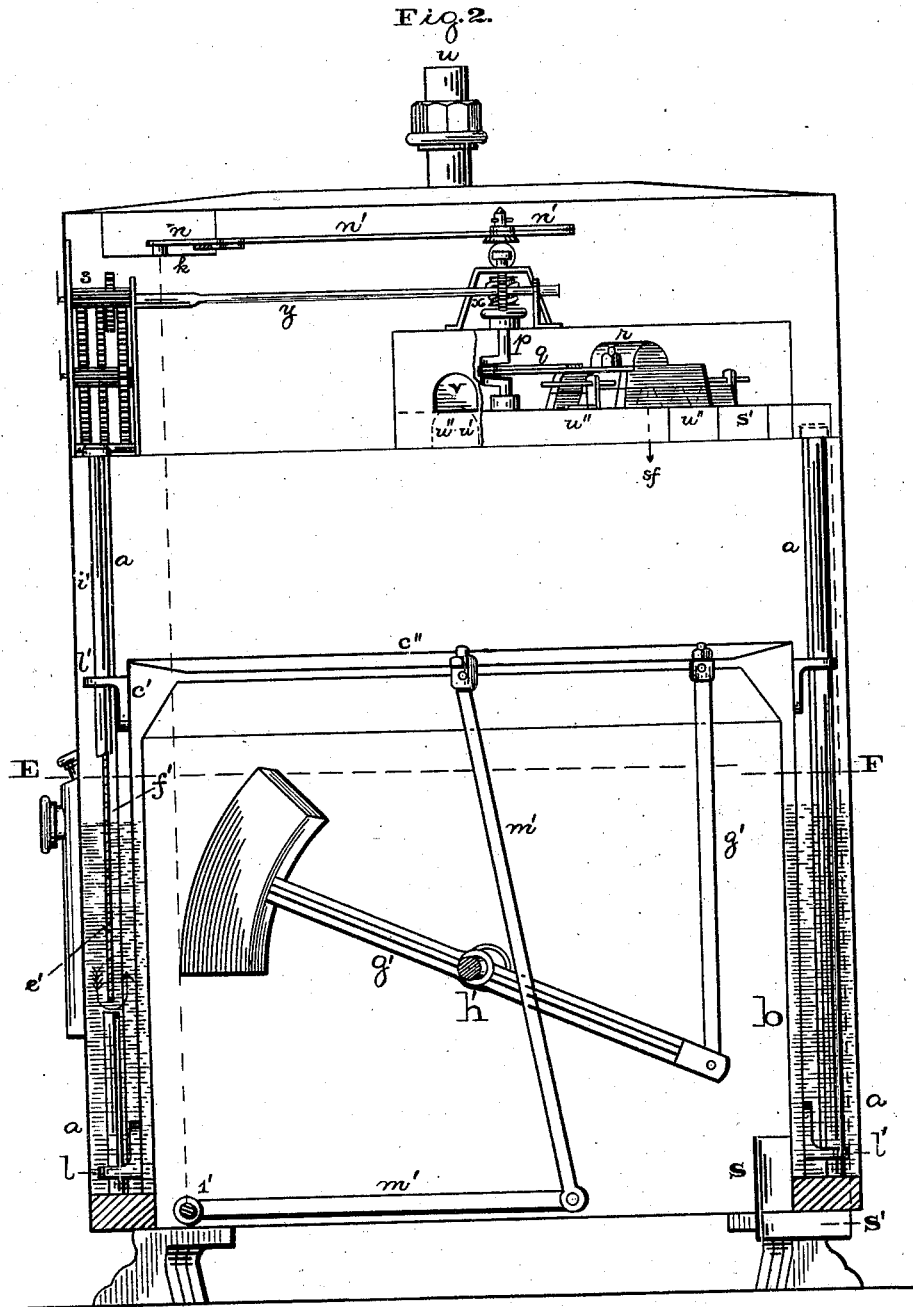

Witnesses:  
*Lewis F. Brown,*  
*Do. P. Grant.*

Inventor:  
*Fr. Klingmüller,*  
by *John A. Gaderbauer*  
Attorney.

F. KLINGMUELLER.  
Gas-Meter.

No. 198,122.

Patented Dec. 11, 1877.

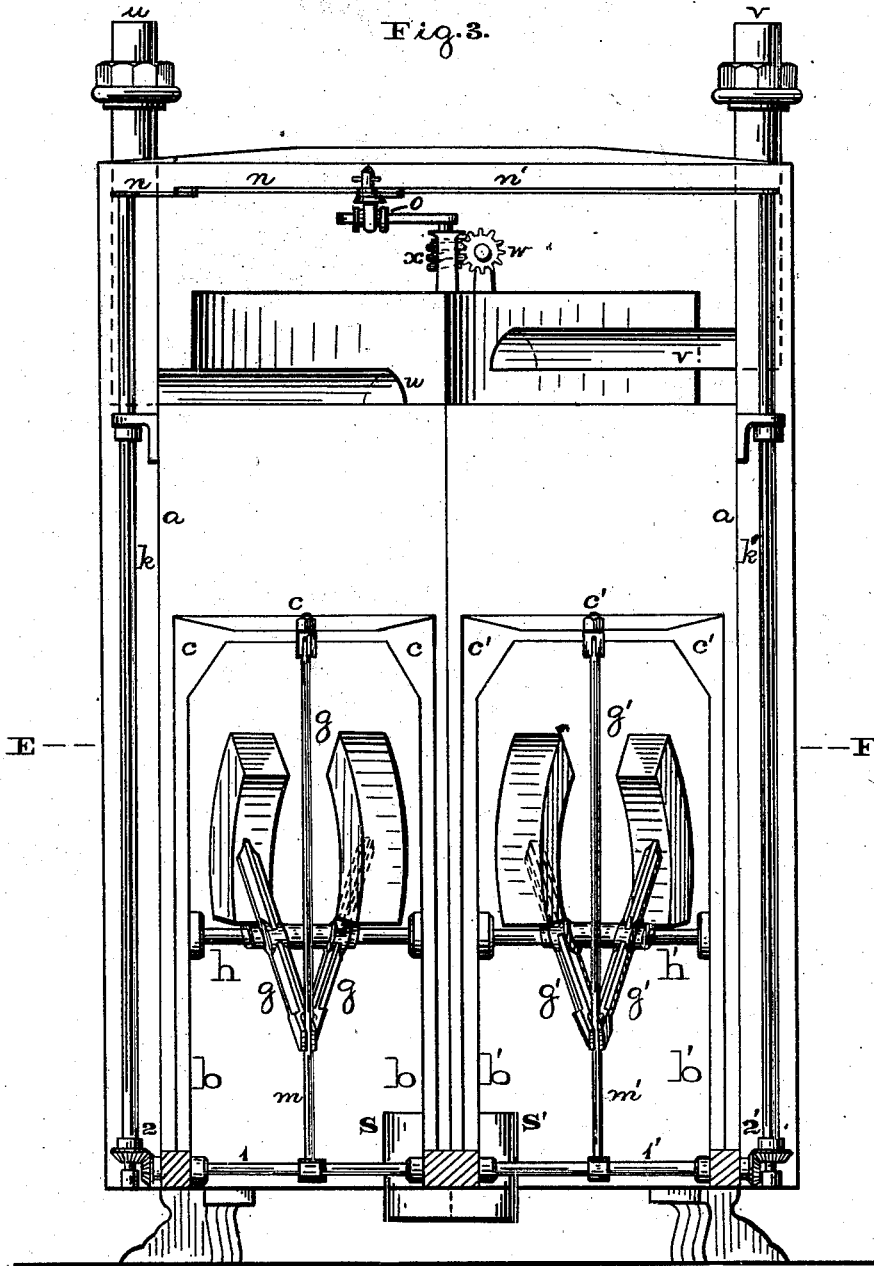

Witnesses:  
*Lewis F. Brown,*  
*No. P. Grant.*

Inventor:  
*F. Klingmüller,*  
 by *Julius Dierschke*  
 Attorney.

F. KLINGMUELLER.  
Gas-Meter.

No. 198,122.

Patented Dec. 11, 1877.

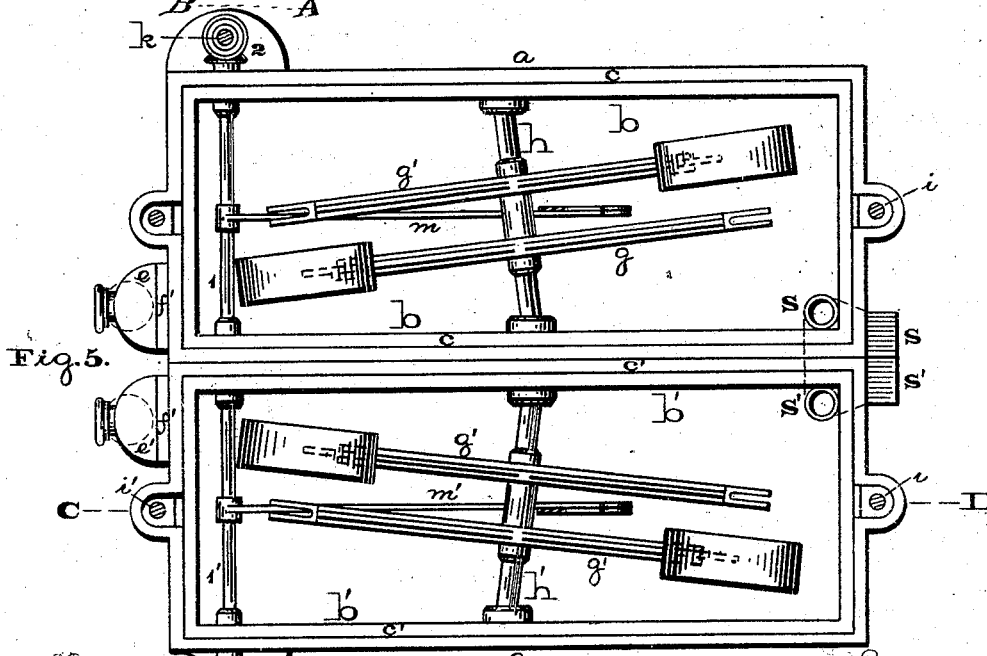
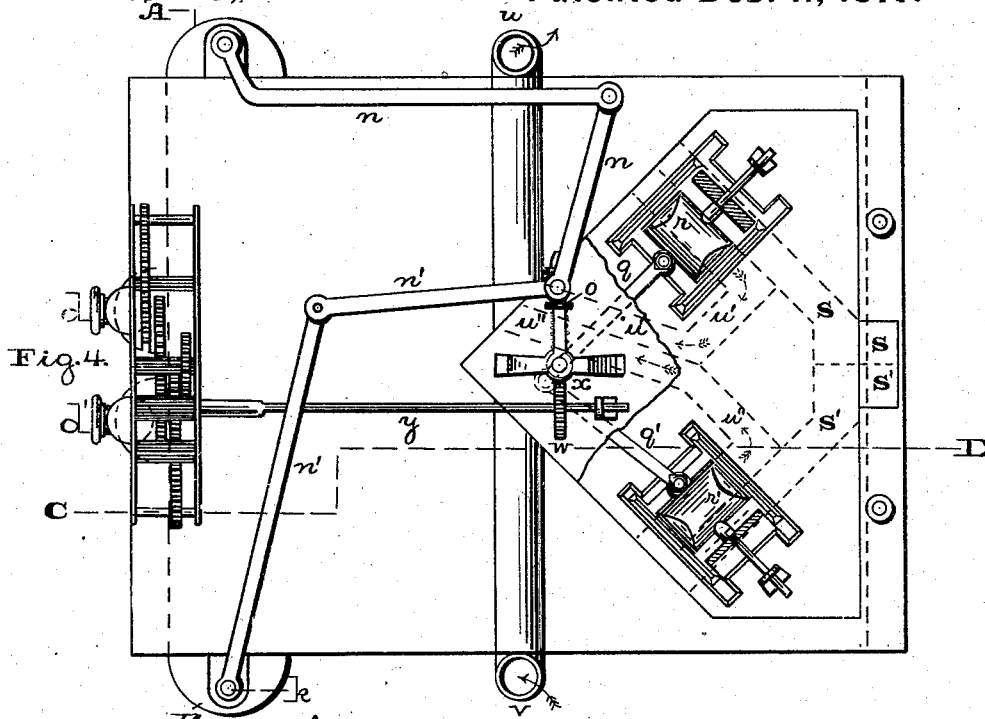

Witnesses:  
*Lewis F. Brown*  
*W. P. Grant*

Inventor:  
*F. Klingmüller*  
 by *John A. Diederichsen*  
 Attorney.

# UNITED STATES PATENT OFFICE.

FRIEDRICH KLINGMUELLER, OF PRAGUE, BOHEMIA, AUSTRIA.

## IMPROVEMENT IN GAS-METERS.

Specification forming part of Letters Patent No. **198,122**, dated December 11, 1877; application filed July 23, 1877.

*To all whom it may concern:*

Be it known that I, FRIEDRICH KLINGMUELLER, of Prague, in Bohemia, Empire of Austria, have invented a new and useful Improvement in Gas-Meters, of which the following is a specification:

The object of this invention is to construct a gas-meter in such a manner as to overcome the main objections of ordinary dry and wet gas-meters.

The ordinary wet gas-meters are objectionable because they are liable to freeze when exposed to cold temperature, and because they offer a large surface of water to the gas, in consequence of which the water is rapidly evaporated, thus necessitating frequent refilling.

When glycerine is used instead of water, the wet gas-meters are very expensive, on account of their requiring so much fluid.

Dry gas-meters, on the other hand, are rapidly deteriorated, especially by impure gas. They are also open to the objection that when out of use the leather parts become dry, so as to prevent their working.

Gas-meters constructed according to the present invention require only a small quantity of glycerine, can be worked at a greater speed, and can be made smaller than ordinary wet gas-meters without being liable to deterioration when out of use.

The accompanying drawings illustrate a suitable form of construction of gas-meter according to this invention.

Figure 1 is a side view. Fig. 2 is a vertical section in line C D, Fig. 4. Fig. 3 is a vertical section in line A B, Figs. 4 and 5. Fig. 4 is a top view. Fig. 5 is a horizontal section in line E F, Fig. 2.

Similar letters of reference indicate corresponding parts in the several figures.

Referring to the drawings, *a* represents a metal case divided by a horizontal partition into upper and lower chambers. This outer case incloses an inner case, divided vertically into two chambers, *b b'*.

Within the inner case *b* there is located a bell or float, *c*, and within the case *b'* there is located a bell or float, *c'*. For each of the chambers *b b'* separate filling-boxes *d d'* are

arranged in the outer case, and these boxes are provided with partition-pieces *e e'*, fixed inside to their tops and reaching nearly down to the bottoms, and so as to leave apertures *f f'*, through which the filling or sealing liquid poured into these boxes can pass into the spaces between the case *a* and the two inner chambers *b b'*. The overflow-screws of the filling-boxes are arranged higher than the lower edge of the partitions *e e'*, so that said partitions are always submerged in the fluid.

In each of the chambers *b b'* there are two weighted levers, *g g'*, which are fastened at one of their ends to the top of the bells *c c'*, and are mounted on shafts *h h'*, their object being to counterbalance the bells. The bells are provided with ways *l l'*, through which pass rods *i i'* for guiding the vertical movement of the bells. To the tops of the bells there are secured the upper ends of jointed rods *m m'*, whose lower ends are connected to horizontal shafts *1 1'*, each of which is provided at one end with a bevel-pinion gearing with another bevel-pinion, *2 2'*, fixed to shafts *k k'*, whose upper ends are connected by knee-joints *n n n' n'* to the crank-pin *o* of a crank-shaft, *p*, located in the upper chamber of the case *a*. The crank-shaft *p* carries a worm, *x*, which gears with a worm-wheel, *w*, on the shaft *y*, carrying the first counter-wheel of the counter 3. The crank-shaft *p* passes through a stuffing-box into a valve-chest in the upper chamber of the case, and has connected to it the rods *q q'* of distributing slide-valves *r r'*.

The gas enters the valve-chest through the pipe *v*. The escape takes place through the escape-pipe *u' u''* beneath the valve-chest. To prevent gas escaping out of the bells into the spaces above them, the intermediate spaces *b b'* are filled with glycerine, of a strength, say of 18° Baumé. The distributing-valves *rr'* are arranged at an angle of ninety degrees, so that their rods *q q'* are at right angles. Below each distributing-valve are three openings—one, *s s'*, communicating with the space below its corresponding bell; one, *s f*, communicating with the space above its corresponding bell; and one, *u' u''*, for the escape of the gas.

When the gas-meter has been supplied with glycerine, as above explained, the gas is al-

lowed to pass into the valve-chest through the pipe *v*. From here the gas passes, first, through the opening *s* of the first valve *r* to below its corresponding bell *c*, and raises the same. As soon as the first bell, *c*, has risen by one-fourth of its upward stroke, the second valve, *r*, is opened, and allows the gas to pass through the opening *s'* to below its corresponding bell *c'*, which is likewise raised. As soon as this second bell, *c'*, has reached three-fourths of its upward stroke, the first bell, *c*, will have completed its upward stroke, and will then begin to descend, while the second bell, *c'*, continues to rise, because by the altered position of the first valve, *r*, the opening *s* communicating with the space beneath the first bell, *c*, has been closed, while the opening *s f*, communicating with the space above the same, has been uncovered, thus allowing the gas to enter above and press down the bell *c*. In consequence of the falling of the bell *c*, the gas contained therein will be forced out through the pipe *s*, which, by the altered position of the valve, has been brought into communication with the outlet-passage *w'* of the valve *r*, and finally escape through the pipe *u*. When the first bell *c* has completed one-fourth of its downward stroke, the second bell, *c'*, will have risen to its highest point, and it will begin to sink likewise, in consequence of the altered position of its valve, and the passage of gas into the outlet-pipe *w'*. The bells make only three-fourths of their rising or sinking strokes simultaneously. During the fourth quarter of the rising stroke of the one, the second will be in the act of sinking, or vice versa. By this arrangement the dead-points are overcome, and a regular consumption of gas is attained.

By the rising and falling motion of the bells the two horizontal shafts 1 1 are rotated, and

communicate their rotation by means of the bevel-pinions 2 2' to the vertical shafts *k k'*, which rotate the crank-shaft *p* by the knee-joints *n n n' n'*. The crank-shaft *p* alters the position of the valves, and simultaneously, by the worm *x*, communicates its rotation to the wheel *w* on the shaft *y*, which sets the connecting-gearing 3 in motion, thus causing the registration of the gas. The crank-pin *o* is connected to a nut fitted to a threaded arm at the upper end of the crank-shaft *p*, whereby the pin *o* will be connected to said shaft *p*, and provision made for nicely adjusting the several connected parts.

Having thus described my invention, I claim as new and desire to secure by Letters Patent—

1. The bells *c c'* and chambers *b b'*, in combination with the filling-boxes *d d'*, with partial partitions *e e'* and passages *f f'*, substantially as and for the purpose set forth.

2. The bells *c c'*, in combination with the valve crank-shaft *p* and intermediate mechanism, consisting of the jointed rods *m m'*, shafts 1 1', shafts *k k'*, and knee-joints *n n'*, and with the adjustably-connected crank-pin *o*, substantially as and for the purpose set forth.

3. The bells *c c'*, weighted levers *g g'*, jointed rods *m m'*, ways *l l'*, and rods *i i'*, in combination with the shafts 1 1', shafts *k k'*, knee-joints *n n'*, crank-shaft *p*, counter-shaft *y*, valves *r r'*, escape-pipes *w w'*, and pipes *u v*, substantially as and for the purpose set forth.

In testimony whereof I have signed my name to this specification in the presence of two subscribing witnesses.

FRIEDR. KLINGMUELLER.

Witnesses:

J. METZ,  
ADOLF JAKESCH.