

W. V. PERRY.
Car-Coupling.

No. 198,147.

Patented Dec. 11, 1877.

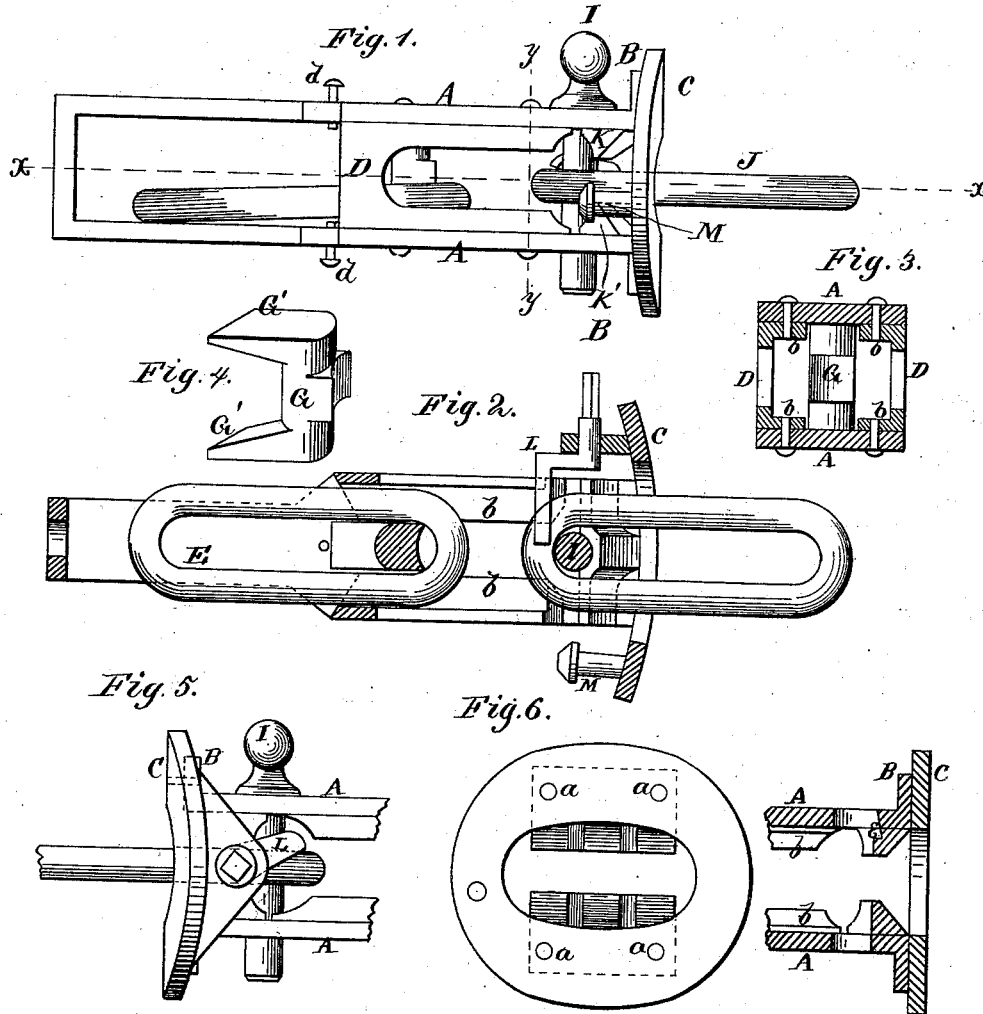

WITNESSES
Henry N. Miller
Frank Galt

INVENTOR
W. V. Perry,
Alexander Mason
ATTORNEYS.

W. V. PERRY.
Car-Coupling.

No. 198,147.

Patented Dec. 11, 1877.

Fig. 7.

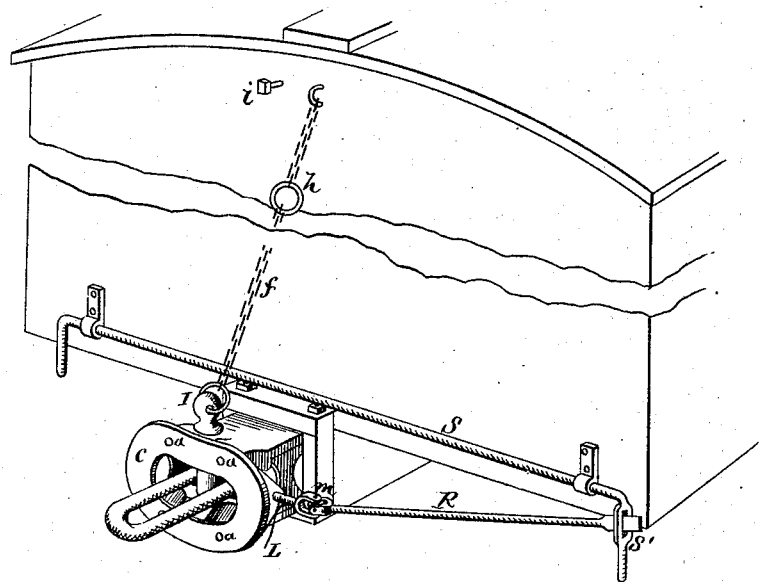

WITNESSES

Henry N. Miller
Frank Gall

INVENTOR

W. V. Perry,
Attorneys
ATTORNEYS

UNITED STATES PATENT OFFICE.

WILLIAM V. PERRY, OF BEAVER DAM, WISCONSIN.

IMPROVEMENT IN CAR-COUPINGS.

Specification forming part of Letters Patent No. **198,147**, dated December 11, 1877; application filed August 16, 1877.

To all whom it may concern:

Be it known that I, WILLIAM V. PERRY, of Beaver Dam, in the county of Dodge, and in the State of Wisconsin, have invented certain new and useful Improvements in Car-Couplings; and do hereby declare that the following is a full, clear, and exact description thereof, reference being had to the accompanying drawings, and to the letters of reference marked thereon, making a part of this specification.

The nature of my invention consists in the construction and arrangement of a car-coupling, as will be hereinafter more fully set forth.

In order to enable others skilled in the art to which my invention appertains to make and use the same, I will now proceed to describe its construction and operation, referring to the annexed drawings, in which—

Figure 1 is a side view of my car-coupling. Fig. 2 is a horizontal section of the same. Fig. 3 is a transverse vertical section through the line *y y*, Fig. 1. Fig. 4 is a perspective view of a movable column or pin. Fig. 5 shows the opposite side of the draw-head, and Fig. 6 is a front view of the same. Fig. 7 shows my car-coupling as applied to the car.

A A represent the main or top and bottom irons of the draw-bar. These irons are connected at their rear ends, and have their front ends turned at right angles, forming flanges B B, to which the draw-head or buffer C is fastened by rivets at *a a*. D D are side pieces fastened to and connecting the main irons A A. These side pieces are extended inward, and form guides *b b*, between which a movable column or pin, G, moves backward and forward, said column or pin being provided with rearwardly-extending flanges or wings G' G', fitting between the guides *b b*.

The column G of itself is made of a size equal to that of the coupling-pin, and can be moved forward to take the place of the ordinary pin, and in the exact place said pin would occupy. If made larger the ordinary link would be too short to couple. The rearwardly-projecting flange or wings G' G' not only act as guides for the column G in moving back and forth in the ways of the draw-head,

but also prevent the column from dropping down through the usual pin-hole.

Around this pin is placed an ordinary car-link, E, which I term a "safety-link." This link is entirely disconnected from the column or pin G, and the sides of the draw-head being open, the link has a free and independent movement around the column, to accommodate the movement of the cars in passing around curves.

d d are check-pins or stops, against which the movable column G abuts, so that it, together with the safety-link E, cannot be lost or stolen.

At the front of the draw-bar are used the ordinary coupling-pin I and link J, the latter passing between lugs K K', formed on or attached to the inner sides of the main irons A A, as shown. The upper lug K forms a step, *e*, upon which the pin I is temporarily held while in the act of coupling.

It is well known that in passenger and live-stock freight trains the slack between the draw-heads of two adjacent cars must be taken up, and this is generally done by inserting blocks between the draw-heads.

In my coupling this is obviated by using the column G behind the pin I in one draw-head, and coupling with the pin in the opposite draw-head, so as to have both the column and the ordinary coupling-pin within the link in one draw-head, and thus shortening the link that much.

In a lug on the back, at one side of the buffer C, is pivoted a crank, L, by means of which the link is lifted for coupling by pressing the inner end of the link down, the lug K' acting as a fulcrum, on which the link turns. On the other side of the buffer is a rearwardly-projecting pin, M, which serves as a fulcrum, over which a rod is to be worked, so as to lift the link without exposing the hand between the buffers in coupling.

The coupling-pin I is, by a chain, *f*, connected with the top of the car, as shown in Fig. 7. In this chain is a large link, *h*, or hand-ring, which is to be lifted and dropped over a bolt, *i*, by the brakeman while on top of the car, thereby allowing the pin to remain ready for coupling when desired.

The crank-lifter L is, by a universal joint, *m*, connected with a rod, R, which has its outer end flattened, and passed through an oblong slot in a handle, S', on a rod, S. This rod can be operated from either side, as shown.

I am aware that a sliding post or bar arranged within the draw-head, and having a link connected thereto, is not new; but I am not aware that heretofore a sliding bar or column has ever been used within a draw-head with a safety-link surrounding it and disconnected therefrom.

By my construction it is only necessary to move the column sufficiently to avoid the incoming link, and the safety-link passes out of the way to the rear of the column—a result not accomplished in those cases where the link is confined to the column.

Having thus fully described my invention, what I claim as new, and desire to secure by Letters Patent, is—

1. The movable column G, having rear-

wardly-projecting flanges at top and bottom, in combination with the safety-link E, disconnected therefrom and surrounding the same, and the draw-head, with channels at top and bottom, for the purposes set forth.

2. The fulcrum M, projecting from the back of the buffer, for the purposes herein set forth.

3. The combination of the top and bottom pieces A A of the draw-bar, the side pieces D D, provided with top and bottom interior projecting flanges *b b*, and connected by bolts to the parts A A, the movable pin G, provided with rearwardly-extending flanges G' G', and the safety-link E, all constructed substantially as and for the purposes herein set forth.

In testimony that I claim the foregoing I have hereunto set my hand this 7th day of August, 1877.

WILLIAM V. PERRY.

Witnesses:

O. L. MOORE,

FRED. J. GALLING.