

F. PETERS.
Dentist's Chair.

No. 198,148.

Patented Dec. 11, 1877.

Fig. 1.

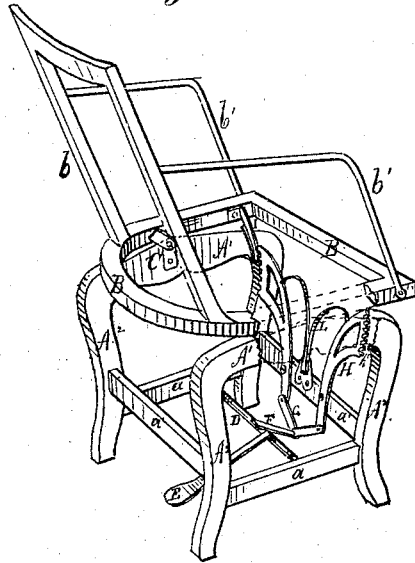

Fig. 2.

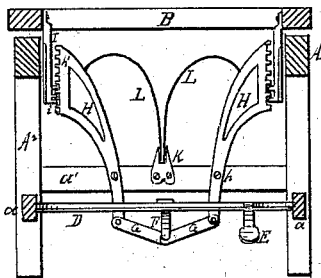
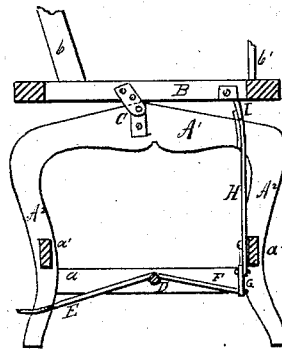

Fig. 3.



Witnesses
S. A. Sully
R. T. Dyer

By

Franz Peters Inventor
Geo. W. Dyer & Co.

Attorneys

UNITED STATES PATENT OFFICE.

FRANZ PETERS, OF CHICAGO, ILLINOIS, ASSIGNOR TO THEODORE A. KOCHS,
OF SAME PLACE.

IMPROVEMENT IN DENTISTS' CHAIRS.

Specification forming part of Letters Patent No. **198,148**, dated December 11, 1877; application filed
June 26, 1877.

To all whom it may concern:

Be it known that I, FRANZ PETERS, of Chicago, in the county of Cook and State of Illinois, have invented certain new and useful Improvements in Barber and Dentist Chairs, of which the following is a full and exact description, reference being had to the accompanying drawing, in which—

Figure 1 is a perspective view of the chair, with a portion of its frame broken away, so as to show the locking mechanism. Fig. 2 is a sectional rear elevation, and Fig. 3 is a transverse section; of the same.

The nature of my invention relates to that class of barbers' and dentists' chairs in which the upper or seat portion is hinged upon the lower or foot portion, so as to admit of a variable inclination of the seat; and it consists of the peculiar mechanism attached to said chair for locking the seat portion rigidly to the lower portion at any desired angle.

A is the lower or foot portion of the chair, framed in the usual manner, with the curved crown-bars A^1 , the feet A^2 , the side braces a , and the front and rear braces a' . B is the upper or seat portion, having the back b and the arm-rests b' . Said seat portion B is secured upon the center of the lower portion A by two side hinges, C, which will permit of a rocking motion to said seat.

A shaft, D, is transversely located between the two braces a of the chair portion A, the ends of which rest in suitable boxes, which are secured to said braces a . To this shaft D are rigidly secured the pedal-bar E and the arm F, in opposite directions to each other.

In the front end of said arm F is formed the pivot for the ends of two links, G, the opposite ends of which are coupled to the extreme bottom ends of two wing-shaped vertical levers, H, fulcrumed at h to the front brace a' of the chair. The upper ends of the levers H form

outwardly-facing toothed rack-bars h' , which match with the teeth i , projecting from the bottom ends of two pendent curved brackets, I, secured to the front sides of the seat-frame B.

K is a bracket, rigidly fixed to the center of the brace-bar a' , holding the lower ends of two upwardly and outwardly curved leaf-springs, L, the upper ends of which press against the upper ends of the levers H, forcing the same apart.

The two links G are placed angularly to each other, so as to form a toggle-joint, which, in depressing the pedal E, will straighten out, thereby forcing the bottom ends of the levers H apart, and causing the teeth h' to disengage from the teeth i of the brackets I, when the seat may be swung forward or back and locked again at any desirable angle by releasing the pedal E, when the springs L will press the upper ends of the levers H apart, thereby causing the teeth h' to couple with the teeth i of the brackets I.

The advantage of the above arrangement is, that the seat, by being locked from both sides, will have a better and more uniform support, and therefore will not get so easily out of order as with the central or one-sided locking device heretofore in use, besides which it adds to the ornamental appearance of the chair.

What I claim as my invention, and desire to secure by Letters Patent, is—

In combination with a chair, A B, the shaft D, having pedal E and arm F, the links G, toothed levers H, springs L, and pendent toothed brackets I, all arranged substantially in the manner described, and for the purpose specified.

FRANZ PETERS.

Witnesses:

WM. H. LOTZ,
EMIL H. FROMMANN.