

W. RIDING.
Loom.

No. 198,156.

Patented Dec. 11, 1877.

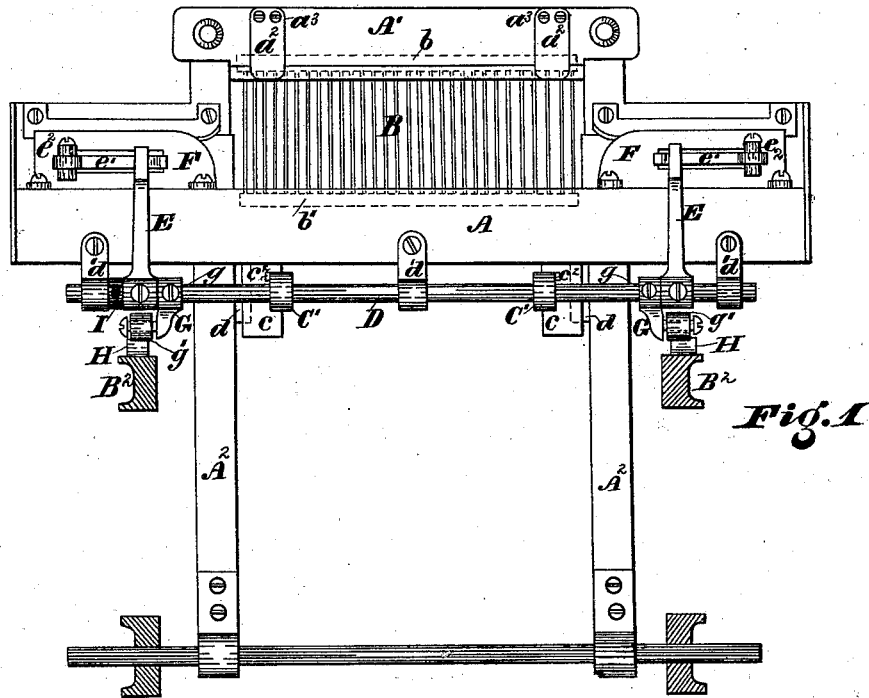

Fig. 1

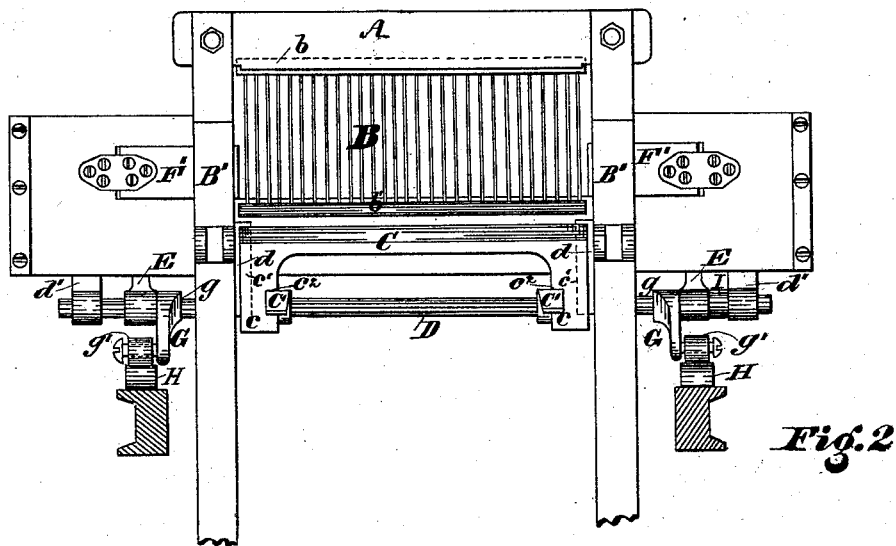

Fig. 2

Witnesses
 Saml. J. Van Stavoren
 Jos. B. Connolly

Inventor
 William Riding,
 Connolly Bros., Attorneys

W. RIDING.

Loom.

No. 198,156.

Patented Dec. 11, 1877.

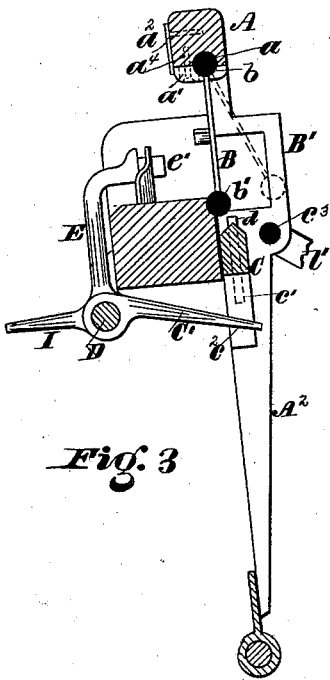

Fig. 3

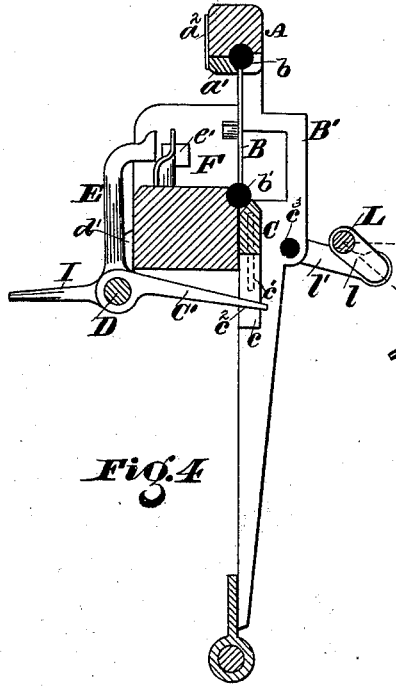

Fig. 4

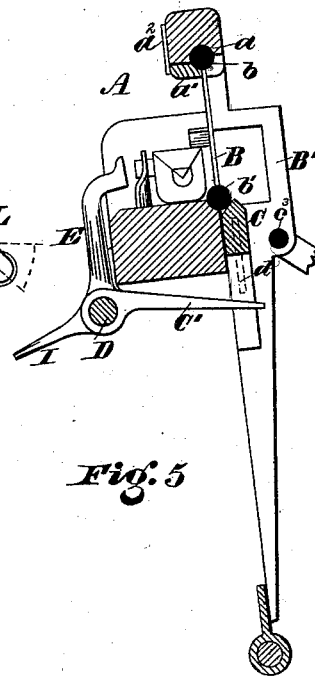

Fig. 5

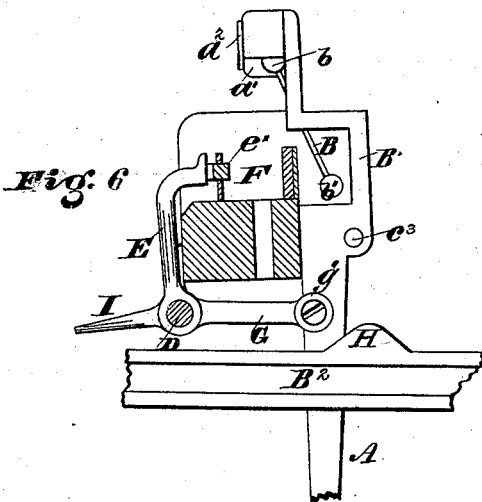

Fig. 6

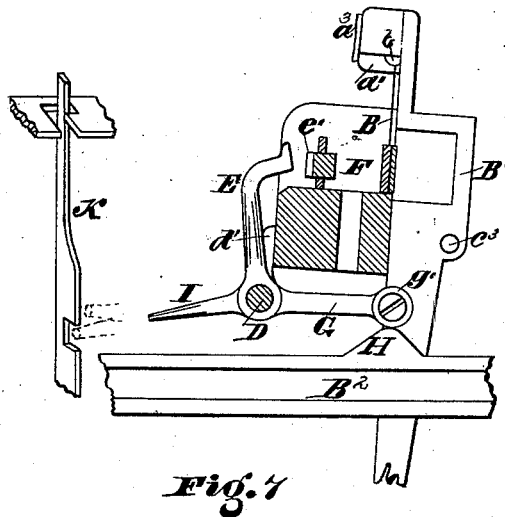

Fig. 7

Witnesses
 Saml. J. VanStavoren
 Jos. B. Connolly

Inventor
 William Riding,
 Connolly Bros, Attorneys

W. RIDING.

Loom.

No. 198,156.

Patented Dec. 11, 1877.

Fig. 8

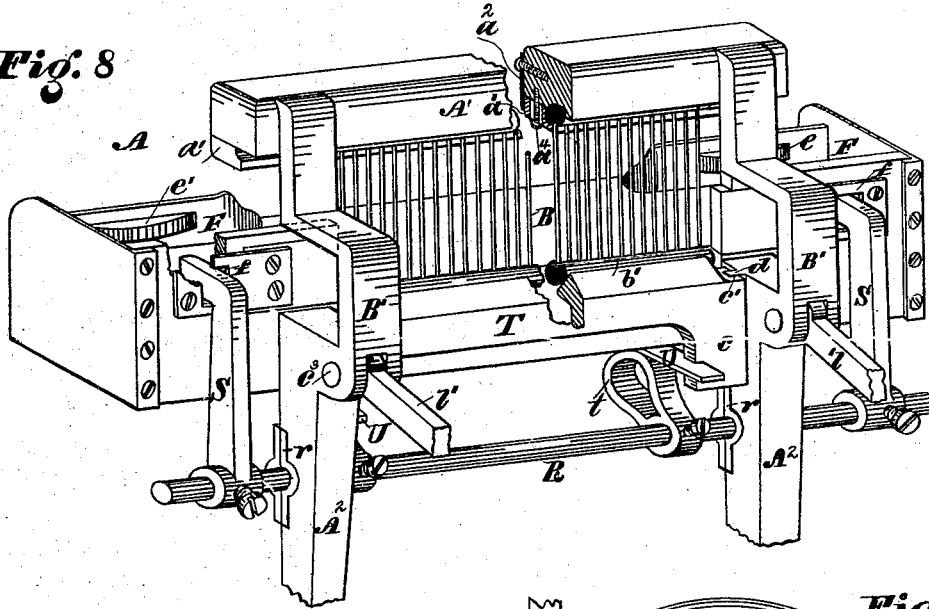

Fig. 10

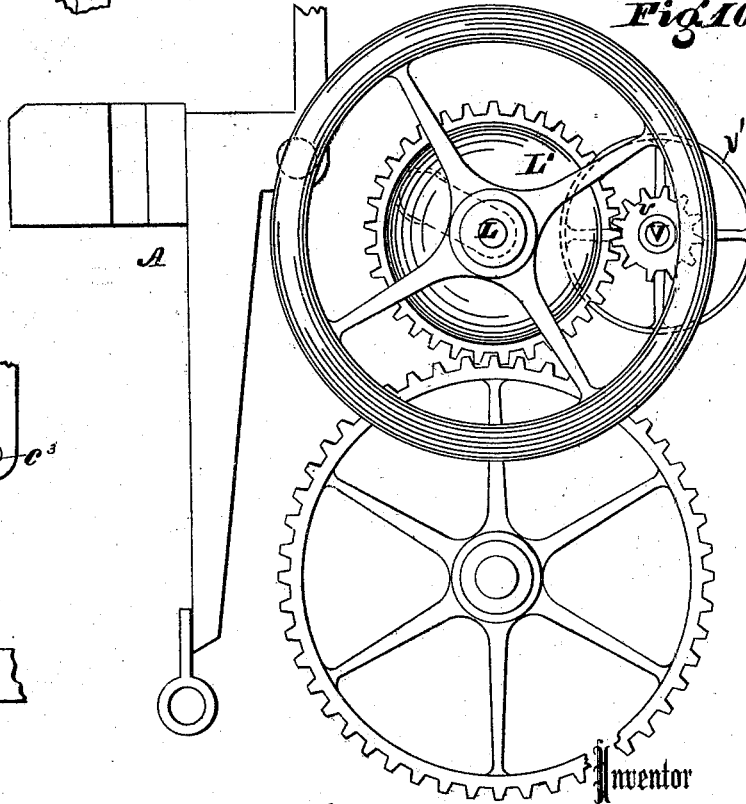
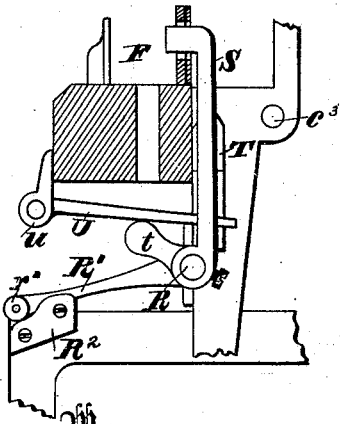

Fig. 9



Witnesses
 Saml J. Vanstavern
 Jos. P. Connolly

Inventor
 William Riding,
 Connolly Bros, Attorneys

W. RIDING.
Loom.

No. 198,156.

Patented Dec. 11, 1877.

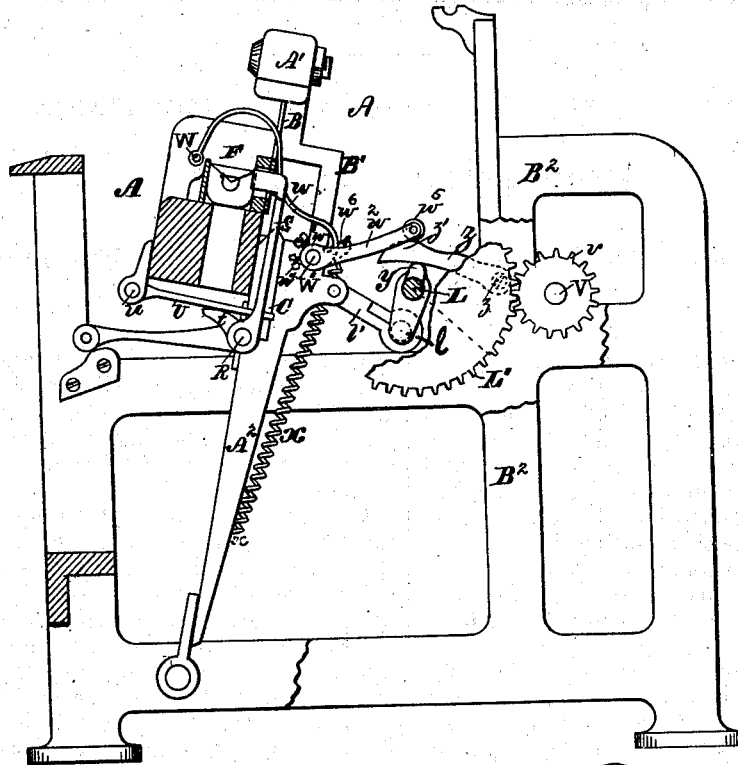

Fig. 11

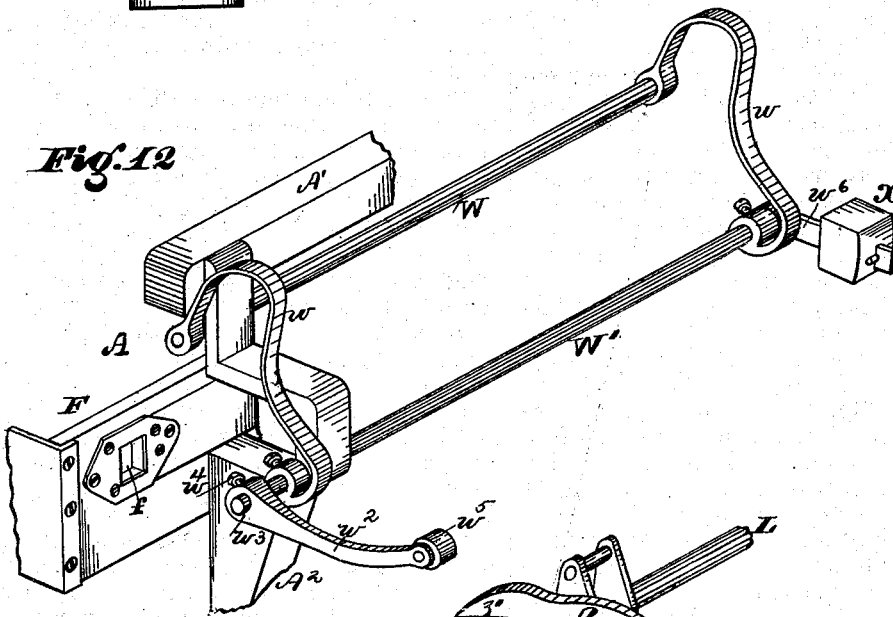

Fig. 12

WITNESSES:
Saml. J. Van Stavoren
Jos. B. Connolly

INVENTOR

William Riding

By Connolly Bros. ATTORNEYS.

UNITED STATES PATENT OFFICE.

WILLIAM RIDING, OF NORRISTOWN, PENNSYLVANIA.

IMPROVEMENT IN LOOMS.

Specification forming part of Letters Patent No. **198,156**, dated December 11, 1877; application filed September 8, 1877.

To all whom it may concern:

Be it known that I, WILLIAM RIDING, of Norristown, in the county of Montgomery and State of Pennsylvania, have invented certain new and useful Improvements in Looms; and I do hereby declare the following to be a full, clear, and exact description of the invention, such as will enable others skilled in the art to which it pertains to make and use it, reference being had to the accompanying drawings, which form part of this specification, in which—

Figure 1 is a front elevation of a lay of a loom with my improvements attached thereto. Fig. 2 is a rear view of the same. Fig. 3 is a transverse vertical section of the lay in its forward position, showing the reed unlocked and free to swing. Fig. 4 is a transverse vertical section of the lay midway on its return motion, showing the reed locked. Fig. 5 is a transverse vertical section of the lay on its forward motion, showing the shuttle in one of the boxes and the reed locked. Fig. 6 is a broken transverse vertical section of the lay, showing the position of the cam H and arm G when the reed is unlocked. Fig. 7 is a similar section of the same parts, showing the reed locked. Fig. 8 is a perspective, partly broken away, of the upper part of the lay of a loom, with a modification of my improvements applied thereto as adapted to looms without swell-fingers. Fig. 9 is a broken transverse vertical section of the same. Fig. 10 is a broken side elevation of a loom with my improved running-gear applied thereto. Fig. 11 is a transverse vertical section of a loom with my improvements for preventing the shuttle from flying out front. Fig. 12 is a perspective of the latter improvements.

The first part of my improvements has for its object the prevention of "smashes" in weaving.

My improvements have for their further object to provide for the ready removal of the reed without taking off the lay-cap, to cause the lay to "dwell" when the shuttle is coming home, and to effect the rapid starting and stoppage of the loom at proper times.

My invention consists in the novel construction and combination of parts, as hereinafter fully set forth.

Referring to the accompanying drawings,

A represents the lay of a loom, and A¹ its cap, the latter having a cylindrical or rounded groove, *a*, on its under side.

B is the reed, having its upper and lower edges turned over rods, forming beads *b* and *b'*, respectively.

C is a bar back of the reed, having depending arms *c c*, recessed at *c'* for the reception of the tongues or ribs *d* on brackets B'B', formed on or attached to the swords A², or the back-board may slide in suitable ways formed on the brackets. The bar C is thus allowed to move up and down as upon ways or in guides, so as to lock and release the reed B, as herein-after set forth. Said reed B is held in the groove *a* by a slide, *a'*, attached to the lay-cap A¹ by screws *a'* passing through slotted openings in said slide, and by springs *a*² fastened to the lay-cap at *a*³.

By simply moving this slide upon the retaining-screws, the reed may be easily inserted in or removed from its groove *a*. The slide also prevents the bar *b* from binding, the slide and springs being adapted to yield against any tendency to bind.

*c*² are slots or grooves formed in the arms or pendants *c*, for the reception of the ends of the arms C'C', which are secured to the rock-shaft or protection-rod D, which has its bearings in hangers *d' d'*, secured to the front of the lay, as shown.

E E are other arms, secured to the shaft or rod D, having their upper extremities curved or bent so as to impinge against the swell-fingers *e'*, which are hinged at *e*² to the shuttle-boxes F.

G is still another arm, secured to the shaft or rod D at *g*, projecting rearwardly under the lay, as shown, in line with the side frames of the loom, so that the anti-friction roller *g'*, with which it may be provided will ride upon the cam or ridge formed on or attached to said frame, said cam being shown at H.

I is another arm, attached to the shaft or rod D, designed to strike the stop-rod K when the shuttle is not home in one of the boxes at the right time.

The bar C is of sufficient length to lap upon and serve to hold fast the hinged backs F' F' of the shuttle-boxes when said bar is elevated, as hereinafter set forth.

L represents the crank-shaft, and *l l* the

cranks thereof, from which extend two pitmen, *U' U'*, pivoted to the brackets *B' B'*. The cranks and pitmen are so adjusted with reference to the lay that the latter will dwell when the former are moving from their lower to their upper back center, the rear ends of the pitmen swinging with the cranks from their centers on the pivots *c*³. The motion of the cranks while the lay dwells, as stated, is shown in dotted lines in Fig. 4.

When the lay is beating up the weft the shuttle should be in one of the boxes *F*, and when thus in its box the swell-finger of said box is pushed by it outwardly against the adjacent arm *E*, causing the shaft or rod *D* so to be turned or rocked as to throw up the arms *C' C'* and elevate the bar *C*, thus making fast or locking the pivoted reed *B*. Should the shuttle, however, at this time be upon the race, instead of in one of the boxes, the arms *E E* will push the swell-fingers into their boxes, the movement of said arms being caused by the rocking of the shaft or rod *D*, produced by the weight of the bar *C* on the arms *C' C'*. Or, in other words, if the shuttle be in its proper place in the box at the time indicated, it will, by preventing the yielding of the swell-finger, and the inward movement of the arms *E E*, hold the bar *C* elevated and keep the swinging reed locked. But if it be not in one of the boxes at that time, the bar *C* will move down by its own gravity, the arms *E* then meeting with no resistance back of the swell-fingers, and the reed will be free to swing back and allow the shuttle to escape. When, however, the shuttle is picked and leaves its box, the bar *C* is then prevented from descending far enough to clear the bottom of the reed, by reason of the anti-friction roller *g'* mounting the cam or swell *H* on the frame *B*² as the lay continues to move back, thus keeping the arms *C' C'* elevated, and the sliding bar *C* sufficiently raised to lock the reed while the shuttle is moving across the race.

When the shuttle does not come home at the right time, the bar *C* slides down and the reed *B* is then free to swing backwardly, thus allowing egress for the shuttle, and avoiding a smash. The downward movement of the bar *C* also leaves the hinged backs *F' F'* of the boxes *F F* free to swing backwardly, thus further facilitating the recession of the shuttle from the race.

The contact of the cams *H* with the roller *g'* has the effect of rocking the shaft *D* in such manner as to cause the arms *E E* to be drawn away from the swells *e' e'*, (which, with my improvements, may be unprovided with springs,) so that when the shuttle is being picked it is not clamped by said fingers, but is free to receive and acquire the full force of the blow or stroke of the picker, and is thus enabled to travel with greater momentum and rapidity, accomplishing a higher number of picks per minute than is possible in looms of the common construction.

The dwell of the lay permits a longer time for the shuttle to come home to its place in the box than if such provision were not made, while at the same time the speed of the crank-shaft is not diminished, nor the number of picks per minute decreased.

I have described the foregoing improvements as applied to a loom having swell-fingers and a protection-rod on the front of the shuttle-box, but they are equally applicable to looms the shuttle-boxes of which have no swell-fingers, but are provided with a protection-rod located in the rear of said shuttle-boxes.

The application of my improvements to looms of this latter construction is illustrated in Figs. 8 and 9, wherein *R* is the protection-rod, sustained in boxes *r r* on the lay-swords *A² A²*, and *S S* are the arms secured thereto, curved or bent at their upper extremities, which enter openings *f f* in the back of the boxes *F F*, so as to impinge against the shuttle. *T* is the sliding bar, which locks the reed, and *U U* the arms, by means of which it is sustained, said arms resting on other short arms *t t*, fast on the protection-rod *R*, the arms *U U* being pivoted in bearings *u u* secured to the front of the race or lay.

The other parts of the loom, notably the arm *R¹* with roller *r¹* and cam *R²*, with the modifications just described, will be substantially the same as those first above mentioned, and the operation will produce the same results as those already set forth—namely, the reed will be locked when the shuttle is properly moving across the race, and when said shuttle comes home at the right time to its place in the boxes, while said reed will be released by the downward movement of the sliding bar, and allowed to swing back for the escape of the shuttle, if the latter does not come home or reach its place in the boxes at the proper time.

For heavy looms, an additional shaft, *V*, having a gear-wheel, *v*, meshing with the pinion *L'* on the crank *L*, may be employed.

When the shaft *V* is employed, the pulley *v'* thereon for the driving-belt may be but half the size of that usually employed on the crank-shaft *L*—as, for instance, where a pulley twenty inches in diameter has been employed on said shaft *L*, one of but ten inches diameter need be used on the supplemental shaft *V*. This will give, say, twice the ordinary speed to said shaft *V*—*i. e.*, twice the ordinary speed of the crank-shaft—and correspondingly quicken the shipping of the running belt onto the pulley *v*. This will insure the almost instantaneous starting of the loom by the power used for driving it, and dispense with the weaver's assisting said starting by hand, as has been heretofore found necessary. So, too, as there is no "banging" with a loom of this construction, and as the unshipping of the belt, owing to the small size and rapid motion of the pulley *v*, is almost instantly effected, all backlash is avoided. In every case the shaft *V* should be geared so as to move much faster—*i. e.*, make more rev-

olutions per minute—than the crank-shaft L; in practice, I should say, three to four times as fast as the latter.

A further object of my invention is to prevent the shuttle from flying out at the front of the loom, breaking the yarn or warp, and endangering the life and person of the weaver. This part of my invention consists in the provision of a bar, which rests upon the yarns, above the race, in such a position as to prevent the shuttle from flying out front, said bar being so arranged and operated that it will be in the described position while the shuttle is being picked and moving across the race, but will be lifted up from the yarns, so as to leave free access to the latter by the weaver when the shuttle is resting in the box.

In Figs. 11 and 12 of the accompanying drawings, W represents a bar parallel with the race, and sustained upon two curved arms, *w w*, which are secured to a rock-shaft, W', having bearings in or upon the swords A². *w*² is an arm, having at one end an eye or collar, *w*³, and set-screw *w*⁴, by means of which it is secured to the shaft W', and at the other end an anti-friction roller, *w*⁵. *w*⁶ is another arm, rigidly secured to the shaft W', and X is a spiral spring, (or a weight may be employed instead,) fastened to said arm, and to one of the swords A² at *x*. The object of this spring is to keep the shaft W' in such a position that the bar W will be held elevated from the yarns when not depressed by the means now to be described.

Y is a cam or eccentric on the shaft L, and Z a lever pivoted at *z* to the frame-piece B², and extending forwardly so as to rest on said shaft L. The forward end of said lever is rounded, as shown at *z'*. When the lay moves back, the roller *w*⁵ meets the lever Z and rides upon it, said lever being then raised by the cam or eccentric Y on the shaft L. This causes the shaft W' to be rocked and the bar W to be lowered upon the yarns. The shuttle is now picked, the bar W remaining in the lowered position, just described, until the shuttle has crossed the race. By the time the shuttle has passed over the race the cam Y has moved from under the lever Z, allowing the latter to fall and the shaft W' to be rocked under the

influence of the spring or weight X, causing the bar W to be raised from the yarns and out of the way of the weaver, if he wish to obtain access to said yarns. Before every pick the bar W is lowered, and after every pick it is elevated, as described.

I have illustrated the parts just described and shown in Figs. 11 and 12 as in position for operation when the pick is made with the crank on the lower center; but said parts may be arranged to operate in the same manner and with like results when the shuttle is picked with the crank on the upper center, by placing the cam or eccentric Y on the opposite side of the shaft L—*i. e.*, diametrically opposite the position shown.

What I claim as my invention is—

1. The combination of the lay-cap A¹, having groove *a*, the removable reed B, and retaining-slide *a*¹, substantially as described.

2. In combination with the pivoted or swinging reed B, the bar C, sustained upon arms C' C', rock-shaft or rod D, arms E G, swells *e*, and cam H, the several parts being constructed and arranged substantially as described, whereby the reed is locked and the swell-fingers relieved upon the back-stroke of the lay, and the locking device is, upon the beat up, placed under the control of the box-swell, as and for the purpose specified.

3. The bar W, located above and parallel with the race, and adapted to be moved down to rest upon the yarns, as and for the purpose described, in combination with the shaft W', curved arms *w w*, lever *w*², and a cam for actuating said bar, as set forth.

4. In combination with the bar W, the shaft W', having arms *w*, *w*², and *w*⁶, spring or weight X, lever Z, and shaft L, having cam or eccentric Y, the several parts being constructed and operating substantially as shown and described.

In testimony that I claim the foregoing I have hereunto set my hand this 24th day of April, 1877.

WILLIAM RIDING.

Witnesses:

GEO. C. SHELMEKDINE,
M. DANL. CONNOLLY.