

T. THORN.
Shutter-Bower.

No. 198,166.

Patented Dec. 11, 1877.

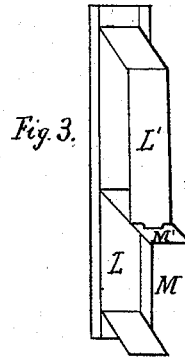
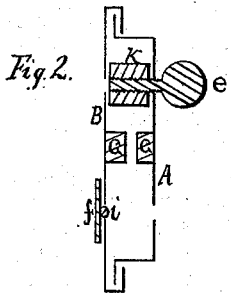
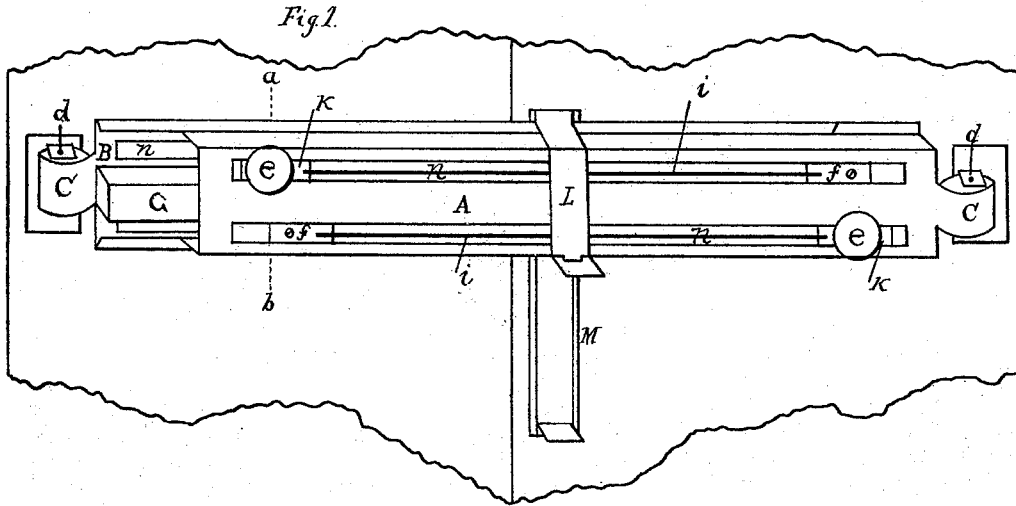

WITNESSES:

John Marshall.
Charles G. Elliott.

INVENTOR:

Theodore Thorn
By Anaco B. M. Coole.
attorney

UNITED STATES PATENT OFFICE.

THEODORE THORN, OF ST. CLAIR, PENNSYLVANIA, ASSIGNOR OF ONE-HALF HIS RIGHT TO MATTHEW S. STOCKER, OF SAME PLACE.

IMPROVEMENT IN SHUTTER-BOWERS.

Specification forming part of Letters Patent No. **198,166**, dated December 11, 1877; application filed February 21, 1877.

To all whom it may concern:

Be it known that I, THEODORE THORN, of St. Clair, in the county of Schuylkill and State of Pennsylvania, have invented a new and useful Improvement in Shutter-Fasteners, which improvement is fully set forth in the following specification, reference being had to the accompanying drawings.

The object of my invention is to provide a shutter-fastener which will secure and fasten a pair or set of shutters or double doors, so that they cannot be opened from the outside, and also hold them securely open, either partly or fully, as may be desired, which object is attained by the use, in novel combination, of two sliding bars, with suitable hinges, arms, and fasteners, as shown in the drawings, and hereinafter more fully described and claimed.

Figure 1 shows a front view of the shutter-fastener, in which A and B are sliding bars, A sliding in grooves formed on the edges of B. C C are hinges formed on the ends of the sliding bars A and B, and secured by the pins *d d*, which may be taken out at will. G is a metal guide working against a corresponding guide on A, which is not shown in the drawing, and they may be made part of the sliding bars A and B by casting or riveting them to the bars. They can be made of any width and height, as their only use is to serve as guides and give strength to the bars. *f f* are two small metal plates screwed fast to the shutters, and having one end of the arms *i i* pivoted in them. The other ends of the arms *i i* are pivoted in the metal nut or sliding blocks K K, in which the fasteners *e e* fit, and are either screwed or held by a cam. In each of the sliding bars A and B are two slots, *n n*, in which the nuts K K slide. L and M form a bolt, (shown further and more in detail in Fig. 3,) and is used to lock the shutters after the bars have been fastened.

Fig. 2 is a sectional view through the line *a b* in Fig. 1. The sliding bars A and B, with their slots, are shown, as well as the guides G G, the fastener *e*, with the sliding nut K and metal plate *f*.

Fig. 3 shows the bolt which locks the shutters to the bar, and thus further secures the fastening of the shutters beyond the fastening

by the bar alone. It is composed of two parts, L and M. L is the bolt proper, which slides in grooves formed by bending over the edges of a portion of M at M', forming a staple, in which a part of L at L' fits and enters, inclosing the shutter-fastener, as shown in Fig. 1.

To operate the fastener it is only necessary to raise the bolt L, then loosen the fasteners *e e*, and push the shutters open. The bars *i i*, which act as arms, will extend out, but, being pivoted to the shutter at *f* and to the sliding nut at K, they serve to form a connection between the shutters and the sliding bars A and B, which, being fastened to the shutters at C by means of hinges, slide in each other as the shutters are opened or closed; and as the shutters are moved the nut K also slides in the slots in the bars A and B. When the shutters are wide open or are opened as far as desired, it is only necessary to adjust the fasteners *e e*, and the shutters will be held firmly in place.

From the foregoing it will be plainly observed that both or any one of the shutters may be held open and fastened at any angle desired, and also that the fastener will work as well on folding shutters or double doors as it will on a single pair of shutters, as the only thing requisite for its operation is the proper fastening of the hinges C and plates *f f* to the shutters. They may be made of cast or sheet metal, and of any design to suit the fancy of the party using them, and if applied to the shutters, as here explained, they will effectually prevent the rattling of the shutters when the wind is high.

I claim as my invention—

The combination, in a shutter-fastener, of the slotted sliding bars A and B, the hinges C C, the metal plates *f f*, and the sliding nuts K K, working in slots in the bars A B, the fasteners *e e*, the guides G G, the pivoted connecting bars or arms *i i*, the pins *d d*, and the bolt L M, substantially as hereinbefore described, for the purpose set forth.

THEODORE THORN.

Witnesses:

CHARLES J. ELLIOTT,
MORGAN REED.