

C. BRINTON.  
Furniture-Casters.

No. 198,186.

Patented Dec. 18, 1877.

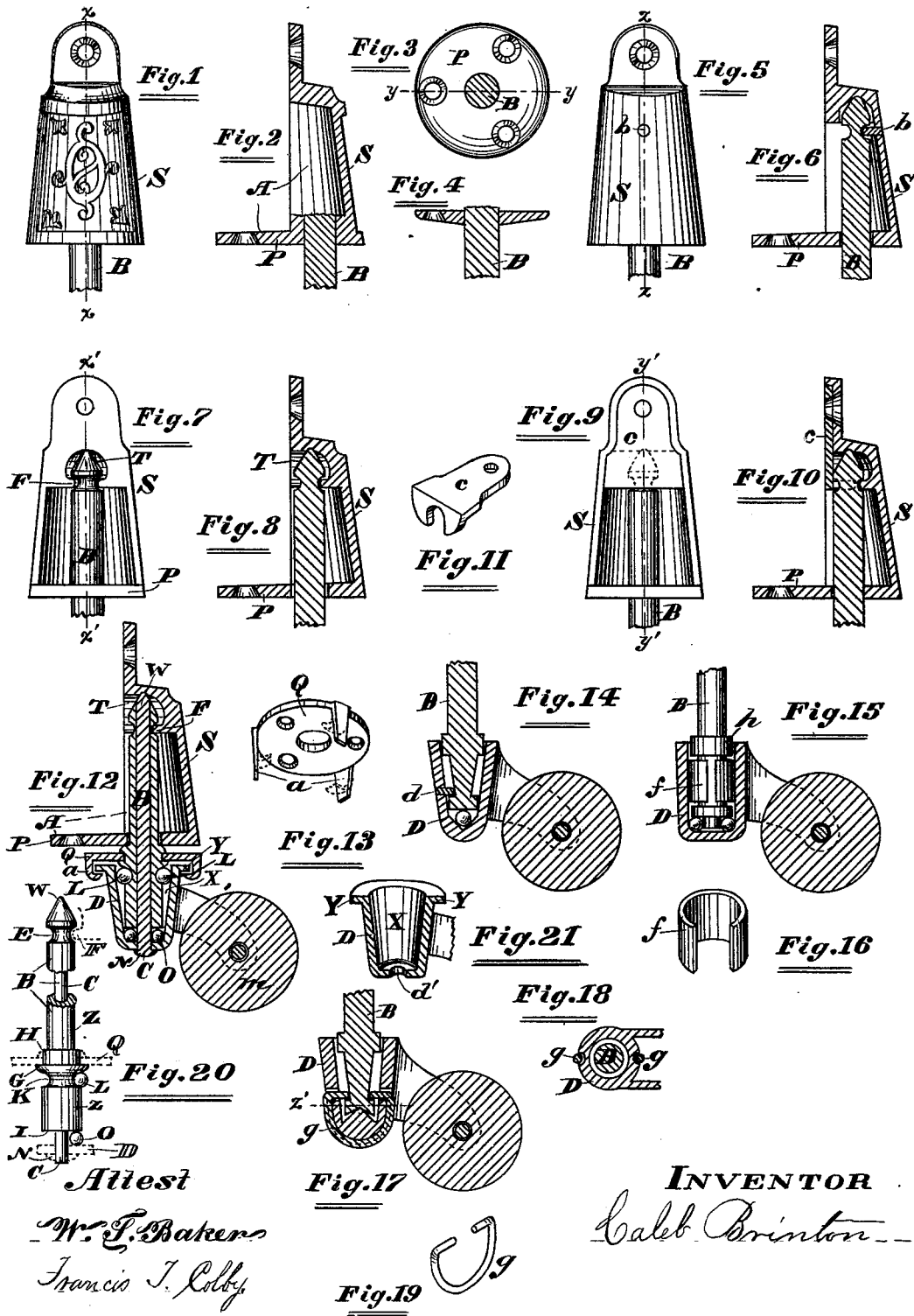

Attest  
W. J. Bakers  
Francis J. Colby

INVENTOR  
Caleb Brinton

# UNITED STATES PATENT OFFICE.

CALEB BRINTON, OF CHICAGO, ILLINOIS.

## IMPROVEMENT IN FURNITURE-CASTERS.

Specification forming part of Letters Patent No. **198,186**, dated December 18, 1877; application filed March 26, 1877.

*To all whom it may concern:*

Be it known that I, CALEB BRINTON, of the city of Chicago, county of Cook, and State of Illinois, have invented a new and useful Improvement in Furniture-Casters, which improvement is fully set forth in the following specification, reference being made to the accompanying drawings.

My invention pertains to that class of articles generally known and designated as "furniture-casters." Among my main objects are, to obviate largely the friction pertaining to most of the casters now in use, and also to make a cheaper caster of the same or better quality; and to these ends my invention consists in a novel construction and combination of parts, as hereinafter more fully described and claimed.

Figure 1 gives a front view of the plate of my caster, which is attached to the side or bottom of the article of furniture. S is the upright or vertical part of the plate, that is attached to the side of the article of furniture, the horizontal part of the plate not being seen in this figure. B is the pintle, broken off, to which is attached the horn of the caster, described farther on.

Fig. 2 shows a sectional view made on the line  $x x$ , Fig. 1, in which appears the horizontal part P of the plate A, as well as the vertical part S of the plate A, and the broken-off part of the pintle B, the letter A being designed to represent the plate of the caster composed of the two parts P and S.

Fig. 3 is designed to represent the portion P of the plate A in Fig. 2, with the portion S of the plate A left off, the plate P, when used thus alone, being of a circular or other suitable form, designed to be placed under the article of furniture.

Fig. 4 is a section on the line  $y y$  of Fig. 3.

Fig. 5 is also a front view of the plate A, the portion P of the plate A not being seen in this view.  $b$  is a dowel-pin projecting a short distance inside of the plate, and into the grooved neck or recess in the pintle, near the top of the same.

Fig. 6 is a vertical section on the line  $z z$ , Fig. 5. In this figure, S is the upright portion of the plate; P, the horizontal portion of the plate;  $b$ , the dowel-pin projecting into the

neck or recess in the top of the pintle. B is the pintle.

Fig. 7 shows a back view of the plate of my caster, in which I may substitute the shoulder F in the place of the dowel-pin  $b$ . In this figure, B represents the pintle of the caster; S, the upright plate of the caster; F, the shoulder fitting into the neck or recess in the pintle, near the top of the same, T being the head of the pintle.

Fig. 8 shows a sectional view on the line  $x' x'$ , Fig. 7, W being the head of the pintle, S the upright plate, and P the horizontal plate.

Fig. 9 gives a back view of my caster, showing the upright portion of the plate S and the pintle B. In this figure I substitute the claw-plate  $c$  for the shoulder F (shown in Fig. 7) and the dowel-pin  $b$  (shown in Fig. 6.) This claw-plate  $c$  rests with the claw portion of the same straddling the pintle, the claw resting in the groove or recess E in the pintle, near the top of the same. The construction of this claw-plate is seen more fully in Fig. 11. This claw-plate is held in position in the plate S by means of a screw fastening the claw-plate  $c$  and plate S onto the article of furniture.

Fig. 10 is a vertical sectional view on the line  $y' y'$ , Fig. 9, in which P shows the horizontal portion of the plate, S the upright portion of the plate, and  $c$  the claw-plate straddling the pintle-neck.

Fig. 11 is a detached view of claw-plate  $c$ .

Fig. 12 gives a view of the face of a vertical section of my caster, in which A is the plate of the same, P is the horizontal portion of the plate, and S the vertical portion of the plate A; F, the shoulder resting in the neck or recess E in the pintle, near the top of the same. W is the head of the pintle, and T is a cavity in which the head of the pintle rests. B is the pintle. Q is a plate attached to the pintle, and having its edges turned down and clasped under the flange on the top of the horn, thus securing the horn to the pintle.  $a$  are lips or downward projections on this plate Q, that are turned down under the flange on top of the horn. Y is the flange on the top of the horn. L are balls resting in a groove in the pintle, to prevent lateral friction of the inside of the horn against the pintle. D is the horn of the

caster, into which the lower end of the pintle is secured. C is the wrought interior portion of the pintle B, with the head N formed or secured on the same, the head N securing the pintle in the horn D. O are balls, on which the shoulder I of the pintle B rests. These balls obviate both vertical and lateral friction of the pintle against the side and bottom of the horn D. *m* is the wheel of the caster, attached to the horn of the same.

Fig. 13 represents a plate, Q, that is attached to the pintle of the caster, with the lips or downward projections *a* of the plate Q turned down under the flange Y on top of the horn D, securing the pintle B to the horn D.

Fig. 14 shows a vertical sectional view of the pintle and horn of my caster, in which I may substitute the dowel-pin *d* in place of the plate Q, (shown in Figs. 13 and 12,) and in which I may dispense with the balls L, and use in the place thereof an annular protuberance on the circumference of the pintle B. I may also substitute for the balls O the single ball under the bottom of the pintle, the single ball resting in the bottom of the horn D. This Fig. 14 is only designed to represent a substitute form of my caster, and is meant to show what may be regarded as substitutes for certain important parts and features of my casters—as, for instance, substituting the annular protuberances on the circumference of the pintle for the balls L, and substituting the dowel-pin *d* in place of the plate Q, and substituting the single ball in the bottom of the horn D in place of the circle of balls O, as shown in Figs. 12 and 20.

In Fig. 15, *f* is a clasp-ring surrounding the pintle B, and lying between the annular protuberance around the same near the top of the horn and the similar protuberance near the bottom of the horn, the outer portion of the clasp-ring *f* pressing with such friction against the inside of the horn D as to be with great difficulty withdrawn therefrom, thus holding the pintle B securely in the horn D. The pintle B freely revolves inside of the clasp-ring *f*.

Fig. 16 gives a perspective top and side view of the clasp-ring *f*.

Fig. 17 is designed to show other substitute devices for various parts of my caster, *g* being a spring-ring, with the two ends of the same bent inward toward the center, these ends being sprung into the holes in the side of the horn D, and resting above the shoulder near the bottom of the pintle B, thus holding the pintle B securely within the horn D, allowing the pintle B to revolve freely within the horn D. The spring-ring *g* is seen more fully in Fig. 19.

Fig. 18 is a top sectional view on the line *z'*, Fig. 17, in which D is the horn, B the pintle, and *g* the spring-ring.

Fig. 19 is a detached view of spring-ring *g*.

Fig. 20 is the pintle of my caster, constructed with the head W, the groove E, the pintle proper B, the shoulder H, the shoulder G, the groove K, the shoulder I, the wrought inte-

rior pin C, and the head N, secured or formed on the wrought interior pin C. Z is the exterior shell of the pintle B, cast around the interior wrought portion C of the pintle B. In this Fig. 20, F is the shoulder on the plate of the caster, resting in the groove E, formed in the pintle B near the top of the same. Q is a plate resting on the shoulder G, being secured thereon by riveting down on the plate Q the shoulder H of the pintle B. L represents a circle of balls resting in the groove K, made in the circumference of the pintle B. These balls obviate the friction of the pintle B against the inside of the horn D. O is a circle of balls resting under the shoulder I of the pintle B. These balls obviate the vertical friction of the pintle against the bottom of the horn D, and also the lateral friction of the pintle B against the side of the horn D.

Fig. 21 shows a front vertical sectional view of the horn D of my caster, X being a cavity in the same, in which the pintle B works, *d'* being a hole through the bottom of the horn D, through which the wrought interior pin C of the pintle B passes, on which the head N is secured or formed that secures the pintle B in the horn D. D is the horn. Y is the flange on top of the same, beneath which the lips *a* of the plate Q (seen in Fig. 13) are clasped, which secure the pintle B to the horn D.

In order to facilitate the securing of the pintle B in the horn D, I make the interior of the pintle B of a piece of wrought metal, on which can be easily formed a rivet-head, N; and in order to make this pintle B as cheaply as possible I cast the exterior Z of the same in the form of a shell around the wrought interior C just above mentioned. The casting of this exterior enables me to readily, easily, and cheaply form the shoulder I, the groove K, shoulder G, shoulder H, groove E, and the head W.

The cavity X in the horn D is made flaring or tapering, in order to facilitate casting. The plate Q, Fig. 13, can be struck out with a die, as also can the plate *c*, Fig. 11.

Reference to Fig. 12 will give a full understanding of the working of the caster, wherein it will be seen that the head W of the pintle B is conically-shaped, thus presenting a very small bearing, and creating but little friction. The bearing of the plate A on the pintle B being at the point W, the plate A does not rest on or touch the plate Q. The pintle B is secured to the horn D by either or both plate Q and rivet-head N. The balls L obviate the lateral friction of the pintle B against the inside of the horn D. The balls O obviate the vertical and lateral friction of the pintle B against the inside and bottom of the horn D.

What I claim as new and as my invention, and wish to secure by Letters Patent, is—

1. The pintle B, constructed with the wrought interior pin C, cast exterior Z, shoulder I, groove K, shoulder G, shoulder H, neck or recess E, head W, and rivet-head N, all sub-

stantially as shown and described, for the purpose set forth.

2. The plate A, constructed with the vertical part S, the horizontal part P, the cavity T, and the shoulder F, all substantially as shown and described, for the purpose set forth.

3. The combination of the plate A, having a vertical face part covering the pintle, with the pintle B, substantially as shown and described, for the purpose set forth.

4. The horn D, constructed with the flange or shoulder Y, tapering chamber X, and hole *d'*, in the manner substantially as shown and described, for the purpose set forth.

5. The horn D, in combination with the pintle B, substantially in the manner shown and described, for the purpose set forth.

6. The balls L, resting in a groove of the pintle, and the balls O, on which the shoulder of the pintle rests, in combination with the horn D and pintle B, in the manner substantially as shown and described, for the purpose set forth.

7. The plate A, in combination with the pintle B, horn D, and balls O and L, in the manner substantially as shown and described, for the purpose set forth.

8. The plate Q, having lips or downward projections *a*, in combination with the pintle B and horn D, in the manner substantially as shown and described, for the purpose set forth.

CALEB BRINTON.

Witnesses:

F. J. SEYBOLD,  
HENRY C. STRONG.