

J. T. CRONIN.  
 Knife-Cleaner.

No. 198,278.

Patented Dec. 18, 1877.

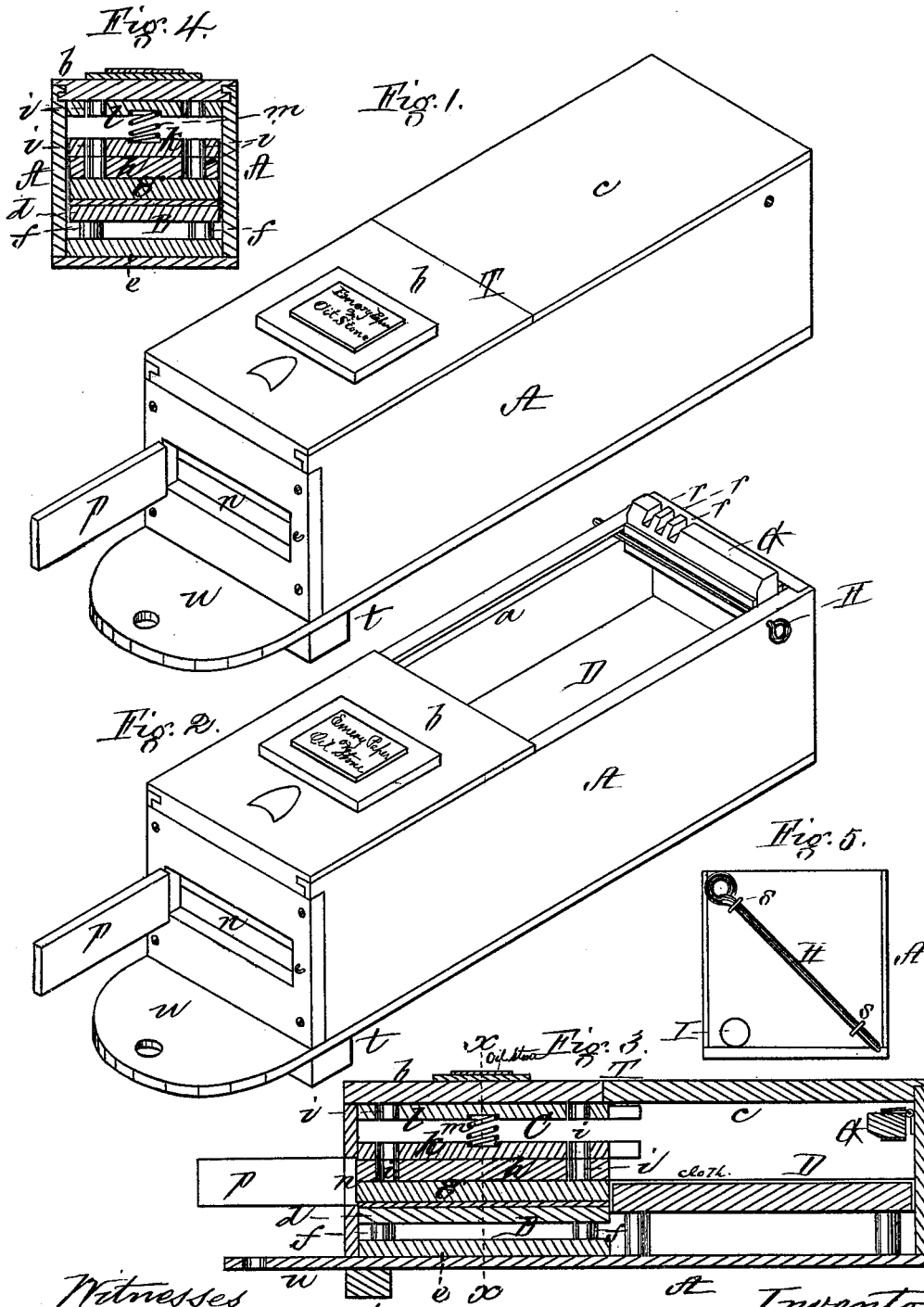

Witnesses  
 W. J. Cambridge  
 J. E. Cambridge

Inventor,  
 John T. Cronin,  
 Per Meschmacher & Stearns,  
 Attorneys.

# UNITED STATES PATENT OFFICE.

JOHN T. CRONIN, OF BOSTON, MASSACHUSETTS.

## IMPROVEMENT IN KNIFE-CLEANERS.

Specification forming part of Letters Patent No. **198,278**, dated December 18, 1877; application filed November 27, 1877.

*To all whom it may concern:*

Be it known that I, JOHN T. CRONIN, of Boston, in the county of Suffolk and State of Massachusetts, have invented certain Improvements in Knife-Cleaners, of which the following is a full, clear, and exact description, reference being had to the accompanying drawings, making part of this specification, in which—

Figure 1 is a perspective view of a knife-cleaner constructed in accordance with my invention. Fig. 2 is a perspective view of the same with the rear portion of its top removed and a device for cleaning forks swung up in place ready for use. Fig. 3 is a longitudinal vertical section through the cleaner, the parts being in the position seen in Fig. 1. Fig. 4 is a transverse section on the line *x x* of Fig. 3. Fig. 5 is a rear elevation.

My invention consists in a box or casing inclosing a pair of rubbers, between which the blade of the knife is moved back and forth in contact with the brick-dust, or other gritty substance employed for this purpose, one or both of the rubbers being made adjustable by one or more springs, whereby they are made to yield and adapt themselves to blades of different thicknesses, a separate rubber, especially designed for cleaning forks, being employed, if desired, and located at one end, or other convenient part of the casing, and being capable of being swung or slid down to admit of its being inclosed by the cover when not required for use.

To enable others skilled in the art to understand and use my invention, I will proceed to describe the manner in which I have carried it out.

In the said drawings, A represents a rectangular box or casing provided with a groove, *a*, near the top of each of its longitudinal sides, for the reception of two portions, *b c*, of a sliding cover, T. Within the front of the box, and resting on its bottom, is a rectangular frame, B, composed of two strips, *d e*, of wood with rubber springs *f* interposed between them, the upper strip *d* having a block of cork, *g*, secured thereto, which forms one of a pair of rubbers, *g h*, between which the blade of the knife, or other instrument, is reciprocated in contact with the brick-dust or other gritty sub-

stance, which is supplied to the rubbing-surfaces through holes *i* formed in a rectangular frame, C, composed of two strips, *k l*, of wood, with a spring, *m*, interposed between them, the upper rubber *h* being secured to the lower side of the strip *k*, and, together with the lower rubber *g*, yielding on the entrance of the blade, the employment of the springs *f m* rendering the rubbers capable of receiving blades of different thicknesses between them. The upper rubber *h* is held down on the lower rubber, against the resistance of its spring *m*, by the portion *b* of the cover T, whereby the necessary friction is produced to clean the blade as it is moved between them. The brick-dust is placed on a platform or shelf, D, located within the rear of the box, and is fed through the holes *i* in the upper rubber and its frame by simply tipping the box down in front, a portion of the brick-dust being carried into the space between the rubbers by the backward movement of the blade, which is entered through an opening, *n*, in the front of the box, a door, *p*, being provided for closing this opening, when desired.

At the upper rear end of and within the box is hinged a transverse strip or block, G, of cork, provided with grooves or recesses *r* for the reception of the tines of a fork, this hinged strip of cork being first swung up by hand, and kept in the position seen in Fig. 2, by a transverse supporting-rod, H, which enters holes in the sides of the casing, the fork-cleaner being swung down within the casing, and the cover being slid into place when not required for use. The supporting-rod H, after being removed from its position beside the fork-cleaner, is placed at the rear end of the casing, between two staples, *s s*. (See Fig. 5.)

I is an opening in the rear end of the box, near one of its lower corners, by which the brick-dust may be emptied from the box, when desired. The under side of the front of the box is provided with a transverse cleat, *t*, which is intended as a stop to bear against the edge of a table, to keep the knife-cleaner in place thereon.

The lower portion of the front of the cleaner is provided with a projection, *u*, having a hole through it, by means of which the cleaner may be hung up on a nail or hook when not in use.

The rubbers *g h* may be of leather, rubber, soft wood, or other suitable material, and one or both of them may be provided with one or more springs, if desired.

Should the holes *i* in the upper rubber become clogged by the brick-dust, it may be readily removed by passing a pin or rod down through the holes *i* in the frame in line with each other.

In order to tighten or better close the joints, and prevent the brick-dust from working out of place, I apply thereto a packing of felt, flannel, or other suitable material.

It is evident that the hinged fork-cleaner may be dispensed with, and the pair of rubbers *g h* be used for this purpose, and a sheet of emery or an oil-stone may be placed on the cover for sharpening knife or other blades, if desired.

What I claim as my invention, and desire to secure by Letters Patent, is—

1. The rubbers *g h*, one or both of which are made to yield to accommodate blades of different thicknesses, the upper rubber being perforated to allow of the passage of the gritty substance, in combination with an inclosing box or casing, *A*, provided with an opening, *n*, for the entrance of the blade, and with a cover, *T*, for holding down the upper rubber *h*, substantially as and for the purpose described.

2. The auxiliary pivoted rubber *G*, held in its working position by a removable rod or pin, *K*, in combination with the inclosing box or casing *A*, substantially as and for the purpose set forth.

Witness my hand this 22d day of November, 1877.

JOHN T. CRONIN.

In presence of

N. W. STEARNS,

P. E. TERSHEMACHER.