

C. G. BREWER.
Apparatus for Generating Illuminating-Gas.
No. 198,340. Patented Dec. 18, 1877.

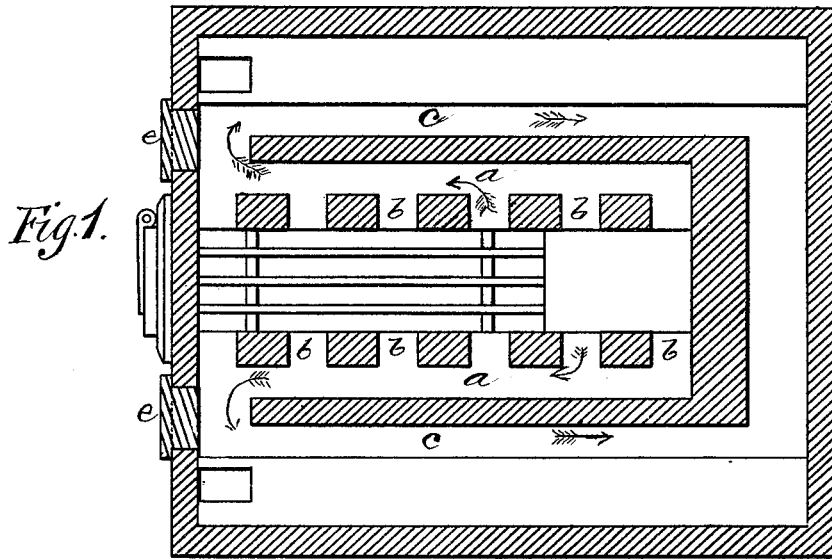
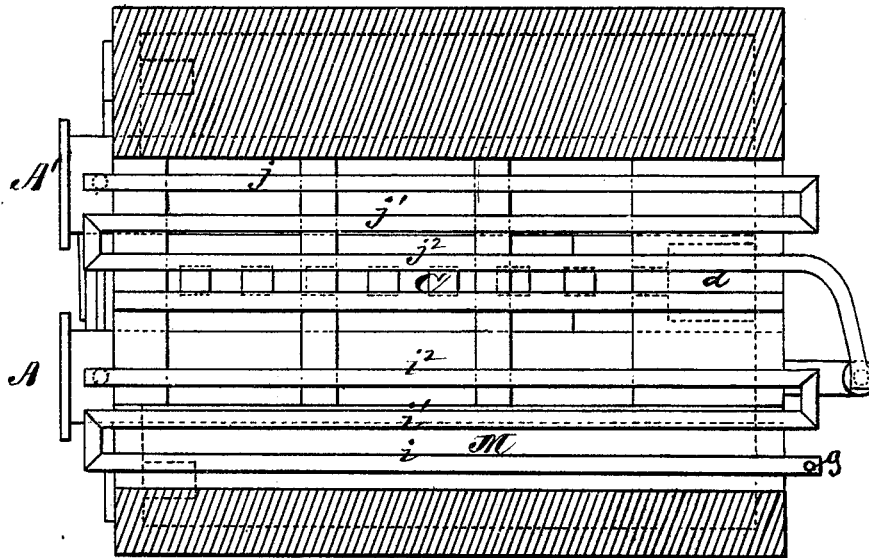

Fig. 2.



WITNESSES
Villette Anderson
G. J. Clasi

INVENTOR
C. G. Brewer,
by E. W. Anderson,
ATTORNEY

C. G. BREWER.
Apparatus for Generating Illuminating-Gas.
No. 198,340. Patented Dec. 18, 1877.

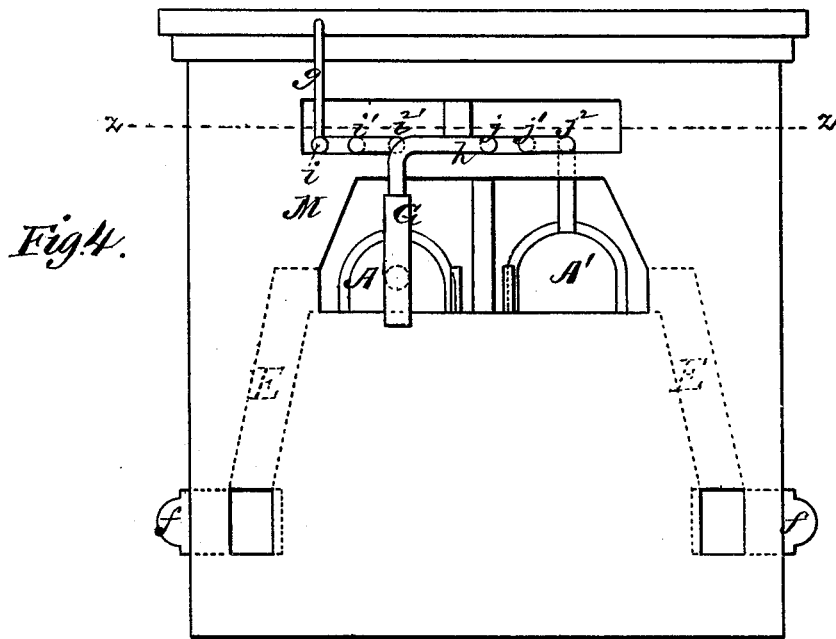
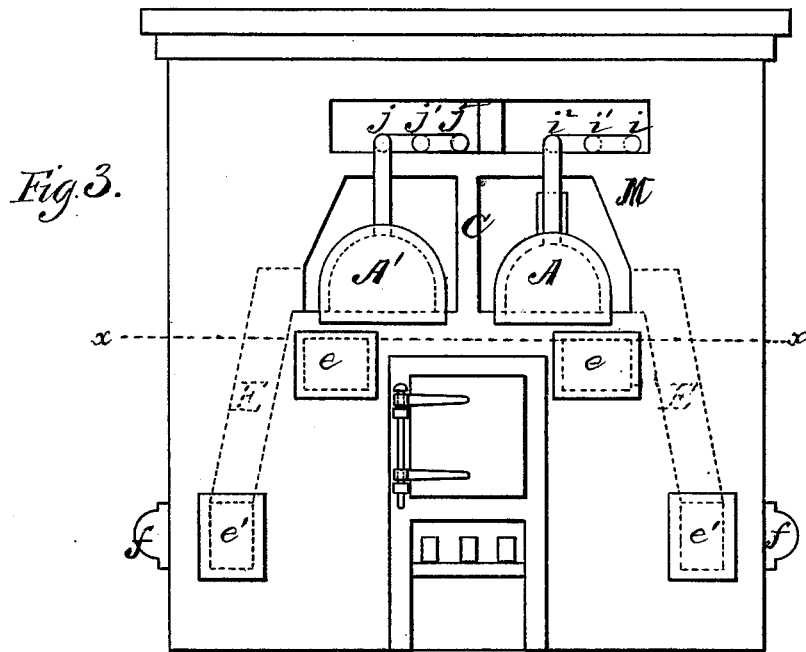

WITNESSES
Villette Anderson
F. J. Massi

INVENTOR
C. G. Brewer,
by *Ell. Anderson,*
ATTORNEY.

C. G. BREWER.
Apparatus for Generating Illuminating-Gas.
No. 198,340. Patented Dec. 18, 1877.

Fig. 5.

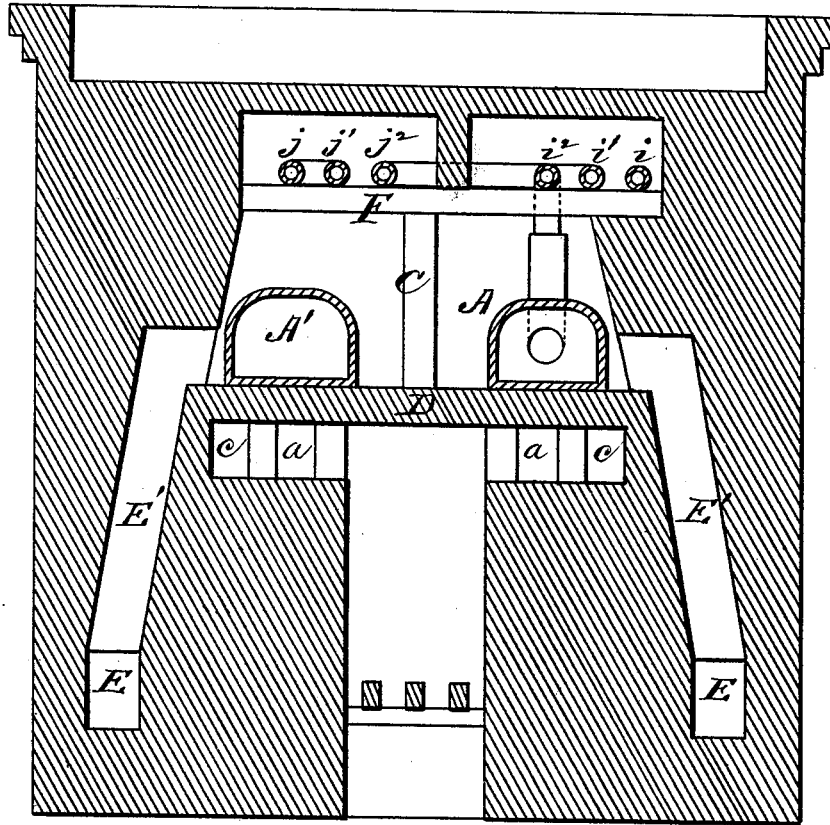

WITNESSES
Villette Anderson
A. J. Jellasi

INVENTOR
C. G. Brewer,
by E. W. Anderson,
ATTORNEY

UNITED STATES PATENT OFFICE.

CHARLES G. BREWER, OF PENN YAN, NEW YORK.

IMPROVEMENT IN APPARATUS FOR GENERATING ILLUMINATING-GAS.

Specification forming part of Letters Patent No. **198,340**, dated December 18, 1877; application filed October 28, 1876.

To all whom it may concern:

Be it known that I, CHARLES G. BREWER, of Penn Yan, in the county of Yates and State of New York, have invented a new and valuable Improvement in Apparatus for Generating Illuminating-Gas; and I do hereby declare that the following is a full, clear, and exact description of the construction and operation of the same, reference being had to the annexed drawings, making a part of this specification, and to the letters and figures of reference marked thereon.

Figure 1 of the drawings is a representation of a horizontal sectional view of the apparatus, taken through line *x x*. Fig. 2 is a similar section taken through line *z z*. Fig. 3 is a front view; Fig. 4, a rear view; and Fig. 5 is a vertical cross-section thereof, showing the protecting-ledge.

This invention has relation to improvements in apparatus for generating illuminating-gas from wood or coal, and for forming a chemically-fixed gas in the union therewith of the vapors of hydrocarbon oils; and the nature of my invention consists in the combination, with a coal or wood retort and a fixing-retort, of a series of connected primary retorts, through which the oil will pass on its way to the main fixing-retort for the oil, and in which it will be subjected to the action of heat, increasing progressively from the oil-induct to its educt into the fixing-retort, whereby the oil will be gradually volatilized, and, on reaching the fixing-retort, will be in proper condition for mixing with the gas generated from the coal-retort, as will be hereinafter more fully explained.

In the annexed drawings, the letters A A' designate, respectively, the oil and the coal retorts, which are arranged in a bench, and separated from each other by an open-work wall, C. These retorts will be made of the usual materials, and will be protected from the direct action of heat by means of a horizontal wall, D, extending entirely across the furnace, and dividing it into two parts. The products of combustion pass from the furnace into a horizontal flue, *a*, surrounding the same, through spaced apertures *b* formed in its side walls. They are then directed to the front, and pass into a second horizontal flue, *c*, surrounding and outside of the first, thence to

the rear, and up a vertical flue or flues, *d*, into the chamber containing the retorts A A' above mentioned.

Access is had to the flues *a c*, for the purpose of keeping them clear of dust and cinders, through doors *e* in the front wall of the furnace.

E E represent lateral flues arranged at each side of the fire-chamber, on the same or nearly the same level as the grate-bars, and extending through the end walls of the furnace. They are closed at their front ends by means of valves or doors *e'*, and in rear by means of dampers *f*, which are adjustable, and communicate with the upper or bench chamber by means of vertical flues E' formed in the furnace-walls, and extending through wall D.

By opening one of the dampers, cold air will be admitted into flue E, pass up flue E', and regulate or lower the temperature on one side of the retort-chamber. The effect of this arrangement is that, if the hydrocarbon gases are being generated in excess of the quantity required for sufficiently enriching the coal or wood gas, by closing the damper on the side of the oil-retort and opening the one on the side of coal or wood retort it will relieve the oil-retort, and at the same time bring up the coal or wood retorts to increased action.

F represents a partition in the upper chamber, made in open or mesh-like form, and supporting the primary oil-retorts *i i'* *i''* and the fixing-retorts *j j'* *j''*, the former being above the fixing-retort A and the latter above the coal or wood retort A'. The oil is passed into the first primary retort, *i*, by a feed-pipe, *g*. It is then carried through a coupling-joint into the second, *i'*, thence through a coupling into the third retort, *i''*, passing through which, it is discharged into the oil-retort A at its front end. The couplings are alternately at one end of the primary retorts and at the other, after the manner of a steam-coil.

When the oil in retort A is volatilized and thoroughly fixed, it passes down a pipe, G, on the rear end of the retort, and, through a connection, *h*, mixes with the carbureted hydrogen generated by retort A' and fixed in retorts *j j'* *j''*, thus forming a chemically-fixed gas of high candle-power.

In order to prevent the carbonization, caking, or thickening of the oil in the primary re-

torts i i^1 i^2 , whereby a great quantity of the illuminating property of the oil is lost and the said retorts are clogged, I have devised the following: Retort i will be arranged directly over a ledge or shelf, M, and will be shielded from the direct action of heat thereby. Retort i^1 will be partly—to the extent of one-half, or thereabout—protected therefrom, and retort i^2 , being outside of the shelf, will be shielded not at all.

The oil, in passing through retort i , will be vaporized only, in passing through retort i^1 still further advanced toward conversion into the bicarburet of hydrogen, and in retort i^2 will reach this stage. Passing thence into retort A, it will be fixed. During the formation of the bicarburet of hydrogen in retort A the carburet of hydrogen will have been formed in the coal or wood retort A' and fixed in the retorts j j^1 j^2 , and will form a chemically-fixed gas, when united at the respective educts of the oil and coal or wood retorts, before passing into the hydraulic main, where the most

of the tar and ammonia are condensed. The condenser and dry-lime purifiers will then relieve the enriched gas of sulphur and the remaining ammoniacal gas, as well as of the pyroligneous acid.

Having described my invention, what I claim as new, and desire to secure by Letters Patent, is—

1. The combination of vaporizing oil-retorts i i^1 i^2 , fixing-retort A, connections G h, wood or coal retort A', and the combining and fixing retorts j j^1 j^2 , substantially as specified.

2. In combination with the retorts A A', the furnace having damper-flues E E', provided with doors $e' e'$, substantially as specified.

In testimony that I claim the above I have hereunto subscribed my name in the presence of two witnesses.

CHARLES G. BREWER.

Witnesses:

D. A. OGDEN,

D. A. OGDEN, Jr.