

W. CAIRNS.
Centrifugal-Machine.

No. 198,346.

Patented Dec. 18, 1877.

Fig. 1.

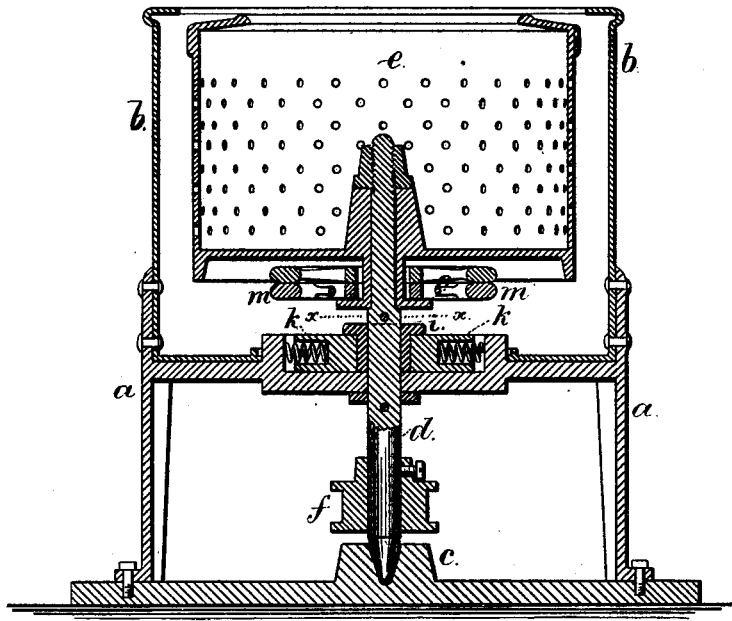

Fig. 3.

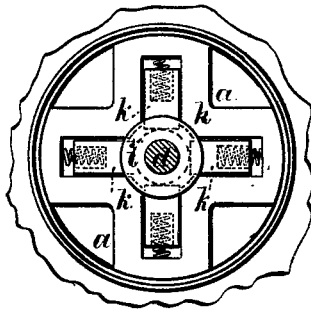
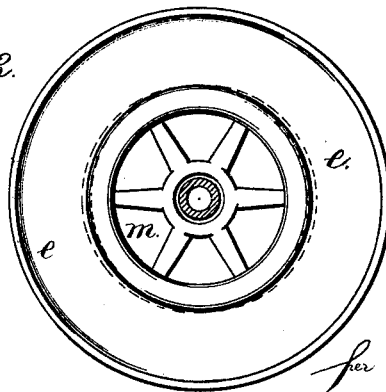

Fig. 2.



Witnesses

Chas. H. Smith
Geo. T. Pinckney

Inventor
William Cairns.
per Lemuel W. Ferrell
att.

UNITED STATES PATENT OFFICE.

WILLIAM CAIRNS, OF JERSEY CITY, NEW JERSEY.

IMPROVEMENT IN CENTRIFUGAL MACHINES.

Specification forming part of Letters Patent No. **198,346**, dated December 18, 1877; application filed October 25, 1877.

To all whom it may concern:

Be it known that I, WILLIAM CAIRNS, of Jersey City, in the county of Hudson and State of New Jersey, have invented an Improvement in Centrifugal Extractors, of which the following is a specification:

Centrifugal driers for sugar and for fabrics have been made and used, both in chemical operations and in dyeing and scouring establishments and in laundries; but in cases where fabrics are put into the revolving perforated cylinder or basket, the weight of such fabrics is very liable to be unevenly distributed, and the centrifugal device does not run true and steady, but wobbles like a top that is heavier at one side than the other.

Centrifugal driers have been made in which the axis is allowed to move so as to accommodate itself to inequalities in the contents of the basket, and the bearings of the axis have been made so as to yield to the movement of the shaft. In this case, however, the inertia of the parts is liable to make the shaft and bearing strike in first one direction and then the other. I make the bearings or sliding boxes with flat ends, and place them in cross or X shaped slides, so that the bushing will be subjected to friction while sliding across between the flat ends of the opposite bearings. This detains the bushing sufficiently to prevent the said striking or thumping action against the opposite spring-bearings as the shaft is revolved.

In the drawing, Figure 1 is a vertical section of the drier. Fig. 2 is an inverted plan of the basket, and Fig. 3 is a plan below the line *x x* of Fig. 1.

The stand or frame *a* supports the curb *b*, and in the center is the step *c* for the vertical shaft *d*, at the upper end of which is the

basket or perforated cylindrical receiver *e*, into which the clothes or other fabrics to be dried are placed. The driving-belt revolves the pulley *f*, shaft *d*, and basket *e*, as usual.

The step *c* retains the lower end of the shaft *d*, but allows it to swing or revolve more or less eccentrically at its upper end, and to allow of this motion the upper bushing *i* of the shaft is not in a rigid bearing, but it is supported between the sliding boxes *k*, that are within cross-slides in the frame *a*, and pressed toward the bushing *i* by springs. These boxes *k* have flat or nearly flat ends next to the bushing *i*, so that the spindle and bushing can move freely, the spindle revolving in the bushing, and the bushing sliding against the ends of the yielding bearings, and allowing the spindle to assume a slight inclined position while revolving, in order that the center of gravity and the axis of motion may correspond; and there is a friction applied to the edges of the bushing *i*, at opposite sides, by the flat ends of these boxes *k*, for the purposes aforesaid.

There are one or more loose wheels, *m*, like horizontal fly-wheels, around the shaft, and supported by the flange *o*, that serve to balance the basket when unequally filled.

I claim as my invention—

The four sliding bearings *k*, each made with a flat or nearly flat end, in combination with the cross-slides receiving such bearings, the springs, the bushing and shaft *d*, and basket *e*, substantially as set forth.

Signed by me this 24th day of October, A. D. 1877.

WM. CAIRNS.

Witnesses:

HAROLD SERRELL,
GEO. T. PINCKNEY.