

A. K. GRIM & J. B. LOW.  
 Combined Overflow-Valve and Gas-Trap for Stationary  
 Wash-Basins.

No. 198,456.

Patented Dec. 25, 1877.

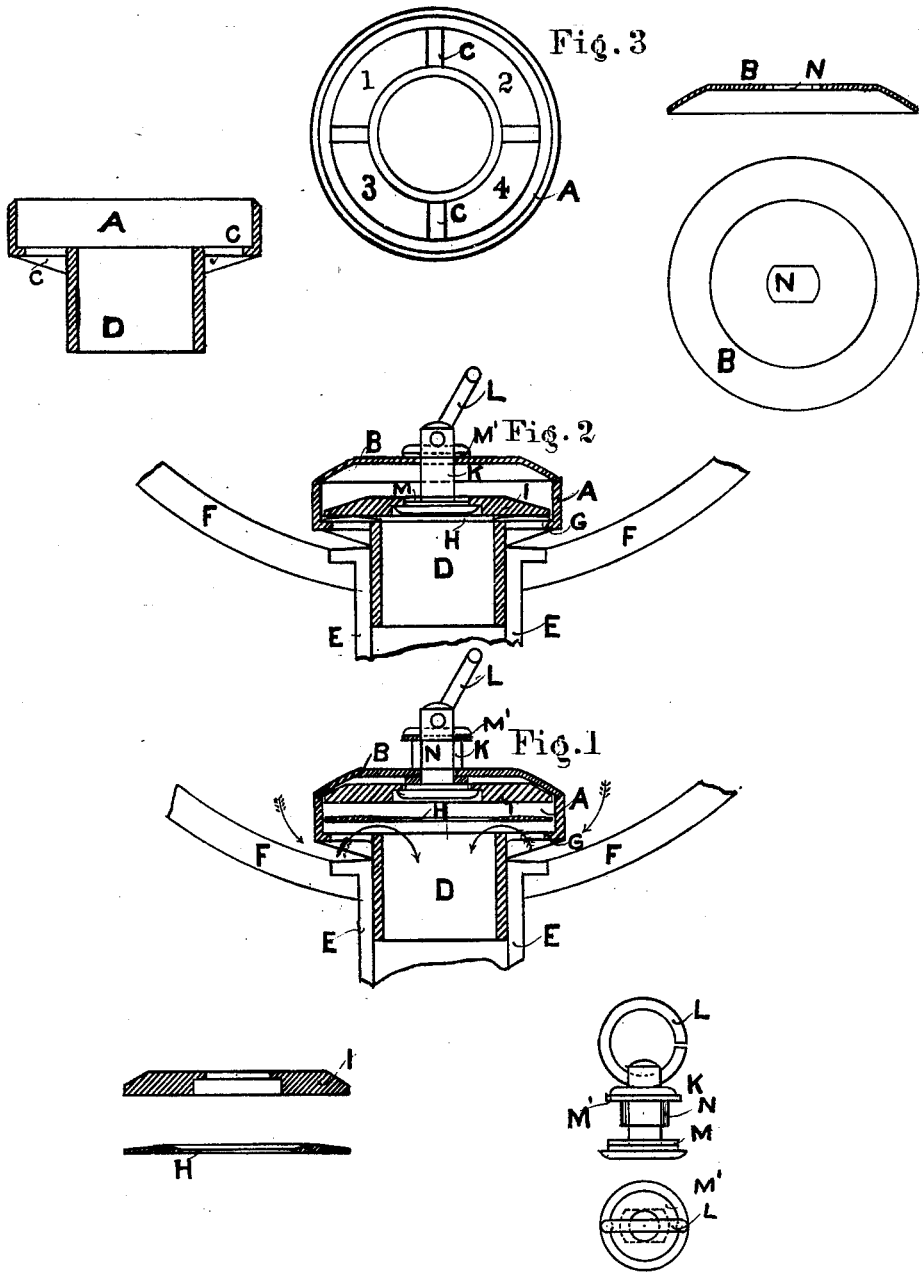

Witnesses

*Geo Pardy*  
*George M. Arthur*

Inventors

*Abraham K. Grim*  
*Joel B. Low*  
*per George Pardy*  
*Att'y*

# UNITED STATES PATENT OFFICE.

ABRAHAM K. GRIM AND JOEL B. LOW, OF SAN FRANCISCO, CALIFORNIA.

IMPROVEMENT IN COMBINED OVERFLOW-VALVE AND GAS-TRAP FOR STATIONARY WASH-BASINS.

Specification forming part of Letters Patent No. **198,456**, dated December 25, 1877; application filed September 19, 1877.

## *To all whom it may concern:*

Be it known that we, ABRAHAM K. GRIM and JOEL B. LOW, both of San Francisco, State of California, have invented a Combined Overflow-Valve and Gas-Trap for Stationary Wash-Basins, of which the following is a specification:

The object of this invention is to insure that the quantity of water contained in the basin shall never exceed a certain limited amount, thus avoiding overflowing the basin, the invention operating to discharge the water automatically when this arranged limit is reached. Also, the invention provides at all times for shutting out the gaseous vapors rising through the pipes connecting with the sewer.

In Figure 1 of the accompanying drawings the invention is shown, in sectional elevation, applied to an ordinary stationary wash-basin as it would appear open at the moment of discharging. Fig. 2 shows the same closed. Fig. 3 is a plan, showing the openings 1 2 3 4.

The detached details are also shown and referred to by letters, as hereinafter mentioned.

The invention consists in a hollow plug intended to be inserted in the mouth of the discharge-pipe that is connected with the bottom of the ordinary stationary wash-basin, within which hollow plug a valve is placed to cover and close the discharge-opening, the valve being held down by a weight resting upon it, the action being such that, while the valve and its weight exceed and overbalance the pressure due to the amount of water in the bowl, the eduction-passage is kept covered, and the water is held in the basin; but when the amount of water is such as to create a pressure upon the exposed area of the under side of the valve greater than is due to the weight of the valve itself and its superimposed counter-balance, then the valve is lifted up, and a free exit for the water is given.

The velocity of the current of the escaping water is sufficient to overcome any tendency the valve has to drop to its seat when, the head of water being reduced by a portion having escaped, the weight and valve might again be supposed to acquire preponderance of pressure, the valve always being held up until all the water has passed out, in this respect acting upon the principle illustrated in any run-

ning stream, where the natural tendency of heavy bodies to gravitate to the bottom is counteracted, to a greater or less extent, by the velocity of the flow. There is also, however, an effect produced by the suction of air as the water recedes down the discharge-pipe, as in practice it is observable that the valve never falls until a moment later than that which marks the passage out of the last drop of water.

In the different figures of the accompanying drawings, A represents the so-called hollow plug, which may be described as being formed of a round bottomless box, with separate cover B, its sides being connected, by narrow arms C, to a short pipe, D, in the center. This pipe projects downward from level with the bottom of the box part of the plug about one inch, and is inserted in the discharge-pipe E of the basin F. The upper end of this pipe, in conjunction with the annular rim G of the box, forms the seat of the valve H, the upper edge of the arms C being a little below the level of this seat, so as to allow the water-pressure to affect as large an area of the valve as possible. The arms C slant downward from the extreme circumference of the plug to the pipe D. The lowest point of the arms resting against the discharge-pipe regulates the height of the exit-passage for the water between the valve-box and the basin. I is the counter-weight, which should be made of metal of great specific gravity, as lead or analogous substance. It has a loose stem, K, passing through its center, and to the outside of the cover B a ring, L, forming a convenient handle to raise and lower it and its attached weight. This stem K is provided with leather or rubber washers M M', to bear against the inside or outside of the cover B as the stem is raised or lowered, the object being to insure against leakage of gas through the hole in the cover. The stem has an oblong cross-section at N, the hole in the cover corresponding, so that, when the stem is raised as to bring this part N above the cover, if it be turned a quarter round, then the long diameter of this part of the stem will cross the short diameter of the hole, and consequently, not being able to drop through, will be held there, and the counter-weight suspended, freeing the valve H below it.

The distance from the lower edge of the part

N of the stem to the face of washer M represents the lift of the stem plus the thickness of the cover B.

It will be seen in the drawings that the upper face of the valve H is slightly beveled. This is to prevent it sticking to the counter-weight, as it might do if made perfectly flat.

The cover B is made rounding to shed the water, and is secured to the body of the plug by overlapping the edge of the box part over the edge of the cover.

From the foregoing it will be understood that the weight I and valve H must be adjusted, as to their weight, to exactly counterbalance the extreme head of water to be supplied to the basin.

The object of not combining the valve and its counter-weight is to insure a covering for the openings 1 2 3 4 when the counter-weight is raised and held suspended by lifting the stem K, and holding it at its highest point, by the means heretofore described.

It will be seen that the gases would escape from the sewer into the atmosphere if the valve were so arranged as to be permitted to be left suspended above its seat.

When it is desired to empty the bowl, the ring L is pulled up, a quarter-turn made, the plug left in that condition, and the water will all run out. When the bowl is again to be filled, another quarter-turn is made, and the stem dropped so as to rest the counter-weight on the valve. The basin may then be filled to any desired height below the arranged limit, which may be marked on the bowl.

With this device attached to the bowl there is no possibility of gas escaping from the sewers into the surrounding atmosphere.

What we claim as our invention, and desire to secure by Letters Patent, is as follows:

The combination of the valve H, counter-weight I, and its stem K with the valve-box or hollow plug A, constructed and operated substantially as described.

ABRAHAM K. GRIM.  
JOEL B. LOW.

Witnesses:

GEORGE PARDY,  
JAMES H. GRAHAM.