

P. F. JOUTE & C. F. BERNARD.
Motor.

No. 198,461.

Patented Dec. 25, 1877.

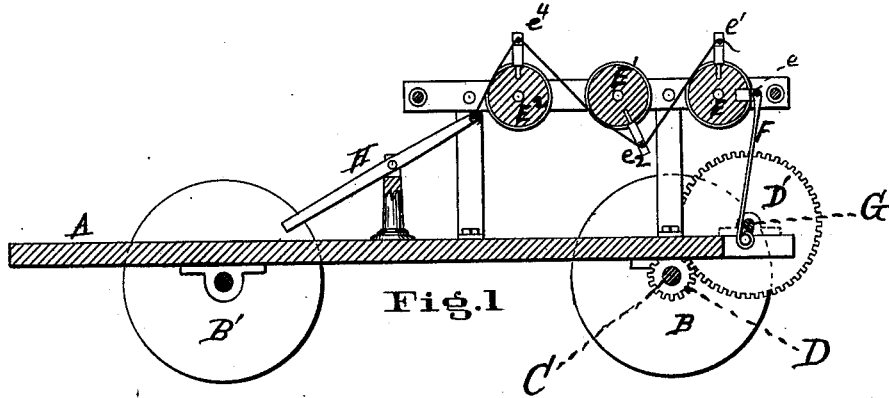

Fig. 1

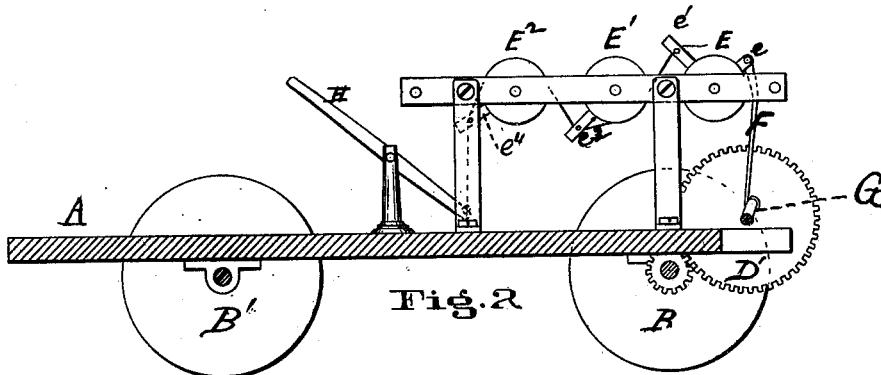

Fig. 2

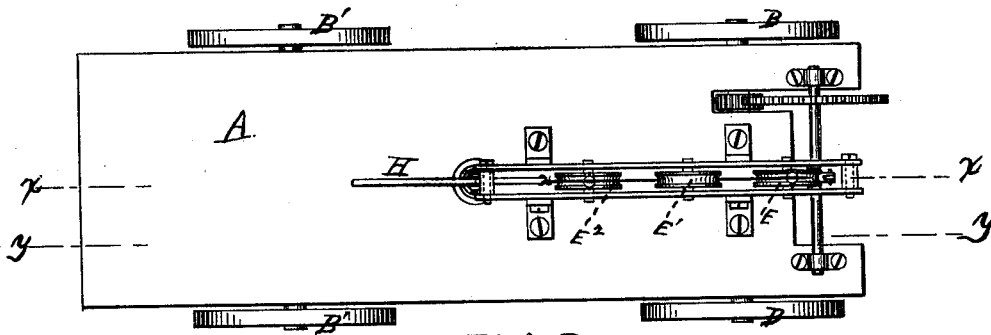

Fig. 3

Attest
Chas. H. Gessert,
Arch. V. Stewart,

Inventors
Pierre F. Jouté
Charles F. Bernard.

UNITED STATES PATENT OFFICE.

PIERRE F. JOUTE AND CHARLES F. BERNARD, OF CINCINNATI, OHIO.

IMPROVEMENT IN MOTORS.

Specification forming part of Letters Patent No. **198,461**, dated December 25, 1877; application filed November 9, 1877.

To all whom it may concern:

Be it known that we, PIERRE F. JOUTE and CHARLES F. BERNARD, of Cincinnati, in the county of Hamilton and State of Ohio, have invented certain new and useful Improvements in Hand-Motors; and we do hereby declare that the following is a full, clear, and exact description thereof, which will enable others skilled in the art to which it appertains to make and use the same, reference being had to the accompanying drawings, and to letters of reference marked thereon, which form a part of this specification.

In the drawing, Figure 1 is a section taken in line *x* of Fig. 3. Fig. 2 is a section taken in line *y* of same, and Fig. 3 is a plan of our invention.

The drawing represents our invention as adapted to a hand-car, but can be used for all purposes where hand-power is to be applied.

In construction our invention is as follows: A is the platform, resting on the two driving-wheels B B and bearing-wheels B' B'. The drivers are attached to the axle C, which has also permanently fastened to it the pinion D, engaging in the gear-wheel D'. Above the platform is a frame carrying a series of oscillating grooved pulleys, E E¹ E². The pulley E has a stud, *e*, in its periphery, which, with pitman F, forms a joint. The pitman engages, with the other end, with the crank G on the shaft carrying wheel D'. Another stud, *e*¹, is inserted in the pulley E, at right angles with *e*. A cord or wire-rope begins at stud *e*¹, passes under the pulley E¹, and is attached to another stud, *e*², fastened to E¹; thence to another stud, *e*⁴, attached to E², and finally made fast to the oscillating lever H. The long arm of this lever is the handle where power is applied by hand.

In operation our invention is as follows: When the operator raises the handle or long arm, the short arm of lever H descends, as seen in Fig. 1, drawing the cord downward. As the stud on E² is vertical, its power increases on its descending. The power of pulley E¹ also increases, as well as that of E. Thus a great gain of power is attained. The power at length (after passing through the several pulleys) acts against the crank, and thus transmits its power to the gear-wheel D' and the drivers B B. When the lever-handle is in the position seen in Fig. 2, the momentum of the machine causes the crank to descend, and, by the intervening cord, brings the lever into the position seen in Fig. 1, where the power can be again applied, as before mentioned.

In practice it may be found best to attach a double set of studs just opposite to those shown in the drawing, and, by attaching the cord connecting them to the opposite arm of lever H, a double or reciprocating stroke is obtained.

Having thus described our invention, what we claim, and desire to secure by Letters Patent, is—

1. A series of oscillating pulleys, E E¹ E², connected together, as described, to transmit motion from lever H to pitman F, as set forth.

2. The arranging of the studs *e*¹ *e*² *e*⁴ in such relative position as to give an increase of power, as specified.

In testimony that we claim the foregoing as our own we affix our signatures in presence of two witnesses.

PIERRE F. JOUTE.
CHARLES F. BERNARD.

Witnesses:

A. V. STEWART,
CHAS. F. GESSERT.