

# A. F. STOWE. Leather-Rolling Machine.

No. 198,473.

Patented Dec. 25, 1877.

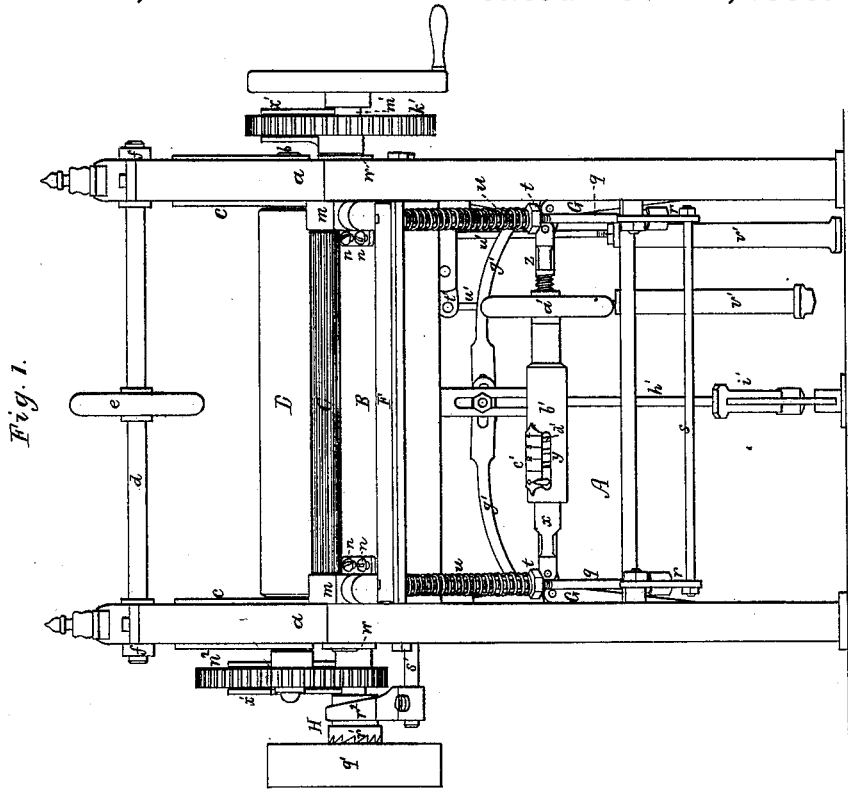

Fig. 1.



Fig. 6.

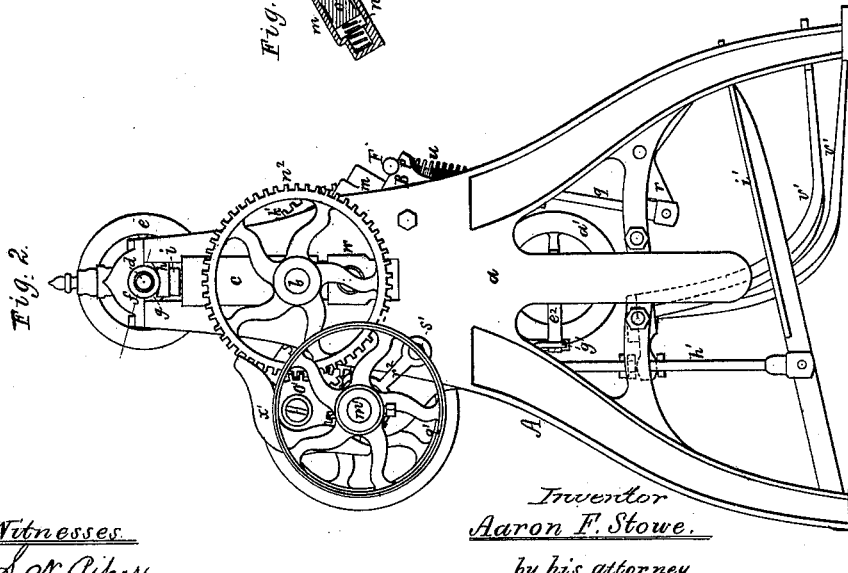

Fig. 2.

Witnesses  
*S. M. Piper*  
*G. Schmitt*

Inventor  
*Aaron F. Stowe.*  
 by his attorney  
*R. H. Eddy*

# A. F. STOWE. Leather-Rolling Machine.

No. 198,473.

Patented Dec. 25, 1877.

Fig. 4.

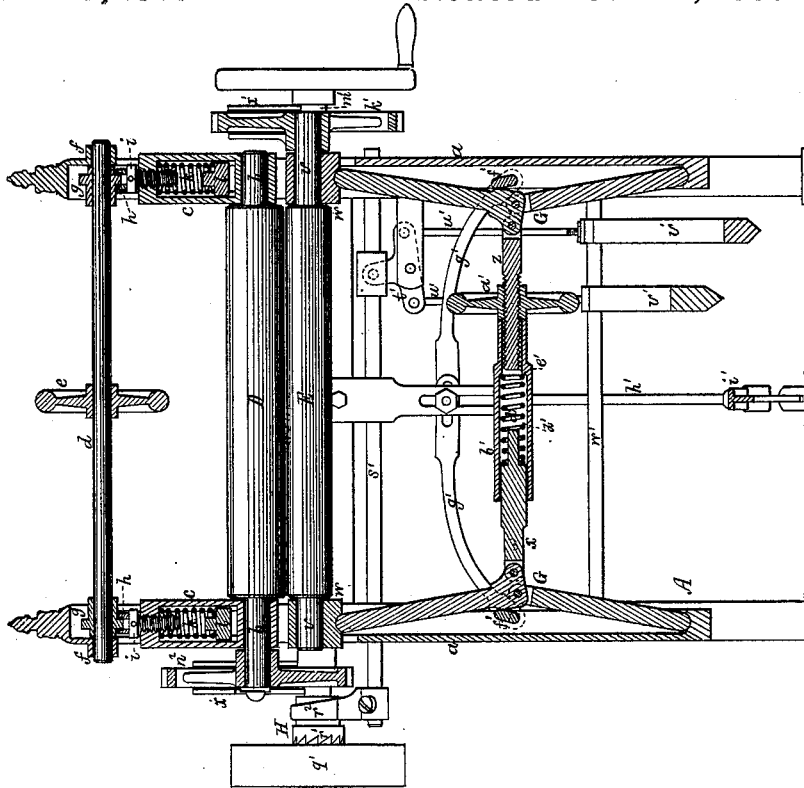

Fig. 5.

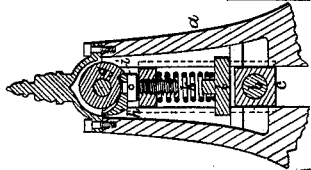
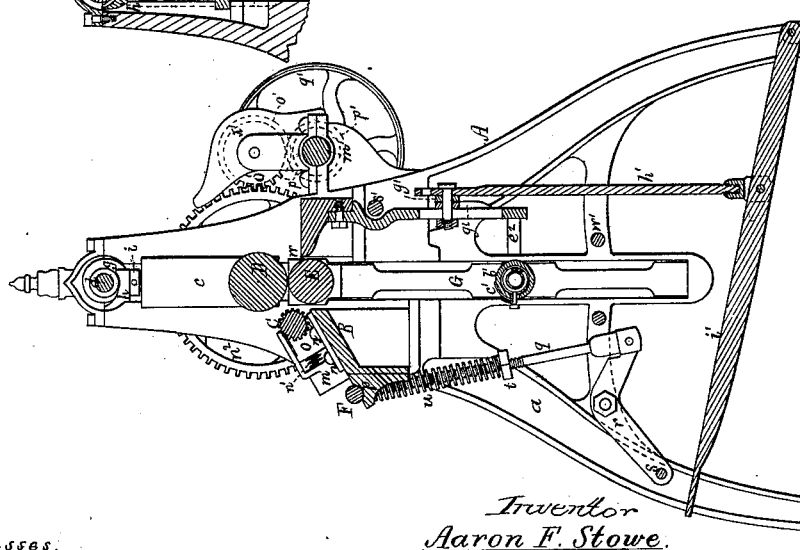

Fig. 3.



Witnesses:  
*L. W. Piper*  
*L. W. Miller*

Inventor  
*Aaron F. Stowe.*  
 by his attorney  
*R. W. Eddy*

A. F. STOWE.  
Leather-Rolling Machine.

No. 198,473.

Patented Dec. 25, 1877.

Fig. 7

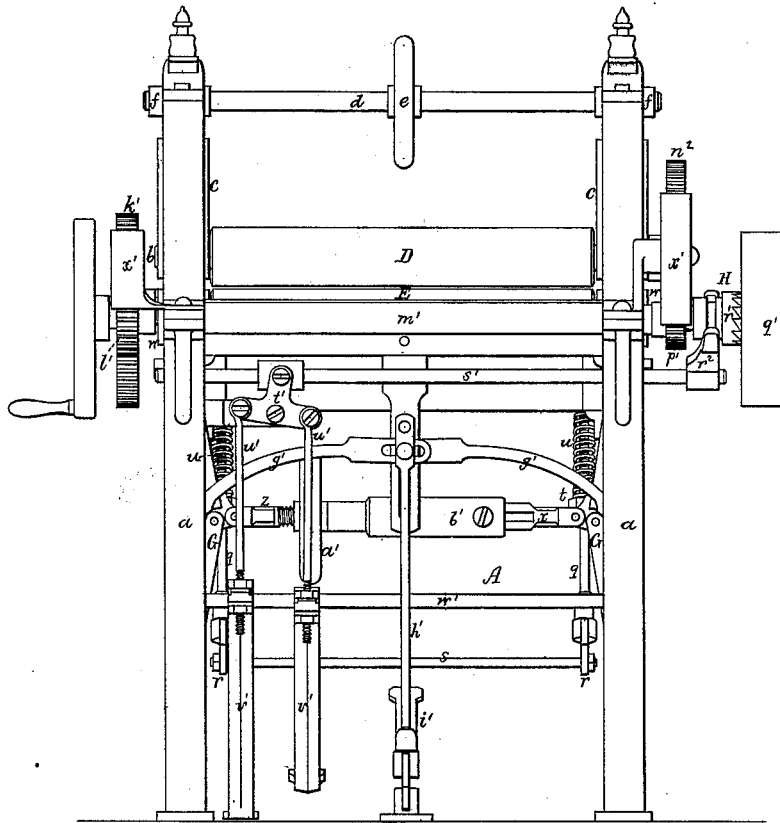

Witnesses

*L. M. Piper*  
*L. M. Miller*

*Inventor*  
*Aaron F. Stowe*

*by his attorney*  
*R. H. Esley*

# UNITED STATES PATENT OFFICE.

AARON F. STOWE, OF WORCESTER, MASSACHUSETTS.

## IMPROVEMENT IN LEATHER-ROLLING MACHINES.

Specification forming part of Letters Patent No. **198,473**, dated December 25, 1877; application filed September 18, 1877.

*To all whom it may concern:*

Be it known that I, AARON F. STOWE, of the city and county of Worcester, of the State of Massachusetts, have invented certain new and useful Improvements in Machinery for Stretching and Rolling or Operating on Leather; and do hereby declare the same to be described in the following specification and represented in the accompanying drawings, of which—

Figure 1 is a rear elevation, Fig. 2 an end view, Fig. 3 a transverse section, and Fig. 4 a longitudinal section, of a machine containing my invention.

Such other figures as may be necessary to a further illustration of my said invention are hereinafter referred to and described.

The frame of the machine is shown at A as composed in part of two vertical standards, *a a*, arranged as represented. Between them is an inclined bed, B, and three rollers, C D E.

Of these rollers, D E are for condensing the leather, one of such rollers being disposed immediately over the other. The upper of them, viz., that marked D, has its journals *b b* in vertically-moving bearing-slides *c c*, properly applied to the two standards, and they are provided with mechanism for effecting vertical movements of the said roller relatively to the roller E. This mechanism, as shown, may be thus described: A horizontal shaft, *d*, provided at its middle with a hand-wheel, *e*, and supported in suitable bearings *f f*, has fixed to it two cams, *g g*, (see Figs. 4 and 5,) the latter being a vertical section taken through the upper half of one of the standards *a*, and in the plane of one of the said cams. Each cam enters a shoe, *h*, supported on the head of a screw, *i*, screwed into the upper part of one of the bearing-slides *c c*. Each bearing-slide is chambered, and has within it a helical spring, *k*, which bears against the top of the chamber, and rests on a shelf, *l*, extending through the slide *c*, and supported within the standard. The spring serves to press upward the slide *c*, and to allow of raising the roller D relatively to the roller E. By revolving the hand-wheel in the proper direction the cams will be caused to depress the slides so as to move the roller D downward. The screws *i* are for effecting

the proper adjustment of the roller D relatively to the roller E.

The roller C, arranged in rear of the rollers D E, and above the inclined shelf or bed B, has its journals supported in movable bearings resting against springs arranged in two adjustable boxes, *m m*, arranged on the bed B, and fixed to it by set-screws *n n* going through slots in the boxes. Fig. 6 is a vertical section of one of the said boxes *m*, with its spring *n'* and the bearing *o* for reception of the journal of the roller. The said roller C is to remove wrinkles from the leather while passing directly over it, and thence between the two rollers D E, the sheet of leather being first led underneath a presser-bar, F, arranged over the lower part of the said bed, and over a groove, *p*, made in and across such bed. The presser-bar is fixed to two rods, *q q*, that extend down through the bed, and are pivoted to the shorter arms of two angular levers, *r r*, pivoted to the two standards, *a a*, and having their longer arms connected by a rod, *s*. A screw-thread is formed on the upper part of each rod, *q*, to receive a nut, *t*, between which and the bed B there is a helical spring, *u*, which encompasses the rod, and serves to draw the presser-bar down toward the bed. By depressing the connecting-rod *s* the pressure-bar will be forced upward off the bed, in order to admit of a skin or piece of leather being introduced between such bar and bed.

The presser-bar serves with the bed to hold a sheet or piece of leather while it may be acted on by the rollers in advance. The bar, by its pressure on the skin or leather, enables the rollers to tightly stretch it. Such bar also aids in removing wrinkles from the leather. The bed may be without the groove to cooperate with the bar in holding the leather and aiding in removing wrinkles from it; but the groove is an addition of practical advantage. Sometimes in the place of the roller C, I use a bar for the leather to pass over; but the roller is preferable on account of it being capable of revolving.

The lower of the two rollers D E, I provide with mechanism for forcing it upward against the leather while it may be between the two rollers. This mechanism may be thus de-

scribed: The journals  $vv$  of the roller E rest in vertically-movable bearings  $ww$ , supported on two sets of toggles, G G, that are stepped in the standards. One of these sets of toggles at its middle is jointed to an arm,  $x$ , extending into a sleeve,  $b'$ , having a slot,  $y$ , in it, as shown. The other set of toggles is pivoted to an arm,  $z$ , which has a screw cut on it, and extends into the sleeve  $b'$ . A hand-wheel,  $a'$ , screwed on the screw, abuts against the inner end of the sleeve  $b'$ . From the arm  $x$  an index or pointer projects through the slot  $y$ , and against a scale,  $c'$ , fixed to the sleeve. Within the sleeve is a helical spring,  $d'$ , which encompasses the arm  $z$ , and bears against the end of the arm  $x$  and a shoulder,  $e'$ , within the sleeve.

On revolving the hand-wheel  $a'$  in the proper direction, the two pitmen or arms  $xz$  will be moved asunder, so as to straighten the toggles, and thereby cause the roller E to be forced upward, the spring within the sleeve rendering the pressure yielding or elastic, in order to allow the lower roller to yield, so as to prevent breakage of any of the mechanism in case of the leather in any part of it being of undue thickness, or presenting an obstacle to the passage of it between the rollers.

By means of the above-described mechanism for actuating the toggles, it will be seen that the pressure exerted by the lower roller on the leather may be varied, the amount of which in tens or other units may be shown by the pointer and the graduated scale, as hereinbefore described.

When the machine is in operation, it may be desirable to temporarily relieve the leather from the pressure upon it without moving the hand-wheel  $a'$ . For this purpose there are pivoted in each of the standards  $aa$  a short shaft,  $e''$ , provided with a cam,  $f'$ , to bear against the next adjacent set of toggles at or near the joint thereof. These cams serve to force back the toggles against the tension of the spring in the sleeve, and thereby to allow the roller E to move downward a little.

For simultaneously revolving the shafts of the said cams, there are extended from them two arms,  $g'g'$ , that are jointed to a rod,  $h'$ , extended upward from a pedal,  $i'$ , all being arranged as represented.

On one journal of the roller E there is fixed a gear,  $k'$ , that engages with a pinion,  $l'$ , fixed on a driving-shaft,  $m'$ , arranged as represented.

Furthermore, to one of the journals of the upper roller D there is fastened a gear,  $n^2$ , which, by means of an intermediate gear,  $o'$ , engages with a pinion,  $p'$ , fixed on the shaft  $m'$ . A band pulley or wheel,  $q'$ , running loosely on the driving-shaft, has, with such, a clutch, H, for engaging it with the shaft. The fork  $r^2$  of the movable part  $r^1$  of the clutch is fixed to a slide-rod,  $s'$ , jointed to a lever,  $t'$ , having three arms. (See Fig. 7, which is a front elevation of the machine.) This lever is jointed to connection-rods  $u' u'$ , projecting upward

from two curved levers or pedals,  $v' v'$ , arranged as shown, and pivoted on a horizontal rod,  $w'$ , extending from one to the other of the standards  $aa$ .

By pressing down the longer arm of one of the said pedals, the band-wheel will be clutched to the driving-shaft, and it will be disengaged or unclutched therefrom by depressing the longer arm of the other pedal. Housings  $x' x'$ , arranged over the gears  $k' l' n^2 o' p'$ , serve to protect them from dust.

From the above it will be seen that on introducing into the machine a side or sheet of leather, it will be drawn underneath the presser-bar, thence over and partially around the roller C, and thence between the rollers D and E, the presser-bar serving to hold the leather so as to enable the rollers D E to stretch it and draw it firmly against the roller C, whereby its folds and wrinkles will be taken out, and it will be condensed or rolled, as may be required.

To the machine thus described I sometimes add, in front of the rollers D E, one or more knives or devices for effecting splitting or cutting of the leather, either horizontally or vertically through it, as occasion may require.

I do not claim a presser-bar in combination and arranged with a roller and a knife, as shown in the United State Patent No. 176,427, as in such case there is neither a bed nor compressing-rollers, as in my machine. Nor do I claim a bar arranged and used with a roller, feed-rolls, and a knife, as shown in the United States Patent No. 13,756, no bed being there shown, and such bar being to operate in a different manner and for a different purpose from the presser-bar herein described, as applied to a bed, and to operate with their rollers, arranged as set forth.

What I claim as of my invention is as follows:

1. In a machine for operating on leather or rolling it, as described, a presser-bar, F, (having mechanism for operating it, substantially as explained,) the bed B, and the condensing-rollers D E, combined and arranged substantially in manner and to operate as set forth.

2. The combination of the presser-bar F (having mechanism for operating it, substantially as explained) with the condensing-rollers D E, and with the bed B, provided with the channel or groove  $p$ , arranged beneath such presser-bar, all being substantially as described.

3. The presser-bar F, (having mechanism for operating it, substantially as explained,) the bed B, the roller C, and the condensing-rollers D E, combined and arranged substantially as set forth.

4. The combination of the presser-bar F, (having mechanism for operating it, as explained,) the roller C, the condensing-rollers D E, and the bed B, provided with the groove  $p$ , arranged beneath the presser-bar F, as specified.

5. The combination of the two pedals  $v' v'$ , connecting-rods  $u' u'$ , lever  $t'$ , and slide-rod  $s'$ , with the clutch-fork  $r^2$ , clutch H, driving-shaft

*m'*, and pulley *q'* of the mechanism for actuating or revolving the condensing-rollers.

6. In combination with the condensing-rollers D E, the two sets of toggles G and their intermediate adjusting mechanism, substantially as described, consisting of the arms *xz*, the hand-wheel *a'*, the sleeve *b'*, and the spring *d'*, arranged, constructed, and applied substantially as set forth.

7. The combination of the mechanism for operating the toggles, consisting of the arms *xz*, the hand-wheel *a'*, the sleeve *b'*, and the spring *d'*, such being provided or not with the pointer and scale, as set forth.

8. In combination with the toggles and their intermediate adjusting mechanism, mechanism for effecting back movements of the toggles, as and for the purpose specified, such mechanism consisting of the cams *f' f'*, shafts *e<sup>2</sup> e<sup>2</sup>*, arms *g' g'*, connecting-rod *h'*, and the pedal *i'*, all arranged and applied essentially as explained.

AARON FRANCIS STOWE.

Witnesses:

R. H. EDDY,  
J. R. SNOW.