

P. S. BUCKMINSTER.  
Clamps for Rock-Drills.

No. 198,485.

Patented Dec. 25, 1877.

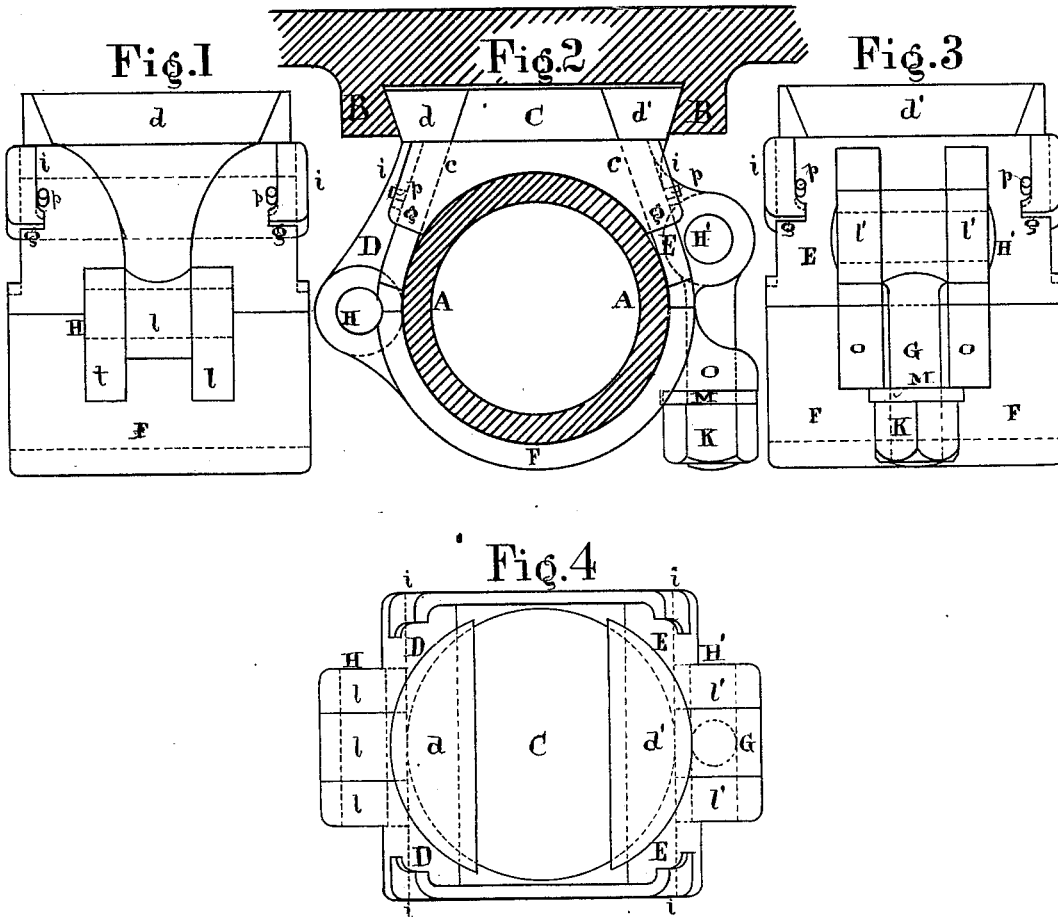

Witnesses  
*Geo Parry*  
*Wm R. Bailey*

Inventor  
*Prescott S. Buckminster*  
*per George Parry*  
*att'y*

# UNITED STATES PATENT OFFICE.

PRESCOTT S. BUCKMINSTER, OF BELLEVILLE, NEVADA.

## IMPROVEMENT IN CLAMPS FOR ROCK-DRILLS.

Specification forming part of Letters Patent No. 198,485, dated December 25, 1877; application filed September 3, 1877.

*To all whom it may concern:*

Be it known that I, PRESCOTT S. BUCKMINSTER, of Belleville, Esmeralda county, Nevada, have invented an Improved Clamp for Rock-Drills, such as are operated with steam or compressed air, of which the following is a specification:

This invention relates to the device which connects the frame which carries the working cylinder of a rock-drill to the support upon which the engine rests. This support is sometimes in the form of a tripod. At other times it takes the shape of a simple column used in tunnels or drifts, and again it is in the form of a carriage, upon which several drills may be supported at one time. In all cases a provision is made for accommodating the same clamp, which is adjusted and clamped upon a cylindrical form, of from four to six inches diameter, forming part of said tripod, column, or carriage.

The construction of the tripod, the drift-column, or the carriage I need not describe, as they do not form part of my invention.

In the accompanying drawing, Figure 1 is an edge view of my clamp, looking from the left. Fig. 2 is a side or front view. Fig. 3 is an edge view, looking from the right; and Fig. 4 is a plan.

Like letters of reference in all the figures of the drawing indicate like parts.

In Fig. 2 of the drawing the principle of my invention is clearly illustrated, the remaining figures simply developing the details of construction.

A, Fig. 2, represents a section of the cylindrical part of an ordinary rock-drill tripod, which my clamp is to enclasp and be adjusted upon; and B indicates a section of the socket part of the frame which carries the working cylinder, in which my clamp is applied. My clamp consists in the combination of the pieces C, D, E, and F, the eyebolt G, and the pins H H'. The piece C has its under side made concave to fit the circumference of the cylinder A, upon which it rests. Its sides *cc* being inclined, as shown in Fig. 2, it forms, as it were, a wedge between the two parts D and E, operating to spread them apart, if pushed upward between them, or, which would be equivalent, if the parts D and E be drawn

down upon the inclined sides the same action takes place. The pieces D and E are held against the inclined surfaces of the piece C, because they play up and down in the grooves *gg*, which are formed by returning the edges of the piece C at *iiii*. The pieces D and E are simply two plates, fashioned at their upper ends to form segments of a disk, *dd'*, with beveled edges, as shown in the several figures, the bevel of the edges corresponding with the bevel of the sides of the socket B, within which the disk is accommodated. The piece D is attached to the half-band F, which circles around the lower half of the cylinder A, by the pin H passing through the lugs *lll*, the two outside lugs being solid with the half-band F, and the middle lug being solid with the piece D. Thus a hinge is formed, upon which the half-band F may swing. The opposite plate E has an eyebolt, G, swinging on the pin H', which pin is passed through the lugs *lll'*, which are solid with the plate E. This bolt G swings in between the lugs *oo*, made solid with the half-band F, the nut K serving to draw the parts together. A washer, M, may intervene between the nut and the lugs *oo*.

To prevent the pieces C and E from falling apart and separating from the remainder of the clamp, when the clamp is open and detached from the drill, I have provided pins or stops *pp* upon the pieces D and E, which, striking against projections on the returned edges of the piece C, limit the movement of the pieces D and E within the retaining-grooves *gg*; otherwise nothing would prevent these pieces from slipping through and becoming separated, which would be a serious objection, as it would render the pieces liable to be lost when so separated.

The action of the device is simple, and as follows: The beveled-edged disk formed by the upper part of the clamp is inserted within the socket B, as shown in Fig. 2, and the clamp adjusted upon the tripod, drift-column, or carriage, as the case may be. The clamp is then closed and swung in between the lugs *oo*, and the nut is screwed up tightly, which draws down the pieces D and E, spreading them apart, and binding them within the socket B. At the same time the half-band F is drawn up, and also binds tightly upon the cylinder

A. Thus a complete and rigid clamping of the parts together is effected.

When the nut is slackened and the clamp loosened, the drill may be swung around in both a vertical and horizontal plane, and clamped at any point desired.

What I claim as my invention, and desire to secure by Letters Patent, is as follows:

The clamp consisting of the pieces C, D, E, and F, and the adjusting-bolt G and pins H H', combined together and operating in the manner and for the purpose herein described.

P. S. BUCKMINSTER.

Witnesses:

J. W. HOGAN,  
RUFUS BATES.