

J. PAGIN.
Harvester-Rake.

No. 198,520.

Patented Dec. 25, 1877.

Fig. 1.

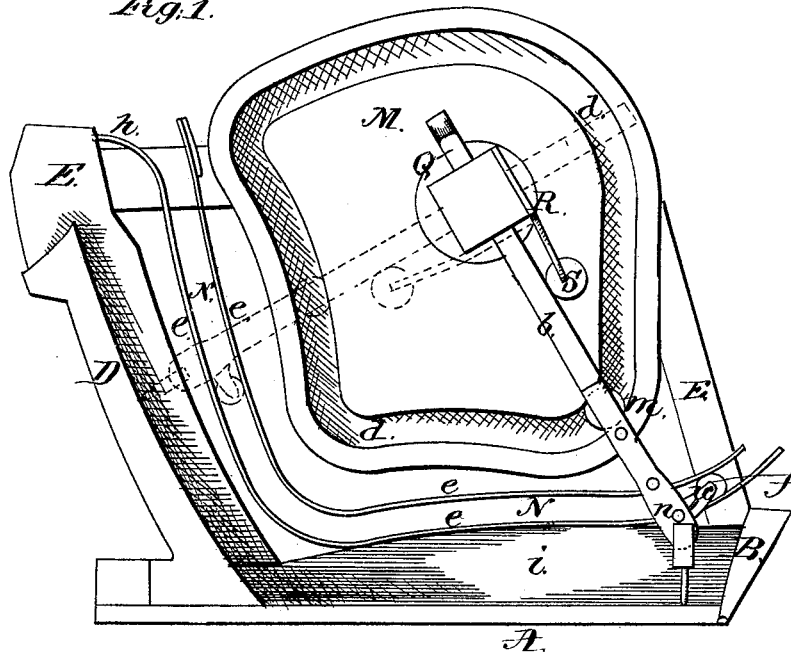
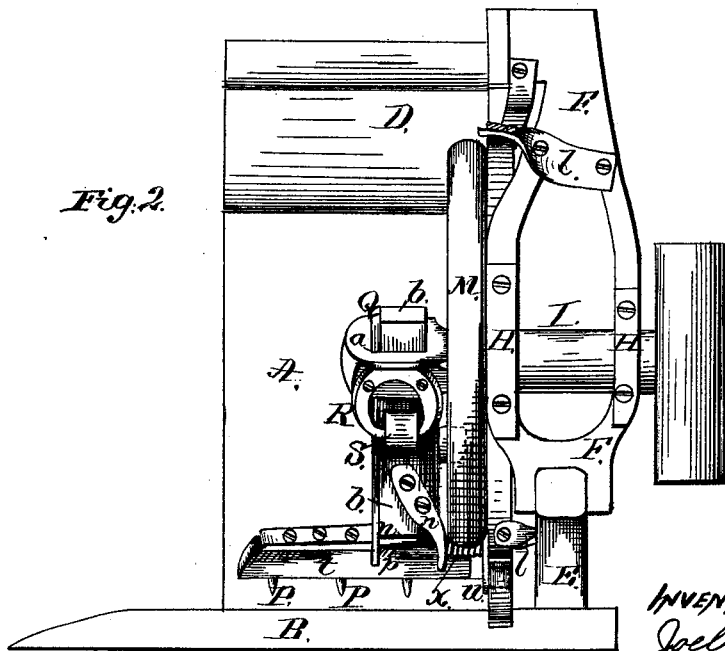

Fig. 2.



WITNESSES;

H. Maister Fowler
Chas. C. Hill

INVENTOR;
Joel Pagin
By his atty.
Cox & Cox

UNITED STATES PATENT OFFICE.

JOEL PAGIN, OF WASHINGTON PRAIRIE, IOWA.

IMPROVEMENT IN HARVESTER-RAKES.

Specification forming part of Letters Patent No. **198,520**, dated December 25, 1877; application filed November 26, 1877.

To all whom it may concern:

Be it known that I, JOEL PAGIN, of Washington Prairie, in the county of Winneshiek and State of Iowa, have invented a new and useful Improvement in Self Grain-Rakes, of which the following is a specification, reference being had to the accompanying drawings.

The invention relates to an improvement in self grain-rakes; and consists in the devices hereinafter fully described.

The object of the invention is to furnish a suitable means for removing or conveying the grain from a platform, on which it falls as it is cut, to a grain-binder, where it may be bound in sheaves.

In the accompanying drawings, Figure 1 is a plan view of a device embodying the elements of the invention. Fig. 2 is a top view of same.

A represents a suitably-constructed platform, provided on one end with the divider B, to which the grain-wheel (not shown) is attached. The platform A is furnished on its other end with the slightly-concave inclined siding D, which extends upward a proper distance to deliver the grain on the platform of a grain-binder. (Not shown.) Upon either end of the platform A is secured the standard E, the upper ends of which support the frame F, provided on opposite sides with the journal-bearings H, containing the horizontal shaft I, the front end whereof is enlarged, as shown, and is provided with a through-slot, *a*, in which the rake-handle *b* has a free sliding movement, and will be mentioned hereinafter. Upon the vertical side of the frame F, and facing forward, is centrally secured, around the shaft I, the cam M, which is supplied on its face, and adjacent the outer edge of same, with the groove *d*, as shown. Below the cam M, and along the side of same, opposite the divider B, passes the guideway N, consisting of the bars *e*, which resemble very nearly the contour of the cam and incline D, and are properly separated to receive the friction-wheel *f*, hereinafter described. The tramway is open at both ends, and at the upper portion of its inclined end the lower bar *e* curves outward, as shown at *h*, and is secured to the frame F, the curved part *h* being above the upper edge of the incline D. The bars *e* may be secured in place

in any convenient manner; at present, however, the lower bar rests upon the support *i*, and the upper bar is retained by hangers *l*, secured to the standard E and upper portion of the frame F.

The rake-handle *b* has its upper end placed in the slot *a* of the shaft I, and is furnished on its side facing the cam, and at a suitable distance from its upper end, with the guide-wheel *m*, which travels in the groove *d*, adjusting itself to the irregularities of the same, and thereby either drawing or retracting the handle in the slot *a*. The lower end of the handle *b* is provided with bearings *n*, in which the bar *p* is mounted and has a rotary motion. That portion of the bar *p* which projects forward beyond the bearings *n* is secured to the upper surface of the rake *t*, and that portion of same which projects rearward is supplied on its extremity with the arm *u*, which extends outward a suitable distance, and is furnished with a short arm, extending rearward, and serving as an axle for the anti-friction or guide wheel *f*, which moves in the guideway N, and thereby controls the sweep of the rake *t*. Between the rear bearing *n* and the arm *u* the coiled spring *x* is placed on the bar *p*, and has one of its ends attached to the said bearing *n*, the other end being secured to the lower edge of the said arm *u*, thus giving the said arm a downward tension, at the same time causing the bar *p* and rake *t* to have a rotary movement toward the incline D. The rake *t* is provided with suitable teeth P, for collecting the grain. Within the slot *a*, and in front of the handle *b*, is secured the dog Q, the lower end of which impinges the said handle, and retains it in proper relation to the cam M. Upon the side of the enlarged or front end of its shaft I, nearer the divider B, is supplied the hanger R, which extends downward and carries the anti-friction wheel S, which rests against the face of the handle *b*, and thereby insures a free and easy movement of the same in the slot *a*.

It is evident that when the shaft I is rotated the handle *b* and rake *t* are moved in the same direction along the platform A, up the incline D, and over the cam M, making a complete revolution.

It is also evident that while this movement

is taking place the action of the anti-friction and guide wheels *f* and *m* in the guideway N and groove *d* either draws or retracts the handle *b* in the slot *a*, thereby conforming the motion of the rake to the surface over which it passes.

The grain, as it falls upon the platform A, is carried up the incline D, and is thrown over the top of same upon a grain-binder, (not shown,) which binds the said grain in sheaves.

I claim—

1. In a self grain-rake, the vertical cam M, provided with the groove *d*, in combination with the overhung rake *t* and guideway N, all being arranged substantially as shown and described.

2. The vertical handle *b*, placed in slot *a* of the shaft I, and provided with the wheel *m*,

which travels in the groove *d*, in combination with the bar *p*, overhung rake *t*, spring *x*, arm *u*, wheel *f*, and guideway N, substantially as specified.

3. The platform A, incline D, handle *b*, and overhung rake *t*, provided with spring *x*, and wheels *f m*, in combination with the guideway N and cam M, furnished with the groove *d*, substantially as set forth.

In testimony that I claim the foregoing improvement in self grain-rakes, as above described, I have hereunto set my hand this 12th day of November, 1877.

JOEL PAGIN.

Witnesses:

J. B. B. BAKER,

A. E. GOODYKOONTZ.