

J. DAVIES.

Reciprocating Engine.

No. 198,535.

Patented Dec. 25, 1877.

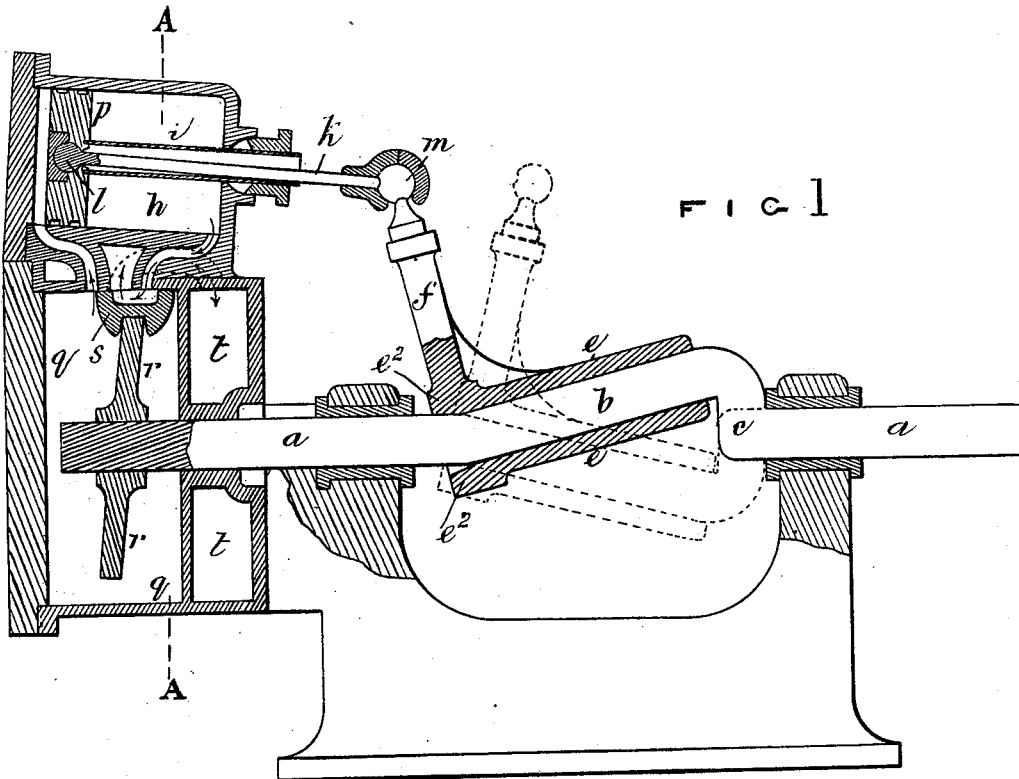

FIG 1

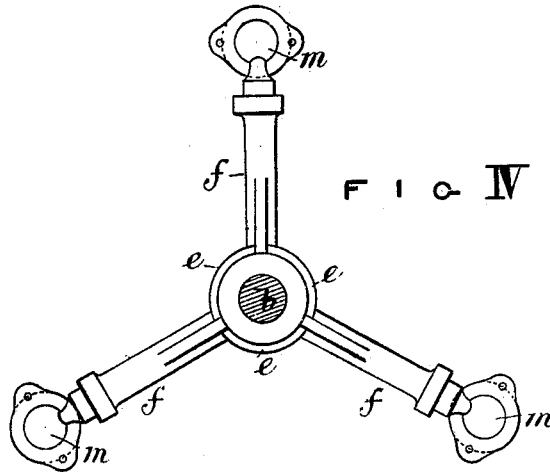

FIG IV

Witnesses,  
*George Shaw*  
*Richard Bennett.*

Inventor  
*James Davies.*

J. DAVIES.

Reciprocating Engine.

No. 198,535.

Patented Dec. 25, 1877.

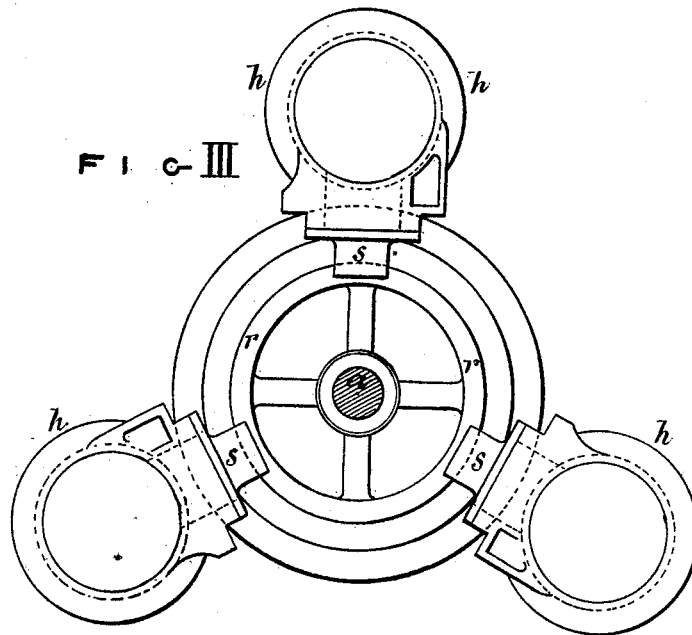
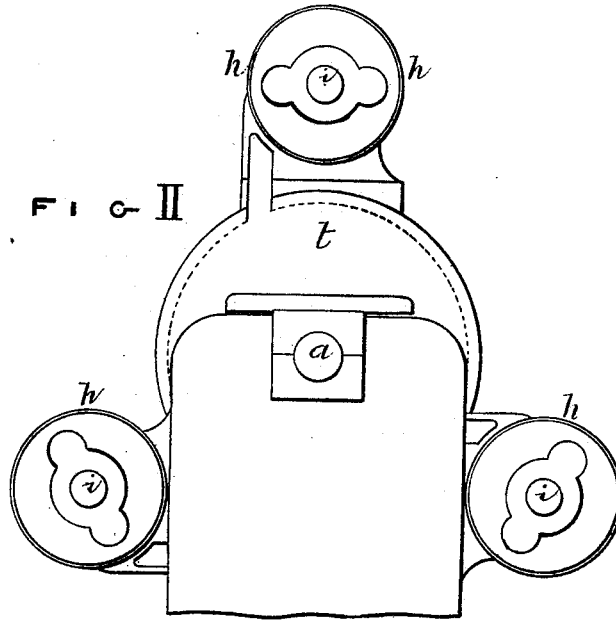

Witnesses,  
*George Shaw*  
*Richard Bennett.*

Inventor  
*James Davies.*

# UNITED STATES PATENT OFFICE.

JAMES DAVIES, OF WEDNESBURY, ENGLAND.

## IMPROVEMENT IN RECIPROCATING-ENGINES.

Specification forming part of Letters Patent No. **198,535**, dated December 25, 1877; application filed October 4, 1877; patented in England, August 18, 1876, for fourteen years.

*To all whom it may concern:*

Be it known that I, JAMES DAVIES, of Wednesbury, in the county of Stafford, England, manufacturer, have invented new and useful Improvements in Steam-Engines, which improvements are fully set forth in the following specification, reference being had to the accompanying drawings.

My invention consists of the construction and arrangement of the parts of steam-engines hereinafter described, whereby great compactness is obtained and great economy in the production of motive power from steam is effected.

According to my said invention rotary motion is communicated to the main shaft of the steam-engine by cranking or fastening part of said shaft of such a figure that on the rotation of the shaft the said cranked part describes a cone, and urging forward the said cranked part of the shaft by means of arms actuated by steam-cylinders, the said arms being constructed and combined with said cranked part, and acting substantially as hereinafter illustrated and described.

To carry this my said invention into effect, I arrange three double-acting steam-cylinders symmetrically about the shaft. The pistons of these steam-cylinders are connected with the arms hereinafter described, and their valves are so arranged that they in succession act upon the said arms, and produce the conical motion described in the rod or tubular casing, and the consequent rotary motion in the crank and shaft. The pistons of the steam-cylinders have hollow piston-rods working in stuffing-boxes at the cover ends of the cylinders. The said hollow piston-rods are open at one end, and in the said hollow rods are solid connecting-rods, connected at one end by a ball-and-cup joint to the piston, and at the other end by a ball-and-cup joint to the arms described. This arrangement allows of the required oscillating motion in the said connecting-rods. The valves are worked by an oblique wheel or plate on one end of the crank-shaft, which oblique wheel acts in turn upon the several valves of the steam-cylinders. Although I prefer to use not less than three equidistant steam-cylinders, yet one, two, or a greater number than three may be employed. When

one cylinder is employed, a fly-wheel is desirable to equalize the motion; but when two or more are employed no fly-wheel is necessary.

I will now describe, with reference to the accompanying drawings, the manner in which my invention may be performed.

Figure 1 represents, in vertical longitudinal section, a steam-engine constructed according to my invention. Fig. 2 is an end elevation of the same, and Fig. 3 is a vertical transverse section taken through the line A A of Fig. 1. Fig. 4 is an elevation of a portion of the same, as hereinafter described.

The same letters of reference indicate the same parts in the several figures of the drawings.

*a* is the shaft of the steam-engine, to which a rotary motion is to be given. *b c* is the cranked part of the shaft, which, on the rotation of the said shaft, describes a cone. On the part *b* of the shaft a tubular casing, *e*, is situated. *f f f* are three arms situated at that end of the tubular casing *e* which, on the rotation of the shaft *a*, is near the apex of the cone described by the parts *b c*. Fig. 4 represents the hollow or tubular casing *e* and the three equidistant arms *f f f* attached to or formed in one piece with it. *h h h* are the steam-cylinders, arranged symmetrically about the shaft *a*. The three arms *f f f* are connected respectively to the pistons of the three cylinders *h h h*, in the manner hereinafter described. The axes of the steam-cylinders *h h h* are not parallel, but are inclined in the manner illustrated in Fig. 1.

By the inclination of the axes of the cylinders the pressure of the part *e* on the shaft is diminished, and the friction consequently reduced. The hollow piston-rods *i i i* of the pistons working in the steam-cylinders *h h h* are hollow and open at their outer ends. (See Fig. 1.) In these hollow piston-rods *i* solid connecting-rods *k* work, one end of each of the rods being connected by a ball-and-cup joint to the piston *p* at *l*, and the other end of the connecting-rod being connected by means of a ball-and-cup joint at *m* to the arm *f*. By an examination of Fig. 1 it will be seen that, when the shaft *a* is turned through a small angle out of the position in which it is represented, the pressure of steam on the under

side of the piston *p*, causing the piston to move to the cover end of the cylinder *h*, urges forward the ball at *m* on the end of the arm *f*, and tends, through the tubular casing *e*, to cause the cranked parts *b c* of the shaft to perform a semi-rotation. The latter position of the arm and crank is indicated in Fig. 1 in dotted lines. Steam being now made to press on the upper side of the piston *p*, the arm *f* is drawn back to its original position, the crank *b c* describing a second semi-rotation and returning to its original position. As the three arms *f f f* (see Fig. 4) and the three cylinders *h h h* (see Figs. 3) are arranged at equidistant points around the shaft *a*, the action of the engine is perfectly uniform in every position of the crank *b c*.

The valves of the steam-cylinders are worked by the arrangement of parts represented in Figs. 1 and 3. The end of the shaft *a* works in the steam chest or chamber *q*, and carries an oblique wheel or disk, *r*. *s* is the slide-valve of the cylinder *h*, in a slot in the back of which the periphery of the oblique wheel or disk *r* engages. *t* is the exhaust-chamber.

It will be seen by an examination of Fig. 1 that, as the shaft *a* rotates, the oblique disk or wheel *r* will, at each rotation of the shaft, give the required motion to the slide-valves to connect the upper and lower ends of the cylinder *h* at the required times with the steam-chest *q* and exhaust-chamber *t*, respectively. It will also be understood by an examination of Fig. 1 that the inclined wheel or disk *r* acts in

succession on the several slide-valves *s* of the cylinders *h h h*. The inclined wheel or disk *r* may be so connected with the shaft *a* that it may be inclined in an opposite direction to that represented in the drawing. By changing the inclination of the said wheel or disk the direction in which the shaft *a* rotates is changed.

It will be understood that the explanation I have given with respect to one of the cylinders *h* and one of the arms *f* is applicable to each of the three cylinders and the arm connected therewith.

Having now described the nature of my invention, and the manner in which the same is to be performed, I wish it to be understood that I claim—

A steam-engine in which a crank-shaft, fashioned to describe a cone on the rotation thereof, is combined with three equidistant double-acting inclined steam-cylinders, arranged symmetrically about said shaft, and surrounding part of said shaft, a sleeve with projecting arms, the ends of which are connected with the steam-pistons in said cylinders, together with inclined disk, to operate successively the slide-valves of said cylinder, all substantially as herein shown and described.

JAMES DAVIES. [L. S.]

Witnesses:

GEORGE SHAW,

RICHARD SKERRETT,

*Of 37 Temple street, Birmingham.*