

J. W. HARRISON.
Coal-Mining Machines.

No. 198,610.

Patented Dec. 25, 1877.

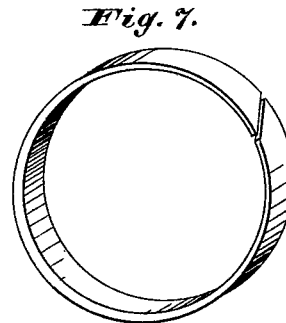
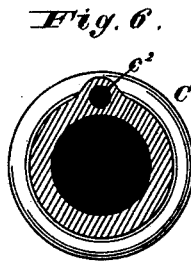
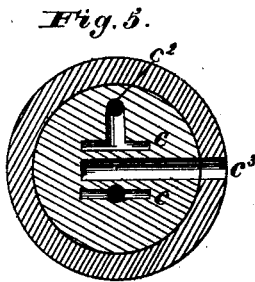
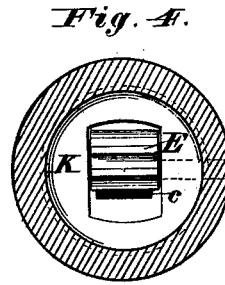
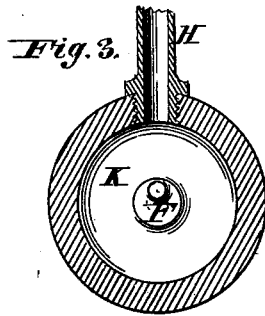
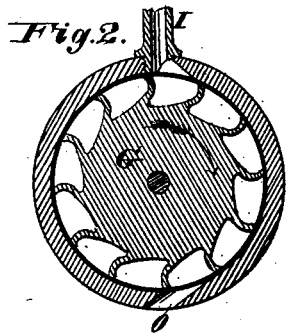
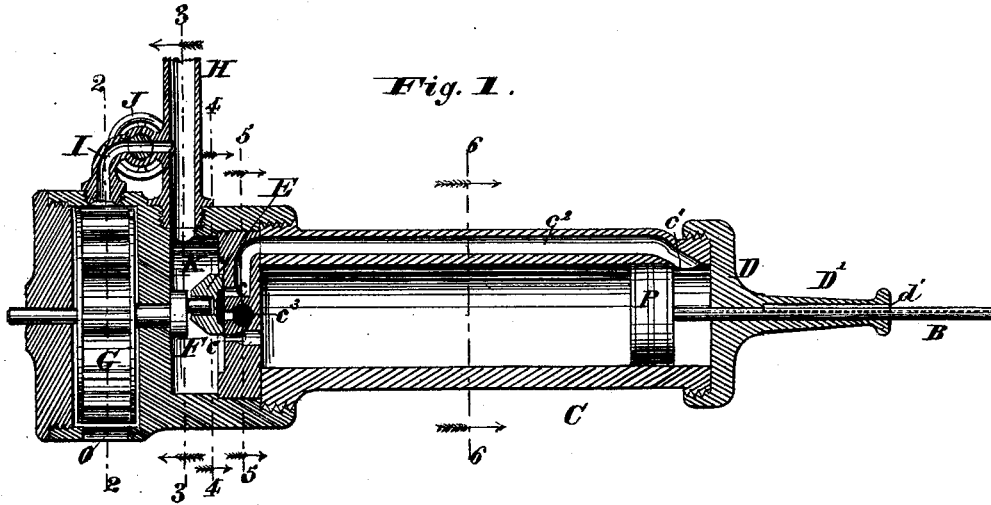

WITNESSES
Chas J. Gooch
A. H. Galt

INVENTOR
Jonathan W. Harrison
 By *Smith & Co.* Attorneys

J. W. HARRISON.
Coal-Mining Machines.

No. 198,610.

Patented Dec. 25, 1877.

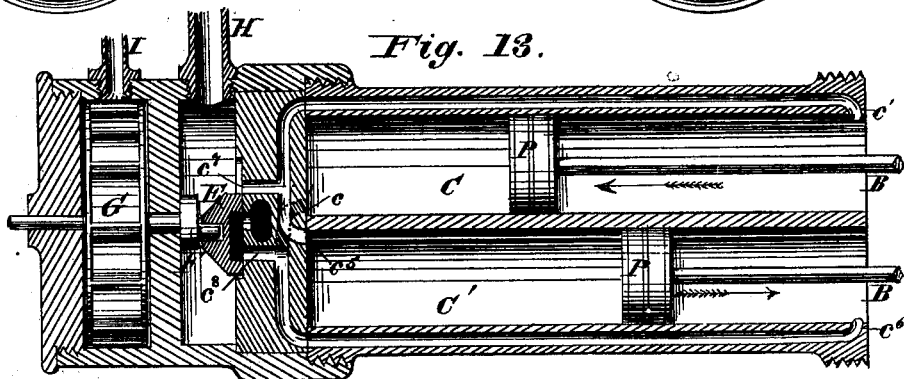
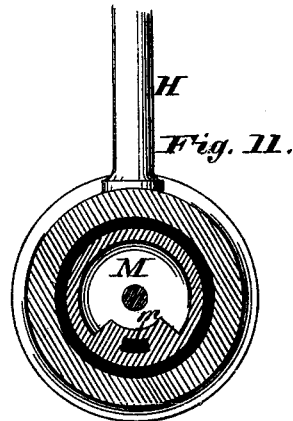
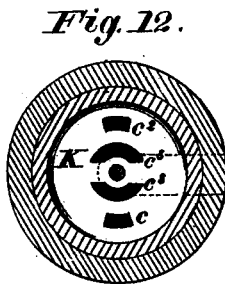
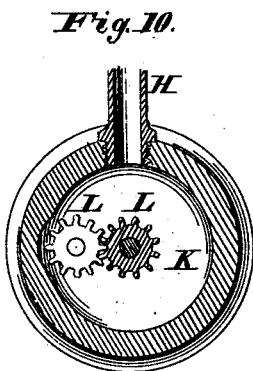
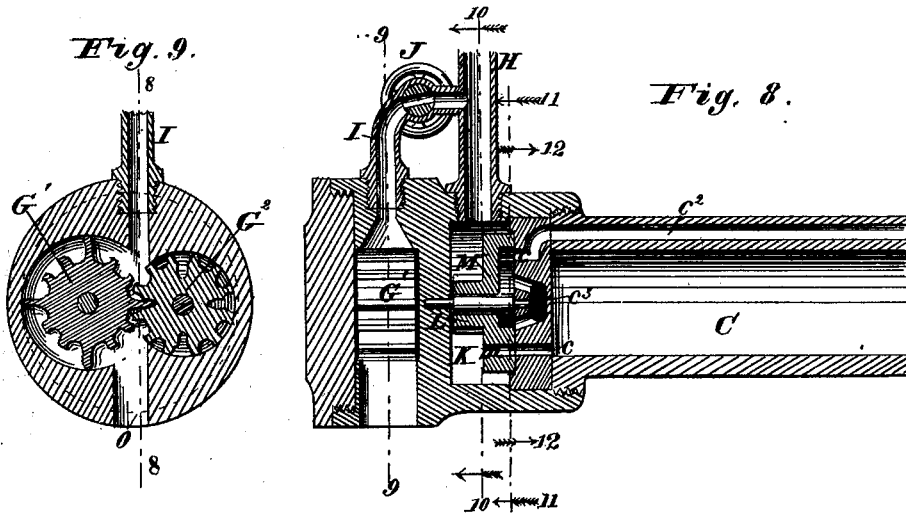

WITNESSES

Chas J. Gooch
A. Galt

INVENTOR

Jonathan W. Harrison
By *Knight Bros* Attorneys.

UNITED STATES PATENT OFFICE.

JONATHAN W. HARRISON, OF ADRIAN, MICHIGAN, ASSIGNOR OF ONE-HALF HIS RIGHT TO JONATHAN E. INGERSOL, OF SAME PLACE.

IMPROVEMENT IN COAL-MINING MACHINES.

Specification forming part of Letters Patent No. **198,610**, dated December 25, 1877; application filed May 29, 1877.

To all whom it may concern:

Be it known that I, JONATHAN W. HARRISON, of Adrian, in the county of Lenawee and State of Michigan, have invented a new and Improved Machine for Mining Coal, of which the following is a specification:

This invention relates to a machine or apparatus for undercutting and "shearing in," or producing any other cuts or excavations, such as are required in mining coal preparatory to wedging out or displacing the mass of material.

The machine is constructed with a reciprocating drill or pick of peculiar construction, operated by a piston worked by compressed air or steam under control of either a rotary or reciprocating valve, deriving its motion from bucket-wheels, which are actuated either by a current or by direct pressure of air or steam conducted from the supply-pipe from which the drill-piston is worked, the amount of compressed air supplied to the valve being regulated by a cock, so as to vary the speed of the valve, and consequently the length and rapidity of stroke of the drill-piston, while the pressure on the latter is unchanged.

The peculiarity in the reciprocating drill or pick consists in forming it with a double flaring point and a concave face, whereby it is caused to cut properly in line, and is preserved from deflection by contact with the coal, the piston-rod which carries the drill or pick being guided so as to keep the working-face in one plane.

In the accompanying drawings, Figure 1 is a longitudinal section of the working parts, omitting the drill-head. Fig. 1^a is an elevation, on a larger scale, of the reciprocating drill or pick and a portion of the rod to which it is attached. Fig. 2 is a transverse section of the valve-wheel on the line 2 2, Fig. 1. Fig. 3 is a transverse section on the line 3 3, Fig. 1, showing the eccentric or crank which operates the valve. Fig. 4 is a transverse section on the line 4 4, Fig. 1, showing the reciprocating valve in elevation. Fig. 5 is a transverse section through the air or steam ports on the line 5 5, Fig. 1. Fig. 6 is a transverse section

through the cylinder on the line 6 6, Fig. 1. Fig. 7 is a perspective view, on a larger scale, of an eccentric-ring used for packing the piston. Fig. 8 is a longitudinal section of the rear part of the cylinder and of the valve-gear, illustrating a modification in the mode of working the valve. Fig. 9 is a transverse section through the valve-wheels on the line 9 9, Fig. 8. Fig. 10 is a transverse section on the line 10 10, Fig. 8. Fig. 11 is a transverse section on the line 11 11, Fig. 8. Fig. 12 is a transverse section in the same plane as Fig. 11. The arrows applied to the various cutting-lines indicate the direction in which each section is viewed. Fig. 13 is a longitudinal section of the rear portion of the apparatus, illustrating the mode of embodying the invention in a double-acting machine.

A represents a drill or pick-head of peculiar construction, attached, by screwing or other means, to a piston-rod, B, by which it is operated. The drill is constructed with a flaring or divergent double point, *a a*, connected by a concave cutting face or edge, *a'*. This construction of the cutting-face and point preserves the drill from liability to be deflected from the face of the cut which it is forming, and imparts to it a tendency to hug or penetrate toward the face, which effectually counteracts the natural deflecting tendency of the face of the material against which it is working, in case of it being employed in enlarging an under-cut or other channel in the coal.

In order to preserve the cutting-face of the drill in vertical or other required plane, to cause it to work as required, the operating-rod B is guided within the head D of the cylinder C. For this purpose the rod is formed with a longitudinal groove, *b*, receiving a tongue or feather, *d'*, within the guiding-nozzle or projecting end D' of the cylinder-head D.

The guiding of the drill-rod* B may, if preferred, be effected by other means than those represented. For example, a set-screw may take the place of the spline or feather *d'*, or the rod may be made of square or other non-circular shape, as illustrated in Fig. 13,

and fitted in a corresponding opening in the head.

The drill-head A may be secured from unscrewing or turning on the rod B by means of a pin or a spring-catch.

The rod B is of any required length to cause it to reach within the mass of coal, and to form an under-cut or other channel of the required depth. The cylinder C is of any necessary length to adapt the mechanism to impart the length of stroke required to the drill or pick. $c c'$ are the ports for the admission and discharge of compressed air or steam at the respective ends of the cylinder C, c^2 being a longitudinal duct, which connects the port c' with the valve-seat. c^3 is the exhaust-port. E represents a reciprocating valve, adapted by its shape to admit steam to each of the ports $c c'$ alternately, and placing the other in communication with the exhaust c^3 , in customary manner. The valve E is operated by a crank or eccentric, F, which, in the simple form of the invention shown in Fig. 1, derives a continuous rotary motion from a bucket-wheel, G, operated by a current of compressed air or steam, as the case may be, received through the branch pipe I from the compressed air or steam supply pipe H, under the control of a cock, J, and discharged through an exhaust-passage, O. The pipe H is in constant communication with the valve-chest K, so as to maintain a constant pressure within the valve-chest, and apply the same to the respective ends of the piston P alternately whenever the ordinary throttle-valve is opened.

By means of the cock J the amount of compressed air or steam admitted to the valve-wheel G is regulated without changing the pressure applied to the piston in the cylinder. The effect of this is to impart a more or less rapid movement to the valve relatively to the piston, and hence to vary the length and rapidity of the stroke of the piston without changing its force or rapidity of motion. For packing the piston P, I prefer to employ the eccentric-cut ring illustrated in Fig. 7, by reference to which figure it will be seen that the ring is made much thinner on one side than the other, and is cut at its thinnest point; or, in other words, a disk of metal from which the ring is to be formed is bored eccentrically, and the ring then cut at the thinnest point. This causes the severed ends to spring outward, and accurately fit the interior of the cylinder. Two such rings are employed on the piston in customary manner, so as to lap or break the joints.

In the modifications of the invention shown in Figs. 8 to 11, inclusive, the valve is worked by the positive pressure of steam, instead of by a current. For this purpose a pair of wheels, $G^1 G^2$, are constructed and coupled together in a manner common in rotary engines. These may act upon a reciprocating valve, E, through the medium of an eccentric

or crank, F, in the manner described, or they may operate through gearing L L, Fig. 10, on a continuously-rotating valve, M, Fig. 11, constructed with a steam-port, m , of limited length, and an extended exhaust-port occupying the chief part of its circumference. Fig. 12 shows a suitable valve-seat for this rotary valve, $c c^2$ being the steam-ports leading to the respective ends of the cylinder, and c^3 the exhaust-port.

Two cylinders, C C', may be cast in one piece, as illustrated in Fig. 13, the valve E being operated in the manner before described with reference to Figs. 1 to 6, inclusive. The steam-port c' at the forward end of the cylinder C and the port c^2 at the rear end of the cylinder C' connect with one and the same port, c' , in the valve-seat. In like manner the steam-port c^2 at the forward end of the cylinder C' and the port c of the cylinder C communicate with one port, c^2 , in the valve-seat, the port c of the cylinder C being represented in dotted lines.

Operation: The apparatus may be carried by one or more workmen, or may be supported in any other preferred manner, the connection of compressed air or steam with the pipe H being made by means of a flexible hose. The pick or drill being brought up to its work, the cock J is opened to a sufficient extent to impart the desired length and rapidity of stroke, and, the apparatus being moved as required from side to side, the undercutting is quickly effected, and the "shearing-in" or any other cutting is done by the same apparatus, in readiness for displacing the mass of coal or other material.

If a short and quick stroke is required, the piston may be previously set at any desired position within the cylinder, and it will be reciprocated back and forth from this point by the action of the compressed air or steam under control of the valve-wheel.

As the valve-gear is independent of the operating-piston, the motion of the valve will continue without interruption whether the piston moves or not, so that in case the piston becomes locked no damage results; but the instant the piston is brought again into position to operate, or is released, its work will be resumed.

I am aware that rotary drills are commonly made with concave faces, and therefore do not claim such a drill.

Having thus described my invention, the following is what I claim as new and desire to secure by Letters Patent:

1. The combination of the concave-faced or double-pointed pick-head A and the rod B, having a longitudinal reciprocating motion, and guided by a tongue or groove, so as to retain the pick-points in a vertical plane.

2. The combination of the drill or pick A a', the piston-rod B, the cylinder C, and the cylinder-head D, constructed with a project-

ing nose, D', provided with means for guiding the drill-rod, in the manner explained.

3. In combination with a reciprocating drill or pick, A, and a piston, P, for operating the same, and a valve-motor, the pipe H, having direct communication with said piston, and a branch pipe, I, connecting the pipe H

with the motor, as and for the purpose set forth.

JONATHAN W. HARRISON.

Witnesses:

OCTAVIUS KNIGHT,
LE BLOND BURDETT.