

S. W. JAMISON.
Leather-Crimping Machine.

No. 198,622.

Patented Dec. 25, 1877.

Fig. 1.

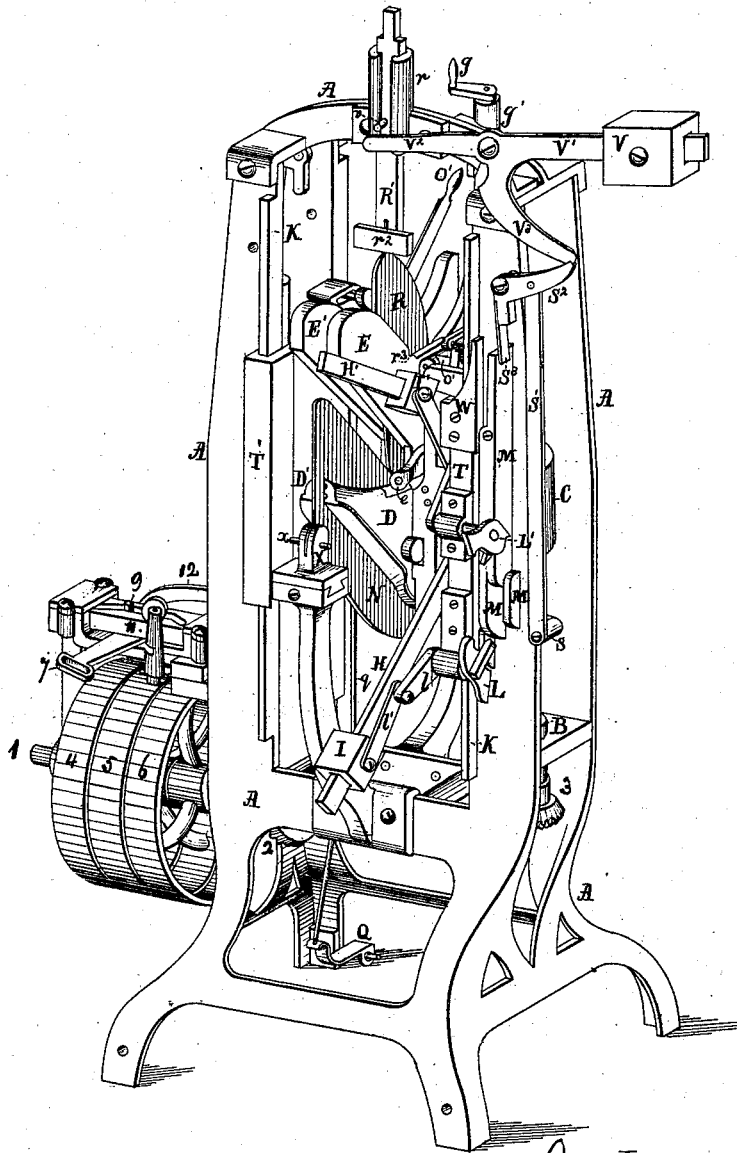

Witnesses:

E. A. Dick
Bertram Early

Inventor:

Samuel W. Jamison
by *A. Pollak*
his attorney.

S. W. JAMISON.
Leather-Crimping Machine.

No. 198,622.

Patented Dec. 25, 1877.

Fig. 3.

Fig. 4.

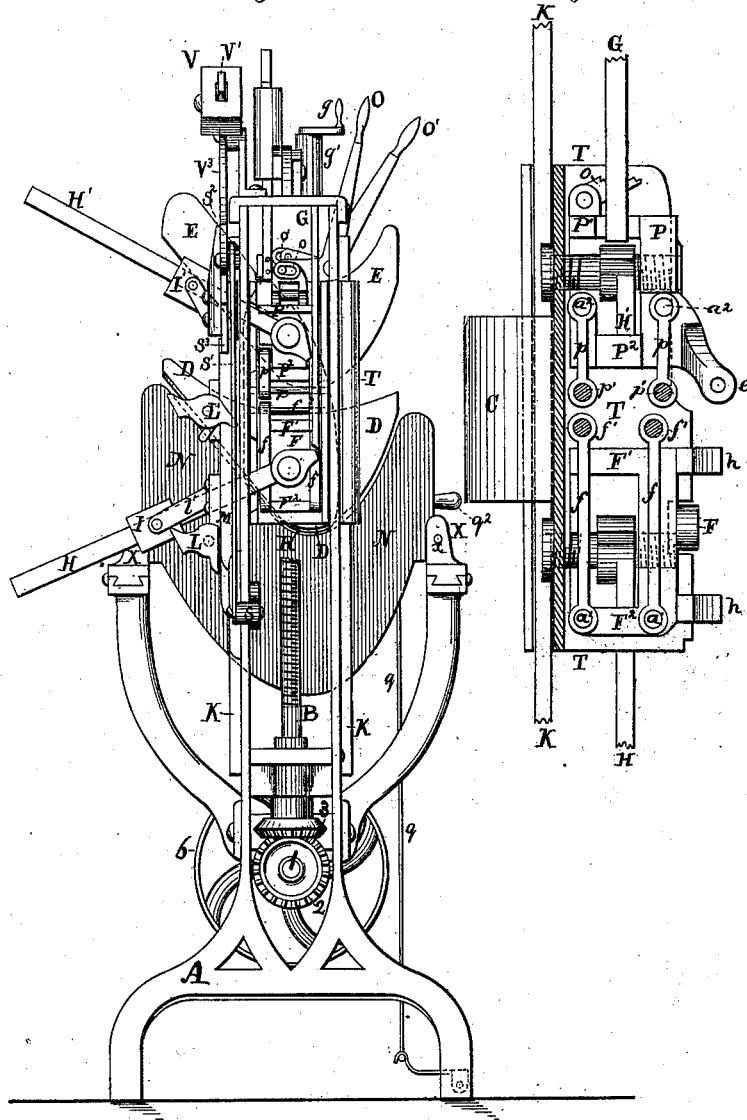

Witnesses:

E. Adick
Bertram Zorley

Inventor:

Samuel W. Jamison
 by *A. Pollok*
 his attorney

S. W. JAMISON.
Leather-Crimping Machine.

No. 198,622.

Patented Dec. 25, 1877.

Fig. 2.

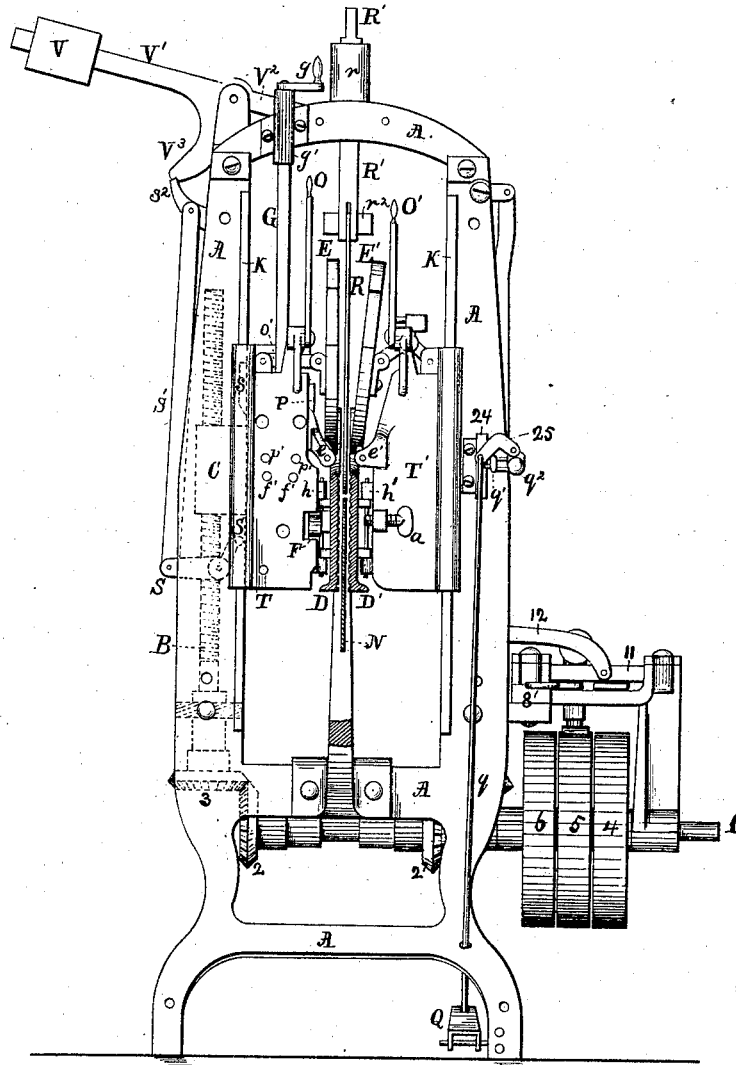

Witnesses:

W. A. Dick
Bertram Jewell

Inventor:

Samuel W. Jamison
 by *A. Pollok*
 his attorney

S. W. JAMISON.
Leather-Crimping Machine.

No. 198,622.

Patented Dec. 25, 1877.

Fig. 5.

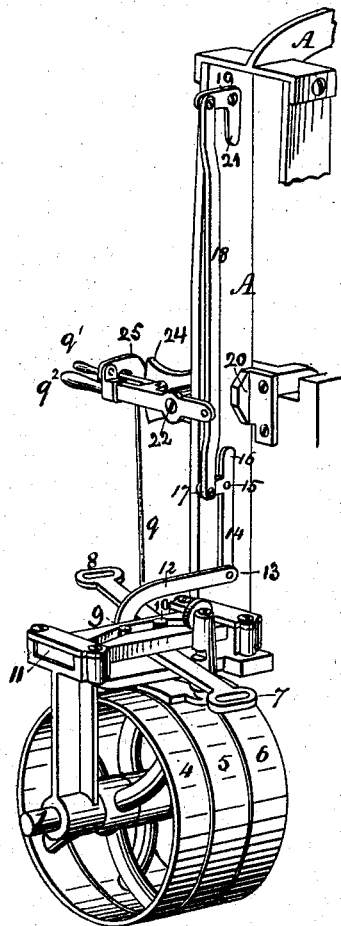

Witnesses:

C. A. Dick
Burham

Inventor:

Samuel W. Jamison
by *A. Pollock*
his attorney

UNITED STATES PATENT OFFICE.

SAMUEL W. JAMISON, OF NEWARK, NEW JERSEY, ASSIGNOR TO S. W. JAMISON BOOT AND SHOE CRIMPING MACHINE COMPANY.

IMPROVEMENT IN LEATHER-CRIMPING MACHINES.

Specification forming part of Letters Patent No. **198,622**, dated December 25, 1877; application filed July 5, 1877.

To all whom it may concern:

Be it known that I, SAMUEL W. JAMISON, of Brooklyn, Kings county, New York, have invented certain new and useful Improvements in Machines for Crimping Leather for Boots and Shoes and other articles, of which the following is a specification:

My improvements, subject-matter of this patent, relate, first, to the manner in which the moving parts of the machine are arranged and operated in relation to the frame or ways, which are not movable, as in similar machinery which I have heretofore constructed, but are rigid; second, to the manner in which the crimping-jaws are operated so as to preserve their parallelism; third, to the means whereby said jaws are self-adjusting; fourth, to the manner in which the jaws are supported and hung in their respective trucks, so that they are independent of each other, and free to adjust themselves; fifth, to the manner of hanging the jaws by means of links, whereby friction is avoided; sixth, to the means, hereinafter described, by which the jaws are moved up and down the ways and stopped automatically at the respective ends of their course; seventh, to a novel combination, with the boot-crimping machinery, of belt-shifting devices operated by treadle, whereby the operator may at will start the machine with his foot, leaving his hands free to hold the article to be or being crimped in its proper place; eighth, to the combination, with the crimping mechanism, of special mechanism for preventing wrinkles being formed on the leather, under the arrangement hereinafter shown and described, whereby the wrinkle-preventer automatically moves out of the way, to allow of the ready and convenient removal of crimped and smoothed leather from the machine, and of the insertion therein of another piece of leather to be crimped; ninth, to the peculiar shape of the crimping-jaws, whereby action on the heel portion of the leather is continued after the toe or top part shall have passed through the crimper; tenth, to the manner in which the tree or form is held and supported, allowing of its ready removal and insertion in lieu thereof of differently-shaped trees or forms, substantially as hereinafter shown and set forth.

To enable others to make and use my said invention, I shall now proceed to describe, by reference to the drawings, the manner in which the same is or may be carried into effect.

In said drawings, Figure 1 is a perspective view of a machine made in accordance with my said invention. Fig. 2 is a front elevation with portions cut away. Fig. 3 is a side view, partly in elevation and partly in section; Fig. 4, a detail view on an enlarged scale, partly in elevation and partly in section; and Fig. 5, a perspective view of the shifting device.

Each letter represents the same part in all the figures.

The working parts of the machine are supported by a pedestal and stationary frame, A. To this frame are secured the upright ways K, upon which slide the two trucks T and T', moved up and down by means of upright screw-shafts B, which are located one on each side of the machine.

The shafts pass through screw-threaded boxes or bosses on the trucks, and they are rotated by means of beveled gears on their lower ends, which engage like gearing on the horizontal driving-shaft, which is supported in suitable bearings in the pedestal A, and carries a center tight pulley and two side loose pulleys.

The pulley-bearing end of the shaft is supported in a bracket on the side of the pedestal, which bracket also supports the belt-shipper, hereinafter described.

To the trucks T T' are attached two sets of jaws. The lower crimping-jaws are attached by means of vertical hinges *h h'*, whereby they are allowed to slightly swing horizontally, which motion in the jaw D' is controlled or limited by the thumb-screws *a* on the front and back of the truck T'.

The jaw D is hung on hinges *h* to a rectangular box, F, which, within the truck T, has a lateral movement, which is effected automatically as the trucks move upward or downward—that is to say, moving toward the central plate or form as the trucks descend, thus effecting the pressure on the leather between the two jaws, and moving away from said plate when the trucks rise.

Both jaws, being hung on vertical hinges,

as above described, are free to adjust themselves to each other, to the varied thickness of the leather, or to the surface of the tree or the crimping-form N.

The manner in which the box F is moved is more clearly shown in Figs. 3 and 4.

Within the body of the truck T, in suitable recesses for the purpose provided, is the fulcrum of lever H, the long end of which projects outward, while the short end is at all times within said truck.

From the head of the machine projects downward into the body of said truck T' a bar, G, the upper end or shank of which is screw-threaded, and works in a screw-threaded sleeve, *g'*, fast to the cross-beam in the head of the frame. By means of a hand-crank, *g*, the bar G is made adjustable, to more or less project into the truck.

The arrangement of the bar is such as to come in contact, at a certain point of the elevation of the truck, with the short end of the lever H. When the truck is at its upper position—that is, before the leather is acted upon—the bar G is in contact with the shorter arm of the lever H within the truck T, elevating the long end. As the truck descends the short end of the lever H slides along the bar G until it reaches the end thereof, when, actuated by the weight I on the longer end, it will tilt and rise, causing the longer end of the lever H to be depressed and fall.

The shaft forming the fulcrum on which the lever H moves has a right and a left hand screw-thread cut on each end, respectively working in the truck T and in the rectangular box F. As, therefore, the long end of the sleeve H descends the screws force the box out, and with it the jaw D, toward the opposite jaw D'.

The weight I is arranged to slide upon the long end of lever H, so that at the beginning of the downward motion of the trucks it may be near the fulcrum of the lever, and that, as the trucks descend, they may be thrown out to press the jaws forward with increasing force.

This is effected by the means and in the manner as follows: To one side of the frame (preferably in the rear) is secured a raised or projecting track, M, parallel with the way K, upon which the truck T runs. To the part of this truck which embraces the way K is secured a bracket or sleeve holding a shaft, which carries on one end a tumbler, L, and on the other a crank, *l*. The former consists of a double shoe, having two sliding surfaces at an angle of about sixty degrees to each other in two different planes, one corresponding to that of the raised track M, the other to the face of the frame to which the track M is attached.

It will be understood that when the tumbler is opposite the track M the sliding surface corresponding to this track will be in contact with it, as shown in Fig. 3, and slide upon it until it shall have reached the lower end, when, actuated by weight, as will be presently described, it will, upon its axis, rotate and tumble over until arrested by the other sliding

surface on coming in contact with the face of the frame, as shown in Fig. 1. In thus rotating the tumbler describes an arc of a circle of about three hundred degrees. The shaft upon which the tumbler is rigidly mounted, rotating with the tumbler, causes the crank on its other end to describe a similar arc of a circle. This crank being connected with the weight I by means of a connecting-rod, *l'*, and the lever H, which carries the weight I, having its fulcrum at a fixed relation to the axis of the tumbler, as shown in the drawings, the operation will be as follows: When the lever H is in its uppermost position and the tumbler on the track, then the crank-pin, the joint of the connecting-rod with the weight I, and the fulcrum of the lever H will form a triangle of which the lever is the base. As the lever H descends the relative position of the fulcrum and crank-pin will remain the same so long as the tumbler keeps on the track. The weight I, however, will be shifted slightly toward the free end of the lever until the three points come as nearly as possible in one line; but when the tumbler reaches the end of the track, then, in turning over and describing with the crank an arc of a circle of about three hundred degrees, the weight will be rapidly pushed out toward the end of the lever now depressed. The weight thus thrown upon the end of the lever causes the right and left hand screw, which is actuated by the said lever, to press the jaw D toward the other jaw with an increased force at a point where it is safe and eminently useful to exert simultaneously great compressive and drawing action upon the leather.

The upper or smoothing jaws E E' are attached to the trucks T T' in the following manner: Both the jaws E and E' are secured at their lower ends by projecting hinge-joints, the jaw E by hinge *e*, which is movable, as hereinafter described, and the jaw E' by a fixed or immovable hinge, *e'*, and at their upper ends both jaws are attached to their respective trucks by toggle-joint levers, operated by the handles O O' to tilt the upper end of both or either of the jaws backward by depressing both or either of said handles.

The hinge *e* of the jaw E is attached to a box, P, operated by a lever, H', weight I', tumbler L', and screws, as already above described with reference to the lower jaw D. The fulcrum of this lever O is fixed to the truck T; but the links *o'* are connected to the box P, so that, independently of the tilting motion of its top, the jaw E is moved bodily by the above-mentioned lever, weight, cam, and screws toward its opposite jaw E', producing a pressure on the leather between them.

The tracks of the tumbler L' are arranged to cause the jaws E E' to press with increased pressure against each other after, when opposite the form, they shall have performed their work.

By the above arrangement of the mechanism of the two kinds of jaws, it will be seen

that they are hung independently of one another, that they open parallel to each other, that they are self-adjusting, and that they move with but little friction.

The adjustable bar G is attached to the upper portion of the machine, and is moved vertically by a screw within the boxing or sleeve g' worked by the handle g . The upper end of the bar projects downward, and as the trucks are being raised it enters a hole in the top of truck T, and, successively coming in contact with the short arms of the levers H' and H, depresses them. This bar is stationary during the process of crimping, but, by the handle g , can be elevated or depressed within narrow limits, so as to operate the levers H' and H, and through them the jaws E and D, earlier or later in the process of crimping, according as the thickness of the leather or other material requires.

The movement of the trucks at the upper and lower end of the stroke is arrested automatically, as follows: The main driving-shaft 1, which is provided with pinions 2 and 2', meshing in with pinions 3 3' on the vertical right-hand and left-hand screw-shafts B B', extends laterally from the frame of the machine, and carries three pulleys, 4, 5, and 6, the central one of which is fast. Two belts, running in opposite directions, are engaged in the rings 7 and 8 of bell-crank levers, having their fulcra upon a fixed or stationary frame or bracket overhanging the pulleys. Pins 9 and 10 on the end of shorter arms of these levers are engaged in a slot of peculiar formation in the sliding bar 11. The slot is so shaped that in shifting the bar 11 in its bearings the outer ends of the long arms of the levers—that is to say, the belt-carrying rings—will be shifted to bring either belt opposite the fast, and the other onto one of the adjoining loose pulleys. In this way, by merely shifting the slide-bar, the fast pulley may be made to engage with either belt, revolving in either direction. The shifting of the slide-bar is effected in this machine either by hand or by foot, or automatically. A curved rod, 12, connects the slide-bar at 13 with a vibratory lever, 14, which is pivoted at 15 on the fulcrum of a bell-crank, one end, 16, of which is free, while the other end, 17, is connected, by means of connecting-rod 18, to a similar bell-crank, 19, on top of the machine. These bell-cranks are arranged in the path of the trucks, so that when the latter reach the terminal position of their course a cam, 20, on either of them shall strike the free end of one of the bell-cranks and cause it to tilt, and thus operate the shifting-bar of the belt-carrying levers. When the trucks descend and the cam 20 strikes the lower bell-crank at 16, then the lever 14 will be forced to push the curved bar 12, so as to bring the belts over 5 and 6; but when the trucks ascend and the cam 20 strikes the upper bell-crank at 21, then the action will be reversed, and the belts shifted onto 4 and 5, so that, automatically, the belts are shifted at

the end of each stroke, and the action of the machine is reversed. To start the machine, or to work it, if necessary, by hand, I use a hand-lever, whose fulcrum is at 22, in a bracket fast to the face of the frame. The short end of this lever is secured to the connecting-rod 18, so that, by working the lever up or down, the belts are shifted in like manner as by the cam on the truck T'. To keep the machine at rest, both belts are run on the loose pulleys; and, in order to prevent the belts from accidentally shifting, I provide the hand-lever with a latch or locking device, consisting of a second hand-lever, q^1 , parallel with the first, so that both can be grasped by the operator at once. This second hand-lever q^1 is, by means of a spring, actuated to lodge in a notch in the stationary curved locking-plate 24. To release it the operator compresses the two handles, and the two levers may be worked in unison to shift the belts. To start the machine with the foot, leaving the hands free to adjust the leather to be crimped, I have provided a treadle, Q, which, by means of the rod q , operates an angular cam, 25, moving the handle q^1 toward the handle q^2 , thus freeing the catch, holding the handles in their central position, and, depressing them, shifts the belt and starts the machine.

The crimping-jaws are suitably corrugated, to crowd the leather toward the heel of the boot; but as there is a tendency to wrinkle where it doubles over the top of the tree N, I have devised, to obviate this, a wrinkle-preventer. This consists of a flat piece of metal, R, of the same thickness as the tree, pendent from a rod, R', that slides in guides r in the head of the machine. On the lower end of the rod R' is a cross-piece, r^2 , that is caught by the notch r^3 in the upper jaws E E' as they rise, thus lifting the wrinkle-preventer out of the way, to allow the leather to be placed in position to be crimped. As the jaws descend the lower end of the preventer, which conforms in shape to the upper edge of the tree N, comes in contact with the leather just before the upper jaws begin to act upon it, and during the remainder of the descent is firmly held in that position by suitable adjustable weights or springs applied to the top of the rod R'.

To operate the wrinkle-preventer automatically, I have devised the following arrangement of mechanism: After both jaws have wholly passed over the leather, the projection s on the side of the truck T (shown in dotted lines in Fig. 2) comes in contact with the end of the bent lever S, depressing the rod S' and liberating the catch S², when the weight V on the arm V¹ of the cam-lever falls, elevating the farther end V² of this lever, which, catching the pin v , Fig. 1, in the rod R', elevates the said rod, and with it the wrinkle-preventing plate R, allowing the latter to be removed. In the upward movement of the trucks the vertical projection W, coming in contact with the lower arm V³ of the three-way lever, gradually raises the weight V, allowing the rod R'

and wrinkle-preventer plate R to descend until the catch s^2 , moved by the spring s^3 , again engages the arm V³. The rod R' is, at the same time, raised by the cross-piece r^2 , elevating the wrinkle-preventer, as above described, while another piece of leather is being placed in position.

The bottom of the lower or crimping jaws D D' is made to conform with the shape of the top of the plate or tree N, whatever that shape may be, as more clearly shown in Fig. 3. The top of the jaws is nearly straight, so that they can still operate upon the corner or heel of the boot after they have passed over the leg and toe. This I find to be absolutely necessary in order to get all of the stretch out of the leather or other article, and make the corner of the boot long enough.

The tree or form N is supported on dove-tailed slides X, and moves with freedom laterally to respond to the position of the jaws. But instead of the tree being firmly fastened to the slide, I attach it by fitting it in a groove, held there firmly by a pin, x , on the front and back of the machine. By this arrangement the plate can readily and speedily be removed and another of the same or different shape substituted by simply removing the two pins x .

Having thus described my said invention, and the manner in which the same is or may be carried into effect, what I claim, and desire to secure by Letters Patent, is—

1. In machinery for crimping leather and other material for boots and shoes and other articles, the combination, with a crimping tree or plate, of jaws for crimping or smoothing the material, arranged in pairs, and mounted in trucks movable upon stationary and rigid ways, and mechanism for imparting lateral movement to said jaws toward each other, substantially as herein shown and described.

2. The combination, with the movable truck, of a jaw-carrying box, movable within said truck, substantially as herein shown and described.

3. The combination, with the movable truck and jaw-carrying box, of a right and left hand screw, forming the fulcrum of a lever, to be operated from without the truck, substantially as shown and set forth.

4. The combination, with the jaw-carrying box, operated to move within and transversely to the path of the truck by means of a right and left hand screw, of an automatically-operated lever to rotate said screw, substantially as herein shown and set forth.

5. The combination, with the movable truck on the stationary frame and the jaw, operated by a lever, as described, of an adjustable stop fast to a fixed portion of the frame, and actuating the lever within said movable truck to turn the screw at the proper intervals of time, substantially in the manner and for the purposes set forth.

6. The combination, with the jaw hung up

on a box operated by right and left hand screw and lever, of the automatically-shifted weight upon the lever, for operation substantially as and for the purposes set forth.

7. The jaws supported and hung substantially as herein shown and described, whereby each jaw of any pair of jaws may adjust itself independently of the other with respect to the crimping-tree, as herein set forth.

8. In a machine for crimping boots and shoes, the jaws hung to the trucks by means of links, substantially as herein and shown described.

9. The smoothing-jaws, arranged in opposite pairs, both being attached to their respective trucks by hinge-joints, substantially as shown and set forth, so as to admit of each being tilted upon its lower end, as described.

10. The smoothing-jaws, arranged in opposite pairs, the one being hinged at its lower end to the truck, while the lower end of the other is hinged to a box movable within the truck, both jaws having toggle-joint connections at their upper ends with their respective trucks, substantially as shown and set forth.

11. The combination, with the smoothing-jaws, hung at their upper ends to their respective trucks by means of toggle-joints, of levers to operate said toggle-joints for the spreading the jaws apart, substantially as and for the purposes set forth.

12. The combination, with one of a pair of smoothing-jaws, of the mechanism, substantially as described, whereby the hinge by which its lower end is secured to the truck is made automatically to move toward and away from the crimping-tree, as and for the purposes set forth.

13. The combination, with the belt-shifting device, of the system of levers, bell-cranks, and connecting-rods herein shown and described, operated by cam fast to one of the trucks, to shift the belts automatically, and to reverse the machine at the completion of either stroke, substantially as and for the purposes set forth.

14. In a crimping-machine, and in combination with the belt-shifting device and the means herein described for automatically operating the same, the hand lever and latch, with the angular cam and treadle to operate the same by hand or foot, at the pleasure of the operator, substantially as shown and set forth.

15. In boot and shoe leather crimping machinery, and in combination with the crimping-tree and crimping-jaws, and whether the latter are or not used in connection with smoothing-jaws, the wrinkle-preventer, the same consisting of a plate the lower edge of which conforms with the upper or crimping edge of the tree, the same being arranged for operation substantially as herein shown and described.

16. The combination, with the wrinkle-preventer, of automatic means, substantially as

herein shown and described, for lifting it off and dropping it upon the tree at the proper time, as herein described.

17. The crimping-jaws, shaped substantially as herein shown and described, so that their action upon the leather on the tree shall be continued on the heel or corner portion of the same after they shall have ceased to act upon the other portions of the leather.

18. The crimping-tree supports, made, sub-

stantially as shown and described, with lateral slides and with grooves to hold the plate therein, and pins or other fastening device, so as to allow of its ready removal and replacement.

In testimony whereof I have signed this specification in presence of two witnesses.

S. W. JAMISON.

Witnesses:

A. POLLOK,

A. B. WILLIAMS.