

F. KEENAN.  
Rock-Drilling Machine.

No. 198,625.

Patented Dec. 25, 1877.

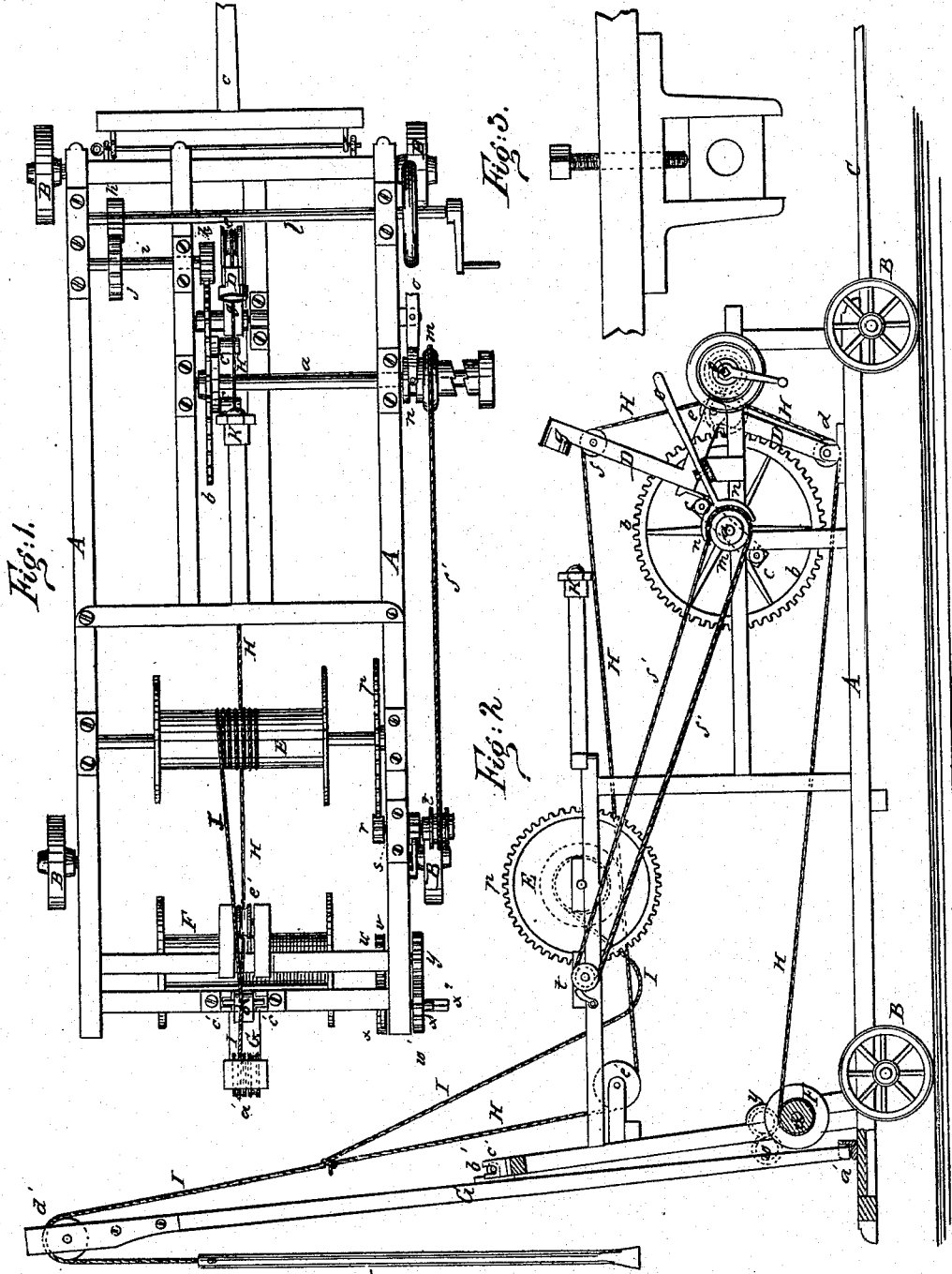

Witnesses:  
*Chas. Nida*  
*H. D. Wallenberg*

Inventor:  
*Franklin Keenan*  
per *W. H. G. M. A. H. G.*

# UNITED STATES PATENT OFFICE.

FRANKLIN KEENAN, OF BROWNVILLE, NEW YORK.

## IMPROVEMENT IN ROCK-DRILLING MACHINES.

Specification forming part of Letters Patent No. **198,625**, dated December 25, 1877; application filed October 24, 1877.

*To all whom it may concern:*

Be it known that I, FRANKLIN KEENAN, of Brownville, in the county of Jefferson and State of New York, have invented a new and Improved Rock-Drilling Machine; and that the following is a full, clear, and exact description of the same, reference being had to the accompanying drawings, and to the letters of reference marked thereon, making part of this specification.

This invention is in the nature of an improvement in rock-drilling machines; and the invention consists in a rock-drilling machine mounted on wheels, provided with a swinging mast supported by trunnions to its supporting-frame, and constructed with two windlasses, whereby the drill is fed and recovered from the drill-hole, and also constructed with an oscillating bell-crank provided with sheaves, in combination with cams, whereby the throw of the drill is effected and regulated.

In the accompanying sheet of drawings, Figure 1 is a plan or top view of my improved drill; Fig. 2, a side view, partly in section; and Fig. 3, a detail view of a modification for elevating or depressing the end of the carriage.

Similar letters of reference indicate like parts in the several figures.

A represents the bed or base of the frame-work of my drill. This base is supported on wheels B, and is also provided with a pole, C, so that the entire drill may be transported from place to place, together with all its operating mechanism and parts, with the same facility as can an ordinary wagon.

Secured to the base A, and supported by suitable frame-work at or near the rear end of the base, is a shaft, *a*, with a gear-wheel, *b*, affixed thereto, on which gear-wheel are cams or studs *c*, the shaft *a* resting in suitable bearings, in which it revolves.

Pivoted to the base A, at one end, is a bell-crank lever, D, which lever has fitted to it sheaves *d*, *e*, and *f*, and at its upper end a head, *g*.

Gearing into the gear-wheel *b* is a gear-wheel, *h*, fixed to a shaft, *i*, on which is also fixed a gear-wheel, *j*, which, in turn, gears into a wheel, *k*, fixed onto a driving-shaft, *l*; and onto the

outer end of the shaft *a* is a pulley-wheel, *m*, and clutch *n*, with clutch-lever *o*.

To suitable frame-work supported on the base A is a windlass, E, with a gear-wheel, *p*, affixed to it, which gear-wheel meshes into a gear-wheel, *r*, supported on a shaft, *s*, on which shaft is also a pulley-wheel, *t*; and also supported by suitable frame-work, and at the front of the base A, is a windlass, F, on the shaft *u* of which the gear-wheel *v* is fixed, which meshes into a gear-wheel, *w*, and that, in turn, into a gear-wheel, *x*, the gear-wheel *x* being secured to a shaft, *x*<sup>1</sup>, which shaft has a square, *x*<sup>2</sup>, formed upon its outer end, and has also upon said outer end a gear-wheel, *w*'. The gear-wheel *w*' meshes into a gear-wheel, *y*.

At the extreme front of the base A is placed a supporting-mast, G, the lower end of this mast resting into a shoe, *a*'. This mast is provided with trunnions *b*', by which it is supported in suitable bearings *c*', which bearings are secured to the supporting frame-work of the drill. The upper end or head of the mast G is fitted with a pulley or sheave, *d*'.

Now, my drill being constructed substantially as I have above described, its operation is as follows: Power of any suitable kind being applied to the driving-shaft, *l*, it is caused to revolve, and, through the gear-wheels *h*, *j*, and *k*, the gear-wheel *b* on the shaft *a* is caused to revolve. As this gear-wheel revolves, the cams or studs *c* thereon successively come in contact with the bell-crank lever D, and thereby cause the lever to be thrown backward on its lower pivot, and by its backward throw draws the line H, which line is wound upon the windlass F at one of its ends, and which passes around the bell-crank lever resting in the sheaves *d*, *e*, and *f*, and extending thence forward against a pulley-block, *e*', over the sheave *d*' in the head of the mast G, after which its other end is secured to a line, I, one end of which last-mentioned line being fastened to the head of the drill J, the other end being wound about the windlass E. The action of the cams or studs *c* on the gear-wheel *b*, as before stated, throws the bell-crank lever D backward, and by so doing the line H is made taut, and thereby draws the drill J upward to a height equal to the distance that the

bell-crank lever D is thrown backward by the action of the cams or studs *c*, each cam or stud throwing the bell-crank lever backward once, so that the lever is thrown back twice in each revolution of the gear-wheel *b*. When the cams or studs have passed the point of contact with the bell-crank lever, the weight of the drill causes it to drop in contact with the rock to be drilled, and gives the necessary cutting blow, and as the drill drops by its own gravity the line H is tightened and the bell-crank lever D restored to its vertical position, in which position it remains until again thrown back by the action of the cams or studs *c*, as before described. In this way an alternate up-and-down motion of the drill is obtained with facility.

As the drill is operated in the manner just described, the attendant of the drill, or drill-man, stands at the head of the base A, and, with a crank fitted on the square *x*<sup>2</sup>, slightly turns the windlass F, and in this way enables the drill to gain a little in its descent on each downward stroke, which constitutes the feed of the drill.

At each forward and vertical position of the bell-crank-lever, the head *g* fitted thereon is brought in contact with an elastic bumper, K, which receives the force of the forward blow, and which retains the bell-crank lever in its vertical position.

When it becomes necessary to withdraw the drill from the drill-hole, or to elevate it for any purpose whatever, the pulley *m* on the shaft *a* is clutched on the shaft, when, by means of an endless chain, *f'*, extending from the pulley *m* to the pulley *t*, the line I is reeled up on the windlass E, by which means the drill is raised to any desired extent up the mast G.

When not in use, the mast G may be instantly unshipped or tipped over on its trunnions, and the drill and jars run in onto the

base of the frame A, which will also carry the drills, crow-bars, wrenches, and other implements used in the operation of drilling, so that it can be transported with the entire mechanism, since, as before stated, the entire structure is on wheels, and is provided with a pole, to which a team may be hitched.

It will be desirable to construct the axles of the supporting-wheels with set-screws or other similar contrivances, to enable the drill and its carriage to maintain their proper position when being worked on uneven surfaces. A modification of such construction is shown in Fig. 3.

The gear-wheels *r*, *v*, *w*, *w'*, and *x* are merely to facilitate the revolving of the windlasses E and F, and the gear-wheels *h*, *j*, and *k* to facilitate the turning of the shaft *a* and transmitting the power to it.

Having now described my invention, what I claim as new, and desire to secure by Letters Patent, is—

1. A rock-drilling machine constructed with a supporting-platform on wheels, a swinging and removable mast to support the drill-cord, a bell-crank lever, in combination with a cam-wheel, whereby the drill is advanced or retracted, an elastic bumper to receive and limit the forward throw of the bell-crank lever, a windlass whereon is placed the operating-cord of the drill, and a second windlass, whereon is placed a feed-cord, and whereby the feeding of the drill may be regulated, substantially as described.

2. In a rock-drilling machine, a bell-crank lever, in combination with an elastic bumper, substantially as and for the purpose described.

FRANKLIN KEENAN.

Witnesses:

C. S. POTTER,  
J. G. GLENN.