

L. MORGENTHAU.  
Paper-Feeding Machine.

No. 198,662.

Patented Dec. 25, 1877.

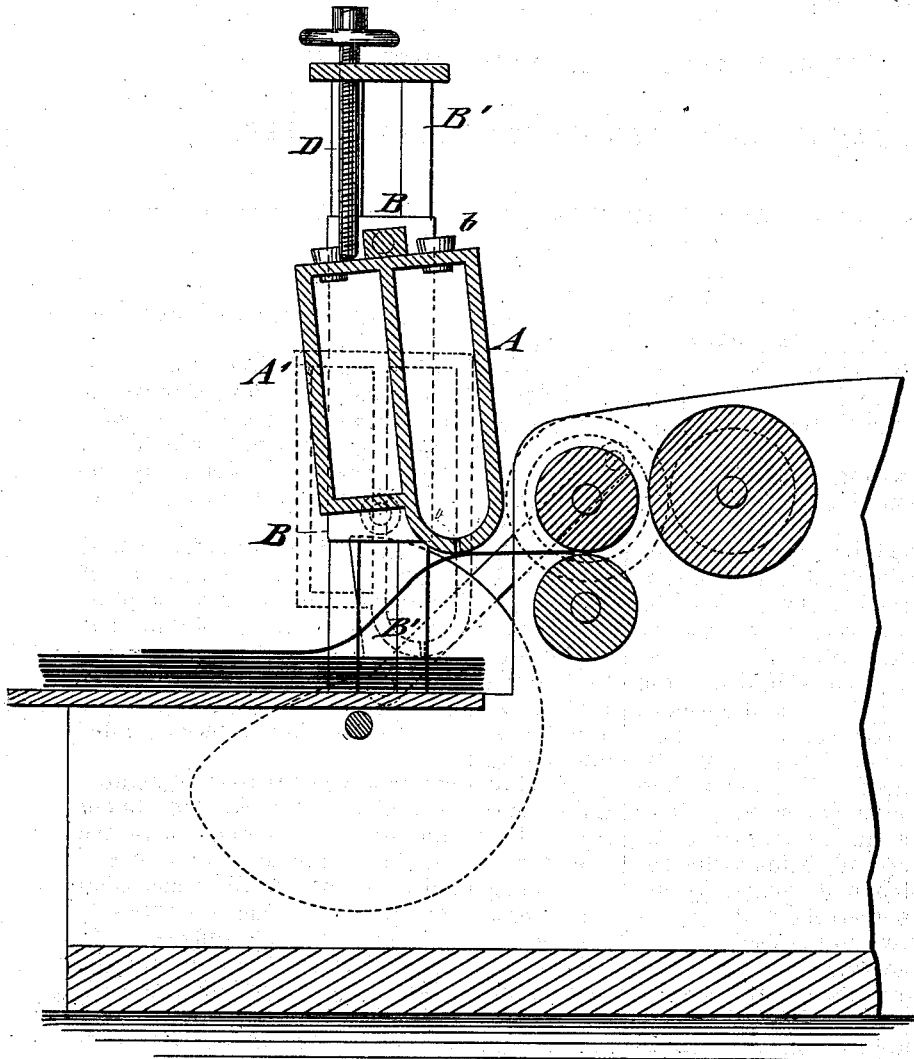

WITNESSES:

*Chas. Nida*  
*Alex F. Roberts*

INVENTOR:

*L. Morgenthau*  
BY *Heunt & Co*

ATTORNEYS.

# UNITED STATES PATENT OFFICE.

LAZARUS MORGENTHAU, OF NEW YORK, N. Y.

## IMPROVEMENT IN PAPER-FEEDING MACHINES.

Specification forming part of Letters Patent No. **198,662**, dated December 25, 1877; application filed November 10, 1877.

### *To all whom it may concern:*

Beit known that I, LAZARUS MORGENTHAU, of the city, county, and State of New York, have invented a new and Improved Paper-Feeding Apparatus, of which the following is a specification:

The accompanying drawing represents a vertical longitudinal section of my improved paper-feeding apparatus.

This invention is designed to furnish for power-printing-presses of all kinds, lithographic presses, labeling-machines, and for other purposes, an improved apparatus by which the sheets of paper, cotton, silk, or other material may be taken up and supplied to the feed rolls or cylinder in reliable and effective manner; and the invention consists of a vertically-reciprocating and oscillating casing or receptacle, that is arranged with a narrow longitudinal slot at the convexly-curved bottom, and filled with some adhesive substance, for the purpose of taking up and lifting a sheet of material at the downstroke of the receptacle, and carrying it by the upstroke and by contact with a top stop-screw to the feed-rolls, so as to be taken up by the same.

Referring to the drawing, A represents a hollow casing or receptacle, of suitable size, that is pivoted at the upper end to vertically-guided slide-pieces B, moving in slotted standards B'. The slide-pieces are raised and lowered by cams, or equivalent mechanical means, bearing on anti-friction rollers of the slide-pieces. The cams are so shaped that they produce a quick upward motion of the receptacle A, retain the same for the required length of time in raised position, and drop it instantly when a sheet has to be fed.

The hollow receptacle A is made rounded off at the bottom, with a narrow longitudinal slot, *a*, at the lowermost point, and filled with wax or other suitable adhesive substance having the required degree of consistency. The adhesive material is placed into the receptacle by means of an opening at the top, which is closed by a suitable plug, *b*.

The receptacle A may be provided at one side thereof with a jacket, A', that is to be filled with hot water, steam, or other heating agent, for the purpose of imparting, in cold weather, to the wax or other adhesive substance

in the main receptacle, the required degree of consistency.

The bottom of the side jacket A' is above the level of the rounded-off bottom of the main receptacle, so as to prevent the adhesive substance from assuming a too soft state above and near the issuing-slot, and also so as not to interfere with the regular working of the apparatus.

The water or steam may be supplied to and conducted off from the jacket by means of flexible or other pipes, and the water kept at a suitable temperature, so as to obtain that degree of softness in the adhesive material that is necessary for the proper taking up of the sheets. The wax may be kept in position and fed to the slot by suitable interior guides and springs.

The sheets are arranged between adjustable guides of the feed-table, and successively taken up by the contact of the receptacle with the sheets on the rapid dropping or downstroke of the receptacle, the force of the concussion allowing a small quantity of the adhesive substance to pass through the slot sufficiently to take up a sheet and raise it by the upward motion of the receptacle. The quick upward motion of the receptacle is interrupted and changed into an oscillating motion by the contact of the top part of the jacket or receptacle with an adjustable stop-screw, D, that turns in the cross-piece of the side standards B', and acts on the receptacle a short distance back of the pivots of the same. The contact with the stop-screw throws the receptacle, together with the sheet adhering thereto, forward toward the feed-rolls or other device, so that the paper is taken up and conducted on the printing-cylinder, or to the stones, or to the printing-rolls, as the case may be.

The weight of the receptacle and slide-pieces imparts to the downstroke a considerable power, so as to supply a small quantity of adhesive substance to the issuing-slot, said quantity, however, being, on account of the partial vacuum in the upper part of the receptacle, just sufficient to lift a sheet and feed it to the feed rolls or cylinder, but not enough to be perceptible on the surface of the paper.

The use of this feeding apparatus in connection with all kinds of printing and other

machines furnishes an automatic feed that may be run at the same speed with the machine, and that dispenses with the hands required at present to feed the sheets.

Having thus described my invention, I claim as new and desire to secure by Letters Patent—

1. A feeding apparatus for power printing and other machines, consisting of a vertically-reciprocating and oscillating hollow casing or receptacle containing an adhesive substance, and having a narrow longitudinal slot at the lowermost point, for the purpose of projecting a small quantity of adhesive substance at each downstroke, taking up the sheet and conducting it to the feed rolls or cylinder, substantially as and for the purpose set forth.

2. In a feeding apparatus for power printing

and other machines, the combination of a vertically-reciprocating and pivoted receptacle, containing a suitable adhesive substance, with an adjustable top stop-screw arranged back of the pivots, to impart oscillating motion to the receptacle at the end of the upward stroke, substantially as described.

3. In a paper-feeding apparatus, a hollow receptacle containing an adhesive substance, and having a rounded-off and longitudinally-slotted bottom part, in combination with a hot-water or steam jacket terminating above the rounded-off bottom, substantially as specified.

LAZARUS MORGENTHAU.

Witnesses:

PAUL GOEPEL,  
C. SEDGWICK.