

C. C. RICHMOND.  
Lamp-Burners.

No. 198,683.

Patented Dec. 25, 1877.

Fig. 1.

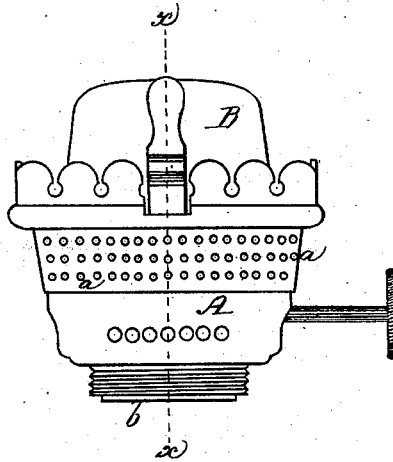

Fig. 3.

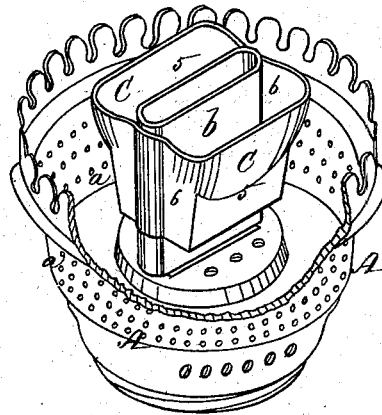
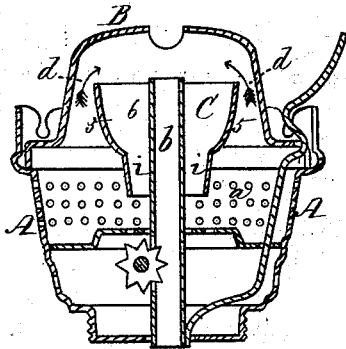

Fig. 2.



Witnesses,  
W. J. Cambridge  
J. E. Cambridge

Inventor,  
Charles C. Richmond  
per Verhagen & Stearns  
Atty's

# UNITED STATES PATENT OFFICE.

CHARLES C. RICHMOND, OF BOSTON, MASSACHUSETTS.

## IMPROVEMENT IN LAMP-BURNERS.

Specification forming part of Letters Patent No. **198,683**, dated December 25, 1877; application filed July 19, 1877.

*To all whom it may concern:*

Be it known that I, CHARLES C. RICHMOND, of Boston, in the county of Suffolk and State of Massachusetts, have invented an Improvement in Lamp-Burners, of which the following is a full, clear, and exact description, reference being had to the accompanying drawings, making part of this specification, in which—

Figure 1 is a side elevation of a lamp-burner constructed in accordance with my invention. Fig. 2 is a vertical section on the line *xx* of Fig. 1. Fig. 3 is a perspective view of the burner with the cone or deflector removed.

Lamp-burners have been constructed in which a short tapering sleeve, open at the top and bottom, has been applied to the upper end of the wick-tube, to serve as a conductor for directing or conveying a supply of air to the flame, to render the combustion more perfect. This device is, however, objectionable, as the strong upward currents of air passing up through the sleeve, impinge directly upon the top of the wick-tube, and tend to cool it, and thus retard the upward flow of the oil through the wick.

My invention has for its object to overcome this difficulty, and enable me to supply the requisite amount of oxygen to produce perfect combustion with light or heavy oils, without cooling the top of the wick-tube, as heretofore; and consists in the employment of an adjustable sleeve, made in the form of an inverted bell, in connection with the wick-tube and cone or deflector, an air-space being left between the upper edge of the sleeve and the interior surface of the cone, by which construction the greater portion of the oxygen necessary to support combustion is forced to pass up outside the sleeve, and through the space between its upper edge and the interior of the cone, only a small portion of the air necessary to support combustion being conducted up inside the sleeve, whereby more perfect combustion is effected and the cooling of the wick-tube avoided, while by adjusting the position of the sleeve the width of the space between its upper edge and the interior of the cone can be increased or diminished, and its shape varied, in order to regulate the supply of oxygen for oils of different degrees of density.

To enable others skilled in the art to under-

stand and use my invention, I will proceed to describe the manner in which I have carried it out.

In the said drawings, A represents the outer casing of a lamp-burner, which is provided, as usual, with perforations *a* for the admission of air. *b* is the wick-tube, and B is the detachable cone or deflector, all of the ordinary construction.

Over the upper portion of the wick-tube *b* is placed a short sleeve, C, provided at its ends with grooves, which fit the edges of the wick-tube on which the sleeve slides, the friction between the sleeve and wick-tube being sufficient to hold the former in place upon the latter when adjusted in the desired position.

The sleeve C is made in the form of an inverted bell, the two opposite wider sides *5* tapering or flaring upward and outward, and the two opposite narrower sides *6* also tapering upward and outward, but to a less degree than the wider sides, while the upper corners are slightly rounded, as seen in Fig. 3.

The upper edge of the sleeve extends up all around into close proximity with the interior surface of the cone B, as seen in Fig. 2, thus leaving an air-space, *d*, between the two, and consequently the greater portion of the atmospheric air necessary to maintain combustion is compelled to pass up outside of the sleeve C, and through the space *d*, and over the upper edge of the sleeve to the flame, the peculiar construction of the sleeve allowing but a very small quantity of the air necessary to support combustion to pass up through the spaces *i i* between it and the opposite sides of the wick-tube; and this air, which passes up through the spaces *i i*, owing to the outwardly-flaring sides of the sleeve, is not directed so as to impinge upon the top of the wick-tube, which is not, consequently, cooled thereby, as heretofore, while, by causing the air to pass through the space *d*, the force of the upward currents is diminished, and the air passing up through the spaces *d i* is delivered uniformly, and in such quantities as to secure the most perfect combustion with either light or heavy oils.

The shape of the upper edge of the sleeve C must be varied according to the shape of the cone or deflector employed, so as to afford an air-space, *d*, between the two of a size

and shape best adapted to supply the requisite quantity of air to the flame at the desired points, in order to produce the best results, and by adjusting the sleeve C upon the wick-tube the width of the air-space *d* can be increased or diminished, and its shape varied; and by this means the quantity of oxygen supplied to the flame over the upper edge of the sleeve C can be regulated in accordance with the density of the oil employed.

Instead of attaching the sleeve to the wick-tube, it may be secured, by light wires or otherwise, to the interior of the top of the cone B, in such a manner as to leave the air-space *d*; but with this latter construction the sleeve would not be adjustable, and, conse-

quently, I prefer to attach the sleeve to the wick-tube, as first described.

What I claim as my invention, and desire to secure by Letters Patent, is—

The adjustable sleeve C, of the form of an inverted bell, and having an outer passage or space, *d*, between it and the cone B, and an inner passage or space, *i*, between it and the wick-tube *b*, on each side thereof, substantially as and for the purpose set forth.

Witness my hand this 14th day of July, A. D. 1877.

CHARLES C. RICHMOND.

In presence of—

P. E. TESCHEMACHER,  
N. W. STEARNS.