

H. B. SMITH.  
Labeling-Machine.  
No. 198,700. Patented Dec. 25, 1877.

Fig. 1.

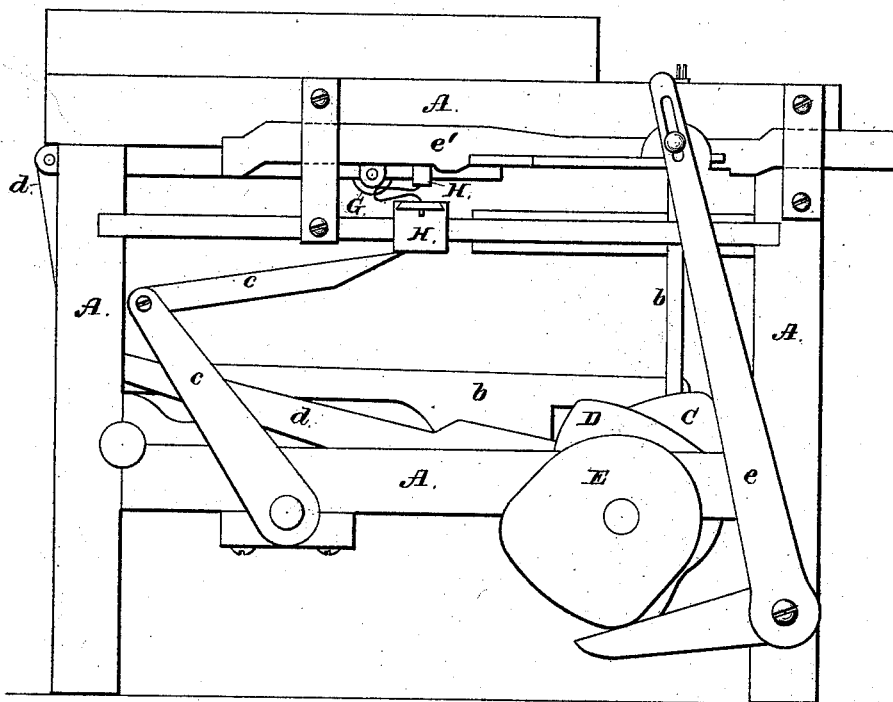
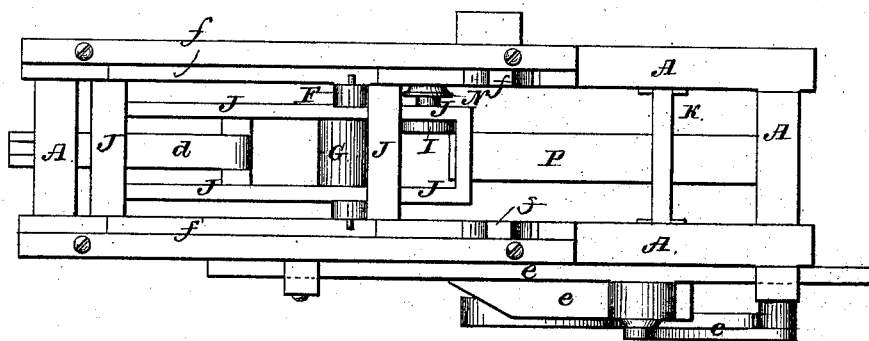

Fig. 2.



Attest.

Bennett W. Morse  
R. H. Kidmore Jr.

Inventor.

Harris B. Smith.

H. B. SMITH.  
Labeling-Machine.

No. 198,700.

Patented Dec. 25, 1877.

Fig. 5.

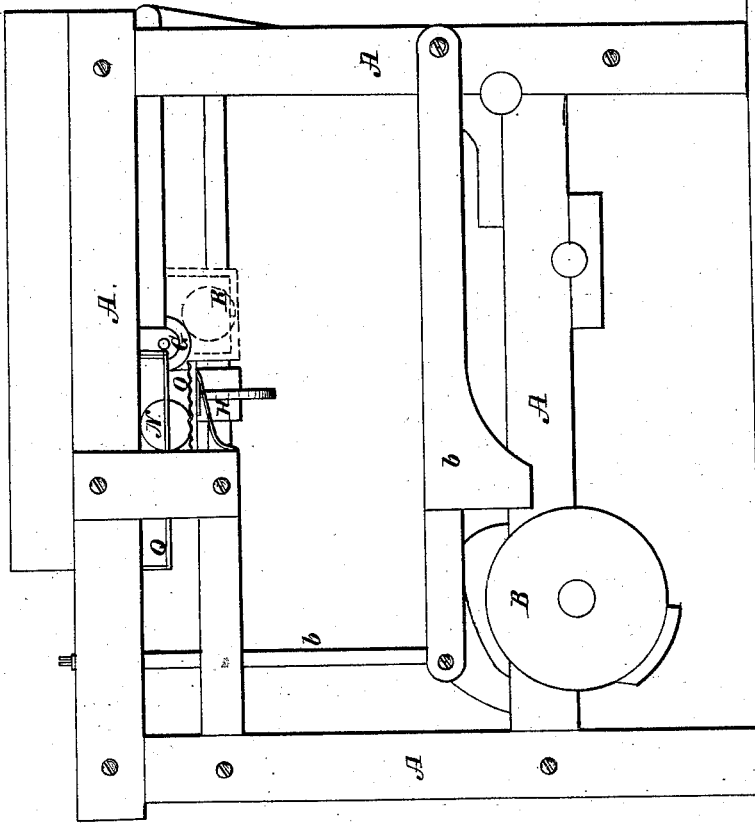

Fig. 4.

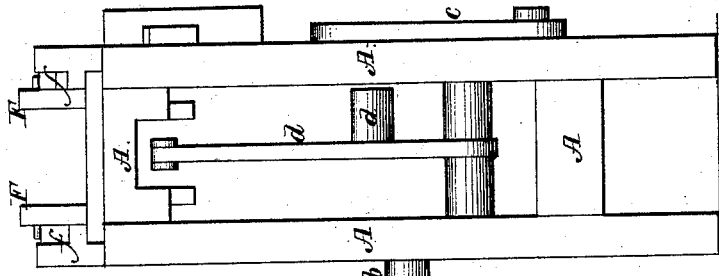
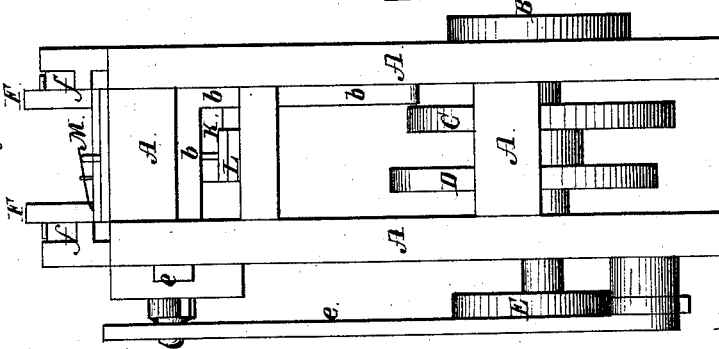

Fig. 3.



Attest.  
Bennett W. Morse  
P. Hecklinger Jr.

Inventor.  
Harris B. Smith

H. B. SMITH.  
Labeling-Machine.

No. 198,700.

Patented Dec. 25, 1877.

Fig. 6.

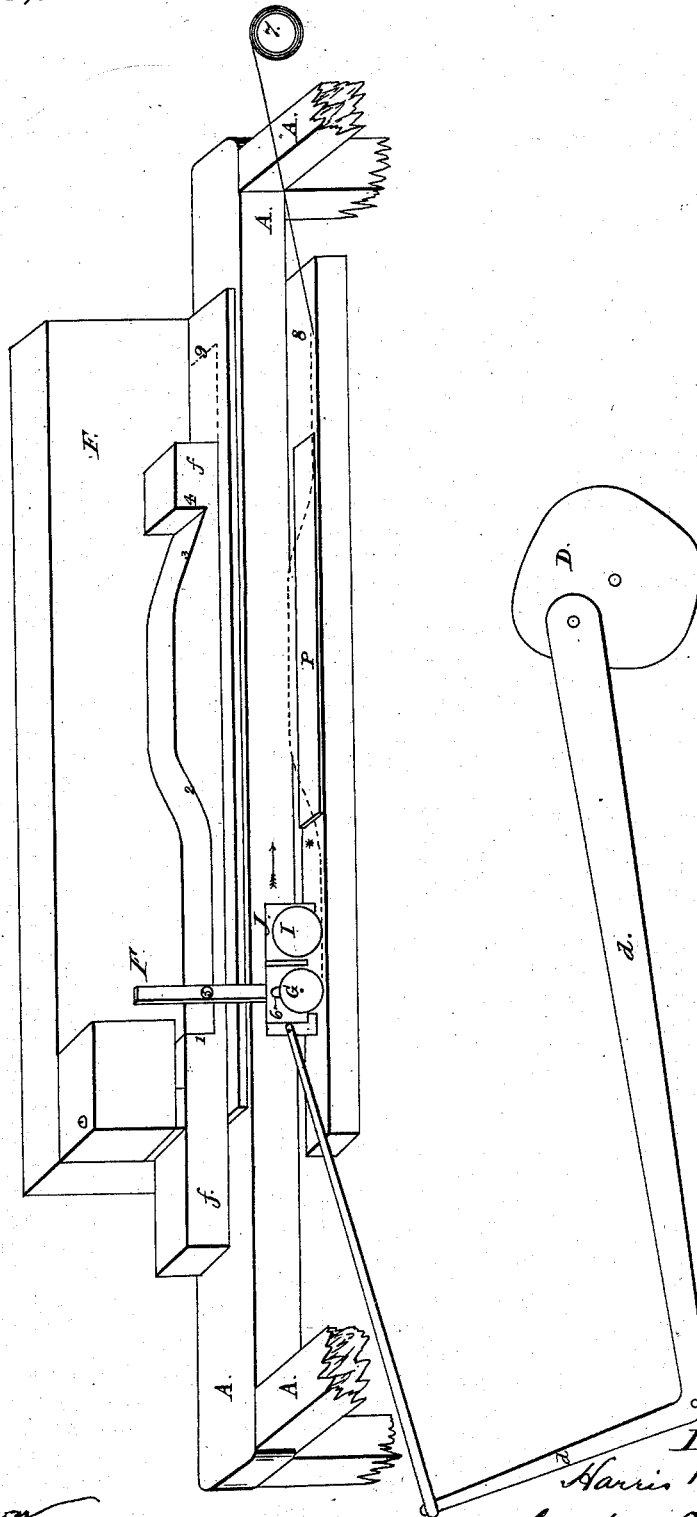

Witnesses:

*A. P. Low*  
*Geo. Bacon*

Inventor:  
*Haris B. Smith*  
by *Wm. H. Pinckel*  
*att'y.*

# UNITED STATES PATENT OFFICE.

HARRIS B. SMITH, OF BRIDGEPORT, CONNECTICUT.

## IMPROVEMENT IN LABELING-MACHINES.

Specification forming part of Letters Patent No. **198,700**, dated December 25, 1877; application filed October 19, 1877.

### *To all whom it may concern:*

Be it known that I, HARRIS B. SMITH, of Bridgeport, in the county of Fairfield and State of Connecticut, have invented a new and Improved Machine for Labeling Cans, Boxes, and other things cylindrical in form; and I do hereby declare that the following is a full, clear, and exact description thereof, which will enable others skilled in the art to make and use the same, reference being had to the accompanying drawings, forming a part of this specification.

Figures 1 and 5 of the drawings represent the two side elevations, the latter partly in section, of my invention. Fig. 2 of the drawing represents the top elevation, partly in section, of my invention. Figs. 3 and 4 of the drawings represent the end elevation, partly in section, of my invention.

Letters of reference indicate corresponding parts.

This invention relates to a new apparatus for labeling cans, boxes, &c., cylindrical in form.

A represents the frame of the machine. B is the eccentric for working the levers or arms attached to the cut-off for the labels. *b b* are the levers or arms worked by the eccentric B. C is the eccentric for working the arm which carries the label forward. *c c* are the levers or arms worked by the eccentric C. D is the eccentric for moving the car and its attachments, which carries the article to be labeled and the paste-roller. *d d* are the levers attached to the car and worked by the eccentric D. E is the eccentric for working the nippers (opening and closing them) which hold the label. *e* is the lever worked by eccentric E. *e'* is a horizontal bar worked by the lever *e*, the elevations and depressions on the same working directly on the nippers H. F represents adjustments for raising and lowering the paste-roller G, as shown in Fig. 2, whereby the paste is applied to the ends of the labels only, if so desired, and the arrangement is such that the paste is first applied to the end of the label nearest the cut-off, and afterward to the other end, by which means the label is never picked up by or rolled upon the paste-roller, but retains a smooth position upon the pad P until it is taken up by the article being labeled.

Fig. 6 is a perspective view of part of the interior of one side of the machine. This figure represents the machine at rest at one end of its motion, let it be presumed. As soon as motion is imparted the car J moves in the direction indicated by the arrow, and the paste-roller G is carried along in a horizontal course, as indicated by the dotted line, until it reaches the spot marked with an \*. At this point the little roller numbered 5 runs up the incline 2 on piece *f*, and raises the paste-roller G from pad P, and while the paste-roller is thus suspended, as is further shown by the dotted line already mentioned, the nippers H grasp the end of the label or roll of paper at about the spot indicated by the figure 8, and carry it under the paste-roller G to its place on pad P. The nippers, of course, are worked by a separate eccentric and set of levers, and retain their hold upon the label while the car J and its attachments finish their stroke. Now, the paste-roller keeps on its course, and when roller 5 reaches the foot of incline 3 or piece *f* it (the paste-roller) rests upon the label a short distance from its end. The little roller 5 now comes against the shoulder 4, presses directly against it, and thus pushes piece *f* along its bed or track to the dotted line 9, pasting the label from the place where the roller first touches it to its end. The machine having now completed its motion in this direction is reversed by the revolution of the eccentric D, and immediately the little roller 5 runs up the incline 3 on piece *f*, raising the paste-roller from the label, and it is not brought into contact with it again until roller 5 runs down incline 2. It then pastes the other end of the label in the same way as the first end spoken of was pasted, and when this is finished roller 5 butts against shoulder numbered 1, and carries piece *f* back to the place where it was when the machine first started. At this point roller G gets a fresh supply of paste from a reservoir provided for the purpose, and is again ready to repeat the operation.

G is the paste-roller. H are the nippers for grasping the label. I represents a friction wheel or clutch, which runs in connection with wheel or pinion N, in which or against which the article being labeled is placed or has a bearing, the revolution of the said friction

wheel or clutch being so regulated that the needful rotation is given to the article being labeled more rapid than it would naturally have in rolling over the pad P. J is the car, carrying the article to be labeled and the paste-roller G. K represents a knife for cutting off the labels, they being printed on a roll or belt of paper. L is a pad attached to the knife adjustment, which holds the belt or roll of paper while the knife K cuts off the label to be used, and the nippers H carry it to and drop it on pad P. M is a spring for holding the pad L firmly upon the roll or belt of paper while the knife K is completing its motion. N is a wheel, running, in connection with the friction wheel or clutch I, over the cog-plate O, or with a band or other suitable device for rotating the friction wheel or clutch I, and giving the article being labeled a more rapid revolution over the pad P than the motion of the car would naturally give it. O represents the cog-plate. P is the pad on which the label lies when dropped by the nippers H, and while being taken up by the article being labeled. Q is a spring attached to frame A, for pressing the friction wheel or clutch I hard against the article being labeled, causing sufficient

friction to give the desired revolution. R is a box and roller for supplying the paste-roller G with paste.

By this invention the tedious process of labeling by hand will be overcome, while at the same time the labels will be applied more evenly and without becoming soiled by handling.

Having thus described my invention, I claim as new and desire to secure by Letters Patent—

1. The combination of the friction-clutch I, pinion N, and rack O with the car J of a label-attaching machine, whereby a rapid rotary motion is imparted to the article being labeled, substantially as shown and described.

2. The combination of the bars *ff*, paste-roller supports F F, and paste-roller G with the car J, substantially as shown and described.

3. The combination of the car J, paste-roller G, supports F F, bars *ff*, and nippers H with means, substantially as described, to operate them, as and for the purpose shown and specified.

HARRIS B. SMITH.

Witnesses:

BENNETT W. MORSE,  
P. H. SKIDMORE, Jr.