

W. E. THORNTON.  
Pipe-Wrench with Cutter.

No. 198,709.

Patented Dec. 25, 1877.

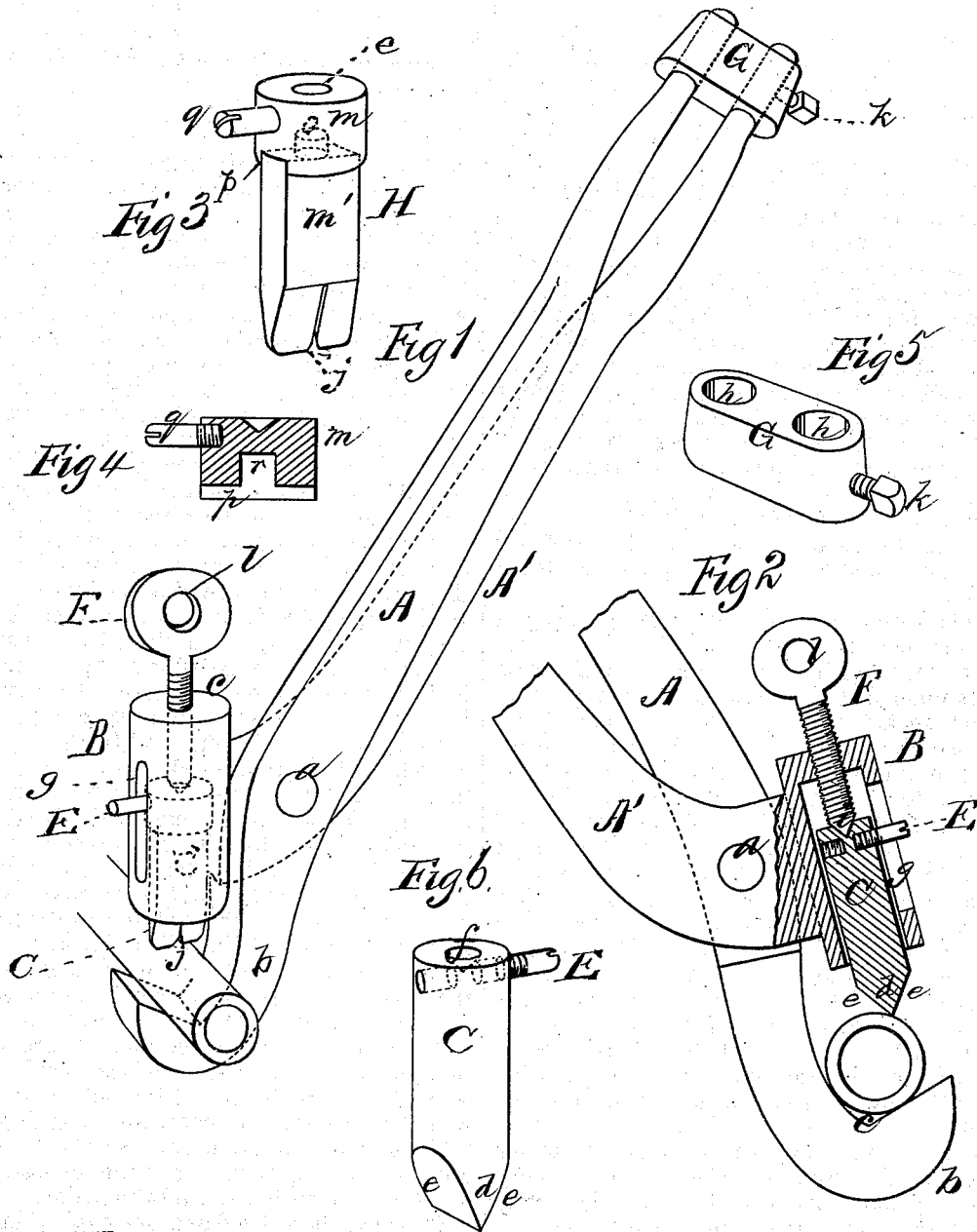

WITNESSES  
*Villette Anderson*  
*F. J. Masi*

INVENTOR  
*William E. Thornton,*  
*by E. M. Anderson,*  
ATTORNEY

# UNITED STATES PATENT OFFICE.

WILLIAM E. THORNTON, OF PHILADELPHIA, PENNSYLVANIA, ASSIGNOR  
TO PANCOAST & MAULE, OF SAME PLACE.

## IMPROVEMENT IN PIPE-WRENCH WITH CUTTER.

Specification forming part of Letters Patent No. 198,709, dated December 25, 1877; application filed  
November 16, 1877.

To all whom it may concern:

Be it known that I, WILLIAM E. THORNTON, of Philadelphia, in the county of Philadelphia and State of Pennsylvania, have invented a new and valuable Improvement in Combined Pipe Tongs and Cutter; and I do hereby declare that the following is a full, clear, and exact description of the construction and operation of the same, reference being had to the annexed drawings, making a part of this specification, and to the letters and figures of reference marked thereon.

Figure 1 of the drawings is a representation of a perspective view of my improved pipe-tongs. Fig. 2 is a side view of the same, showing the socket, adjustable bit, and screw in section; and Figs. 3, 4, 5, and 6 are detail views.

This invention consists in a pipe cutting and holding tool, in combination with a lever having a recurvate hook with an annular recess in its inner face, also a lever having a cylindrical socket provided with a longitudinal slot, a chisel with a divided edge, and a head-piece provided with a guide-pin, as will be hereinafter more fully shown and described.

In the annexed drawings, the letters A A' designate the lever-arms of my improved pipe tongs and cutter, pivoted together, as usual, at *a*. Lever A will have at its biting end a recurvate hook, *b*, the upper or inner face of which will have an angular recess, *c*, and lever A' a tubular enlargement or socket, B, which will be cylindrical as to its bore, open at its lower end and closed at its upper end, as shown at *e*, Fig. 1. The longitudinal axis of the bore of enlargement or socket B will, when the tongs are closed, fall at the angle of recess *c*.

C designates a cylindrical steel bit, fitting snugly in the bore of socket B, and having free endwise movement therein. This bit, which has the function of a gripping-jaw, is provided at one end with a double-beveled edge, *d*, the faces *e* of which are at an angle of fifty degrees, or thereabout, to the longer axis of the bit, and in the other with a depression, *f*. It is also prevented from rotating in its socket by means of a check-pin, E,

passing through an oblong slot, *g*, in the wall of the said socket, and screwed into a perforation in the said bit.

F represents an adjusting-screw, which passes through a screw-threaded opening in the closed end of the socket, and has its free end bearing against the upper end of the bit. This screw has its lower end *i* shaped to correspond with the recess or depression *f* in the said bit, and centers accurately therein, thus bringing the pressure of the screw in line with the longitudinal axis of the bit aforesaid. By setting up screw F the bit or jaw C will be forced outward from the socket, and the pipe having been seated in the recess *c* of the fixed jaw *b*, the said pipe will be rigidly gripped by the tongs. As it is evident that the movable bit bearing against the pipe would be ineffective, as far as regards the clamping of the pipe, if the power-arms of the levers A A' were allowed to be free, I have connected them by means of a removable metallic link, G, having spaced perforations *h*, in which the ends of the said levers are adapted to be received. This link will be held against casual detachment by means of a set-screw, *k*, passing through a threaded perforation in the link-wall, and bearing against one of the lever ends. Screw F will have an enlarged perforated head, *l*, by means of which a leverage may be obtained for the more effectual actuation of the adjustable jaw.

By removing the guide-pin E and throwing open the tongs, bit C may be removed, or turned completely around. Consequently, as one of the faces of the edge *d* is worn away by continued use, a fresh surface may be presented to the periphery of the pipe, and such wear utilized for automatically keeping the said edge in condition for use, the gradual abrasion of one surface serving to keep the opposite face with a sharp biting-edge.

This device is utilized as a pipe-cutting implement by removing the bit C, and substituting therefor a chisel, H, which I prefer to make in two parts, one of which, *m*, will be the head, and the other, *m'*, the cutter. The latter will have a cylindrical tang, *o*, and will be received into a diametrical groove, *p*, on the under side of

the head, the said tang being at the same time admitted into a central opening, *r*, in the said head.

The chisel will be passed into the socket from below, and will be prevented from rotating by a screw, *q*, passing through the slot *g* in the socket into a threaded perforation in the head *m*. It will be capable of adjustment in the same manner as the bit above described, and will have a double-beveled cutting-edge. It will also have a slit, *r*, at or near the center of the cutting-edge, and extending as far as the bevels thereof, by which means the said edge will be prevented from being turned during use.

In practice I shall divide the cutting-edge into two equal or nearly equal divisions by means of a transverse notch, *j*, the object of which is to prevent the said edge from turning, whereby the cutter is made more effect-

ive. This notch may extend from the cutting-edge as far as the bevels extend.

What I claim as new, and desire to secure by Letters Patent, is—

In a pipe cutting and holding tool, in combination with the lever *A*, having the recurvate hook *b*, with angular recess *c* in its inner face, the lever *A'*, having a cylindrical socket, *B*, provided with the longitudinal slot, the chisel *H*, with divided edge *j*, and the head-piece *m*, provided with a guide-pin, *q*, substantially as specified.

In testimony that I claim the above I have hereunto subscribed my name in the presence of two witnesses.

WILLIAM E. THORNTON.

Witnesses:

GEO. C. SHELMEKDINE,  
ALLEN H. GANGEWER.