

D. C. EBAUGH.
Disintegrating or Mixing Machine.

No. 198,764.

Patented Jan. 1, 1878.

Fig 1

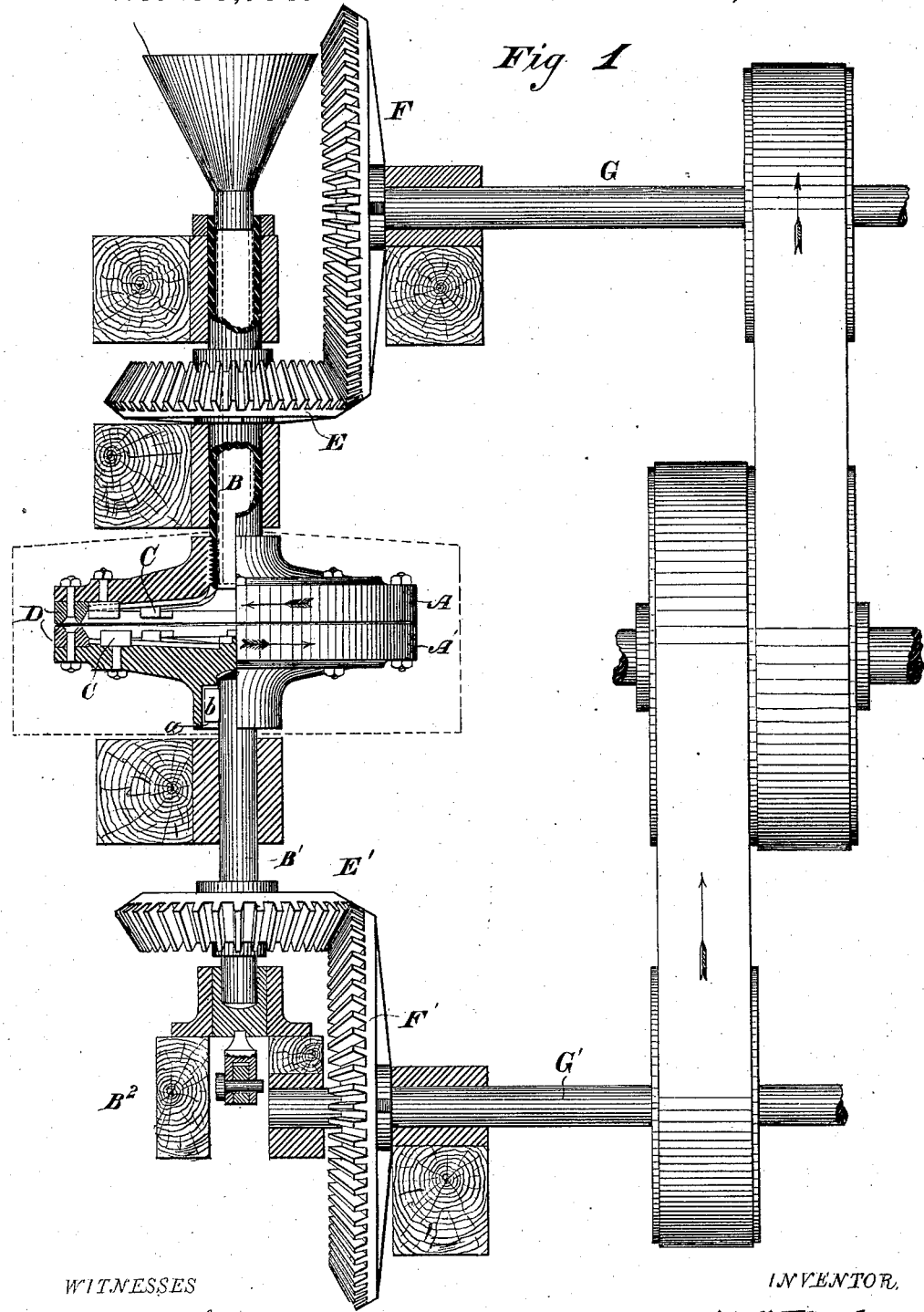

WITNESSES

Wm A. Skinker
Geo W. Beck

INVENTOR,

David C. Ebaugh.

By *his* Attorneys,

Baldwin, Hopkins & Peyton

D. C. EBAUGH.
Disintegrating or Mixing Machine.

No. 198,764.

Patented Jan. 1, 1878.

Fig 2.

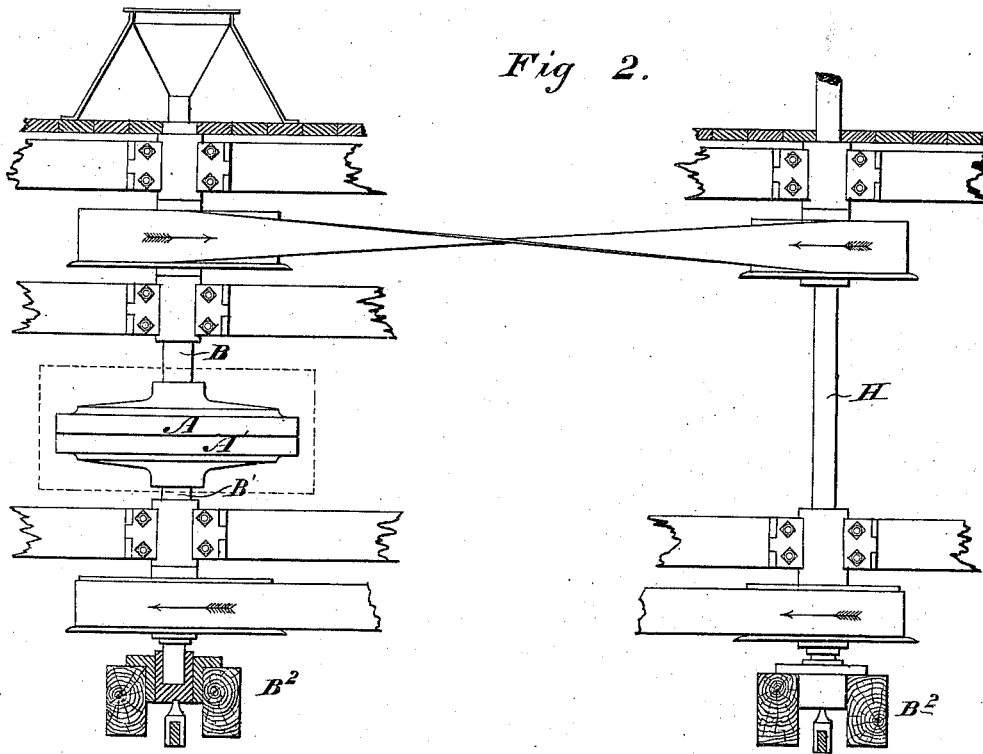

Fig 3

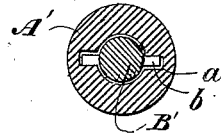

Fig 7

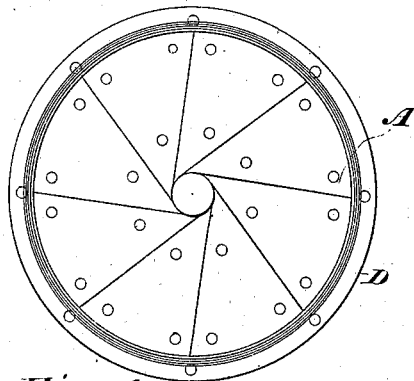
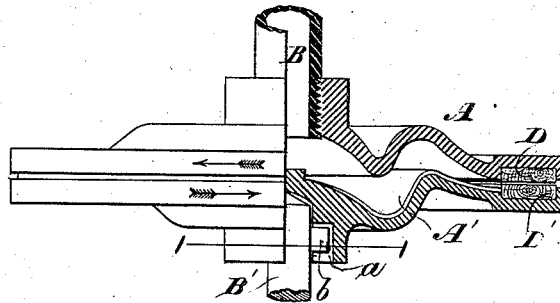
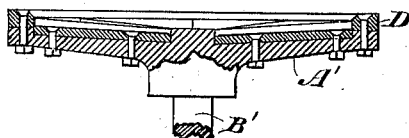

Fig 4.



WITNESSES

Wm A. Shinkley,
Geo W. Beck

INVENTOR

David C. Ebaugh.

By *his* Attorneys.

Baldwin, Hopkins & Peyton.

D. C. EBAUGH.
Disintegrating or Mixing Machine.

No. 198,764.

Patented Jan. 1, 1878.

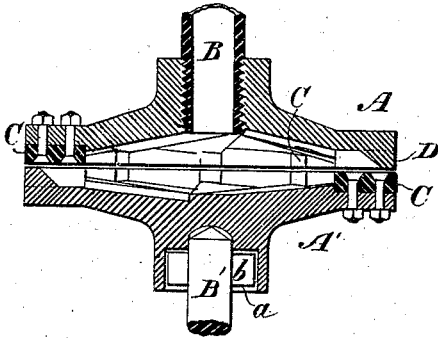

Fig 5.

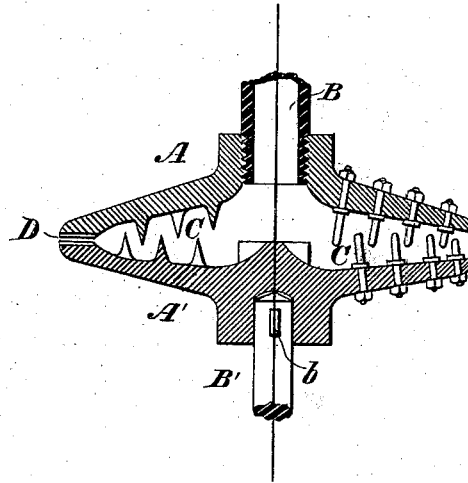
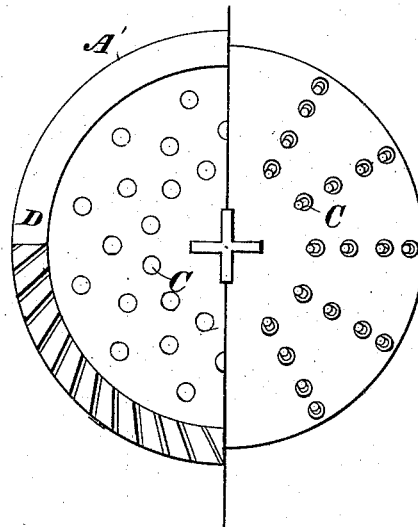
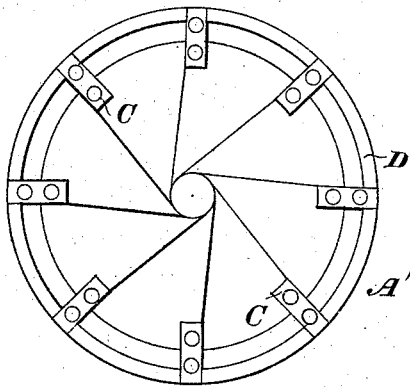

Fig 6.



WITNESSES

Wm. A. Skinkle
Geo. W. Brock

INVENTOR

David C. Ebaugh

By his Attorneys,

Robt. Hopkins & Peyton

UNITED STATES PATENT OFFICE.

DAVID C. EBAUGH, OF CHARLESTON, SOUTH CAROLINA.

IMPROVEMENT IN DISINTEGRATING OR MIXING MACHINES.

Specification forming part of Letters Patent No. **198,764**, dated January 1, 1878; application filed November 3, 1877.

To all whom it may concern:

Be it known that I, DAVID C. EBAUGH, of Charleston, in the State of South Carolina, have invented certain new and useful Improvements in Disintegrating or Mixing Machines, of which the following is a specification:

My invention relates to that class of mills which employ two horizontal runners, turning in opposite directions, between which the material is ground or reduced.

The object of my invention is to furnish a mill of the above character, in which the material will not alone be acted upon by the dressed faces of the runners, but will also be crushed by being forced one piece or part against another piece or part, and by direct percussion from a series of hammers, which new method of grinding, pulverizing, mixing, or disintegrating constitutes the prime feature of my invention.

To attain this end I construct the face of the runners of saucer shape or depressed form, and of such depth that the material may be fed to the runners in bulk, and not in a thin layer, as is ordinarily practiced, or, in other words, form a cavity between the runners, and provide the faces thereof with furrows and with hammers or projections, whereby the material, as it is fed to the rapidly and oppositely revolving runners, is thrown or carried by centrifugal force toward their peripheries, which are brought nearly together, or provided with raised rims, the material, in its passage, being ground or pulverized by the furrows or dress formed on the faces of the runners by the action of the material against itself, and, further, by direct percussion, owing to the action of the hammers or projections.

My invention further consists in providing the peripheries of the runners with raised rings or rims, of chilled iron or steel, to retain the material between the runners until it is ground or reduced sufficiently to pass through the opening or space left between them.

My invention further consists in the details of construction of the various parts of the apparatus, which will hereinafter specifically be described.

In the accompanying drawings, Figure 1 represents a view, in elevation, of the appa-

ratus and one method of driving it by gearing, the apparatus being partly in section, to more clearly show its construction. Fig. 2 is a similar view, the apparatus being shown as driven by belting. Fig. 3 is a sectional view of the lower driving-spindle and runner on the line 1 of Fig. 7, showing the manner of driving the poised runner by means of a key carried by the spindle; and Figs. 4, 5, 6, and 7 represent various forms of runners embodying my improvements.

The runners A A', which are preferably of metal, are supported horizontally upon vertical spindles B B', mounted in bearings in a suitable frame or timbers, and driven in opposite directions. The upper runner is rigidly secured upon the lower end of spindle B, face downward, while the lower one is poised upon the upper end of spindle B', face upward, being provided with a recess, for the reception of the end of the spindle, and with a slot, *a*, for the driving-key *b* carried by the spindle, whereby the two faces of the runners operate upon the material between them, and the lower runner, owing to its being poised upon its shaft, is free to balance and adjust itself when in motion.

The runners are provided with saucer-shaped or depressed faces, preferably deeper at the center, and growing shallower toward their peripheries, so that when brought together a cavity is formed between their working-surfaces, which allows material to be fed and operated upon in bulk, in contradistinction to those runners in which the operating-surfaces are close together, and in which only a thin layer of material can be operated upon by the grinding-surfaces.

The faces are dressed in well-known ways, or may be provided with false wearing-plates, having suitable furrows therein, or the plates may form furrows when secured in place, the cutting-edges of which may be chilled or hardened in usual well-known ways. The runners are also provided with a series of hammers or projections, C C, bolted, cast, or otherwise secured thereon, and with raised peripheral rims or rings D D, preferably of chilled iron or steel, provided with dressed faces.

These raised rims or rings retain the material between the runners until reduced sufficiently

fine to pass between the opening or space left between them; and as this space may be varied, so may the material which issues from it be varied as to fineness or size.

The foot of spindle B¹ is stepped in a lifting bridge-tree, B², of well-known construction, which permits of adjustment to compensate wear, and also of flexible adjustment to relieve the step of "dead" friction.

In Fig. 1, I have shown the respective spindles of the runners as driven in opposite directions by gearing consisting of bevel-wheels E E', mounted upon the spindles, which mesh with similar wheels F F', mounted on the ends of shafts G G', revolved by any suitable prime mover.

The lifting bridge-tree, in which is stepped the lower end of the spindle B¹, also carries one end of the shaft G', so that whenever the spindle B¹ is adjusted by the lifting bridge-tree the shaft G' follows its movement, owing to its journal-boxes being universal in a well-known way, whereby the gearing always continues in mesh; but any other mode of continuing the gearing in mesh may be employed.

The driving-spindle B is hollow, and leads directly to the cavity between the runners, by which means I am enabled to feed the material in bulk through a suitable "dead-eye" suspended directly over and passing through the hollow shaft.

In Fig. 2, I have shown a method of driving the apparatus by belting, which will be readily understood by an inspection of that figure; a lifting bridge-tree being shown both for the spindle of the lower runner and for the driving-shaft H.

In Fig. 4 the runners are shown as provided with false wearing-plates and raised rings or rims, the hammers being omitted.

In Fig. 5 the hammers are shown as set in the rims and projecting into the cavity, instead of being located entirely within the raised rims, as in Fig. 1.

In Fig. 6 the dress or furrows upon the faces of the runners is omitted, and spikes or projections formed thereon instead, which construction may be desirable in mixing certain articles, and for other purposes.

In Fig. 7, I have shown runners of an undulatory form, which increases the frictional surface, and is adapted for such purposes as cleaning or polishing materials, and cork or other soft substance may be inserted in the peripheries of the runners in lieu of the steel or hardened rims or rings.

Various other forms of runners will readily suggest themselves as peculiarly adapted for particular materials and purposes to those skilled in the art.

The operation of my improved apparatus is as follows: The material is fed through the hollow shaft to the cavity between the runners, which are rapidly revolved in opposite directions, and, falling upon the distributing-surface formed upon the center of the lower runner, is carried by centrifugal force, generated by the rotation of the runners, outward toward their peripheries. The material in its passage is acted upon by the dress or furrows, and, being in bulk, is forced one piece or part against another piece or part, which greatly aids in its reduction, and when it reaches the hammers or projections the reduction is still further effected by direct percussion. The material is retained between the runners by the raised rings or rims, which form, in reality, saucers of the runners, until reduced, ground, disintegrated, or mixed sufficiently fine to pass between the rims, the faces of which may also act upon the material before its final exit.

I claim as of my own invention—

1. The saucer-shaped runner, constructed substantially as hereinbefore set forth, having its concave face provided with a suitable dress or furrows, with a series of hammers, and with a raised ring or rim on its periphery.

2. The combination, substantially as hereinbefore set forth, of horizontal oppositely-revolving concave or saucer-shaped runners, having raised rims or flanges, and arranged with their concave faces opposite each other, whereby material may be fed in bulk between the runners, and disintegrated by the attrition of one particle upon another, and by the action of the runners, and retained between them until sufficiently reduced to pass between the rims.

3. In combination, saucer-shaped horizontal oppositely-revolving runners, having their concave faces opposite each other, and being provided with furrows, hammers, and raised rims, substantially as described, whereby the material fed to the runners is disintegrated by the attrition of one particle upon another, by the furrows and hammers, and retained by the rims until thoroughly pulverized.

4. The combination, substantially as hereinbefore set forth, of horizontal saucer-shaped oppositely-revolving runners, the hollow upper spindle through which the feed passes, the lower spindle stepped upon a bridge-tree, and the driving-gearing, for the purposes specified.

In testimony whereof I have hereunto subscribed my name.

D. C. EBAUGH.

Witnesses:

JAMES SIMMONS, Jr.,
E. C. HESSE.