

M. B. McMANUS  
Sand-Pump Reel.

No. 198,774.

Patented Jan. 1, 1878.

Fig. 1.

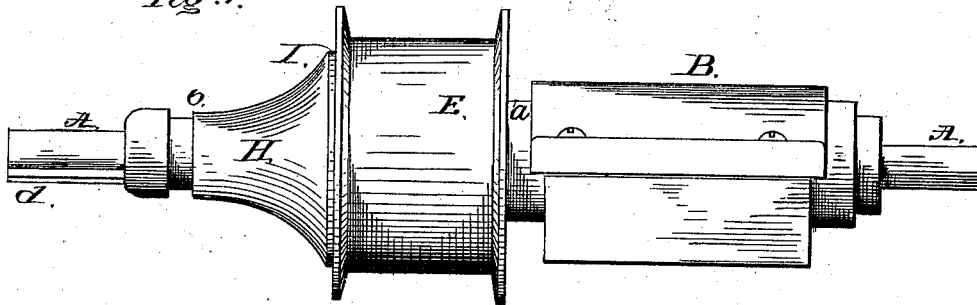

Fig. 2.

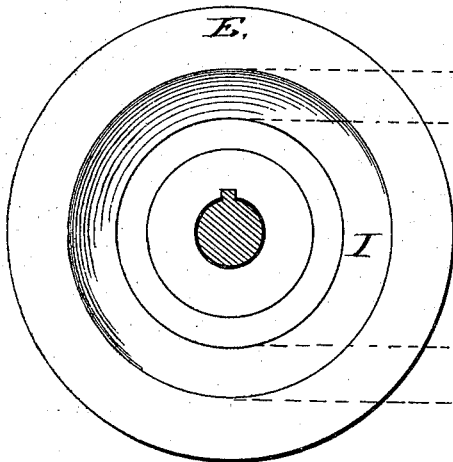

Fig. 3.

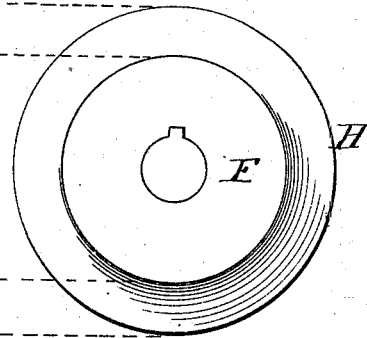
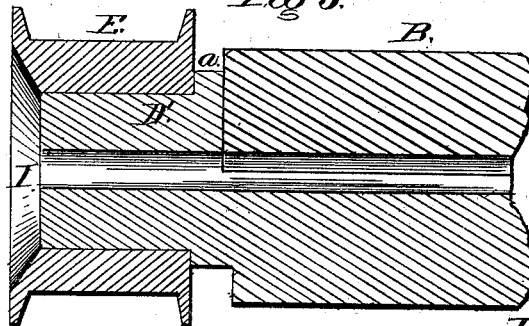

Fig. 4.



Fig. 5.



Witnesses;  
S. Walter Fowler  
Chas. Gill

Inventor;  
Michael B. McManus  
By his Atty  
Cox & Cox

# UNITED STATES PATENT OFFICE.

MICHAEL B. McMANUS, OF TITUSVILLE, PENNSYLVANIA.

## IMPROVEMENT IN SAND-PUMP REELS.

Specification forming part of Letters Patent No. **198,774**, dated January 1, 1878; application filed October 15, 1877.

*To all whom it may concern:*

Be it known that I, MICHAEL B. McMANUS, of Titusville, in the county of Crawford and State of Pennsylvania, have invented a new and useful Improvement in Sand-Pump Reels, of which the following is a specification, reference being had to the accompanying drawings.

The invention relates to an improvement in sand-pump reels; and consists in the devices hereinafter fully described.

The object of the invention is to furnish a reel in which the movement of the drum carrying the line is governed by a friction-clutch, thereby reducing the speed of the engine, removing the friction from the band-wheel, and facilitating the speed of sand-pumping.

Figure 1 is a side elevation of a device embodying the elements of the invention. Fig. 2 is a plan view of the socket I. Fig. 3 is a like view of clutch H. Fig. 4 is a side view of the shaft A; and Fig. 5 is a central vertical section, showing the drum in position.

In the accompanying drawings, A represents the main shaft, upon which is mounted the plumber-block B, having at its end the circular projecting stud D', provided with annular shoulder *a*, the stud D' being of sufficient dimensions to properly receive the drum E, one side of which is a plain surface, and impinges the shoulder *a*, while the central portions of the opposite side are removed, forming a socket, I, for admitting the end F of the clutch H, the other end of same being reduced and furnished with an annular groove, *b*, to assist in pressing the clutch to place in the socket I, for the purpose hereinafter mentioned.

The shaft A is supplied with the feather *d*, which enters a groove cut in the clutch H,

and serves as a guide for the same, at the same time causing the clutch to revolve with the shaft.

It is obvious that (the line of the sand-pump being wound upon the drum E, placed on stud D') when the clutch H is forced firmly into the socket I, the drum will be pressed against the shoulder *a*, and be thereby prevented from revolving; but if it is desired to lower the pumping apparatus into the well, it is simply necessary to withdraw the clutch H from the socket I, when the weight of the line, having a downward tension, will rotate the drum and unwind the rope.

The movement of the drum can be wholly or partially arrested at any time by simply moving the clutch back to its former position, the friction of the parts coming in contact preventing such rapid revolution.

To elevate the line and wind it upon the drum, the clutch is pressed into socket I, and the shaft A rotated in a contrary direction to that above mentioned, thereby reversing the movement of the drum and elevating the line and pump.

What I claim as my invention, and desire to secure by Letters Patent, is—

The feathered shaft A, provided with block B, having at its end the shoulder *a* and spline D', upon which the drum E is mounted, in combination with the clutch H, substantially as shown and described.

In testimony that I claim the foregoing improvement in sand-pump reels, as above described, I have hereunto set my hand this 26th day of September, 1877.

MICHAEL B. McMANUS.

Witnesses:

J. B. D. CLARK,  
CHAS. SHEPHERD.