

Z. BEAUDRY.
Burnisher-Head for Boot and Shoe Machines.

No. 198,835.

Patented Jan. 1, 1878.

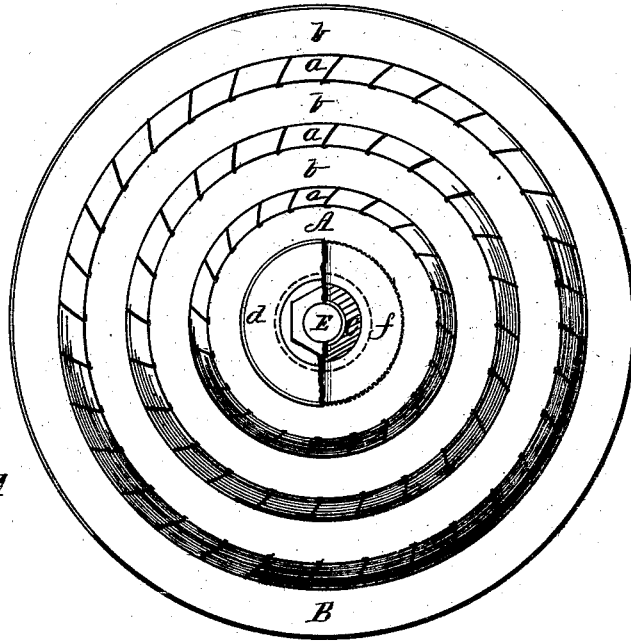

Fig. 1

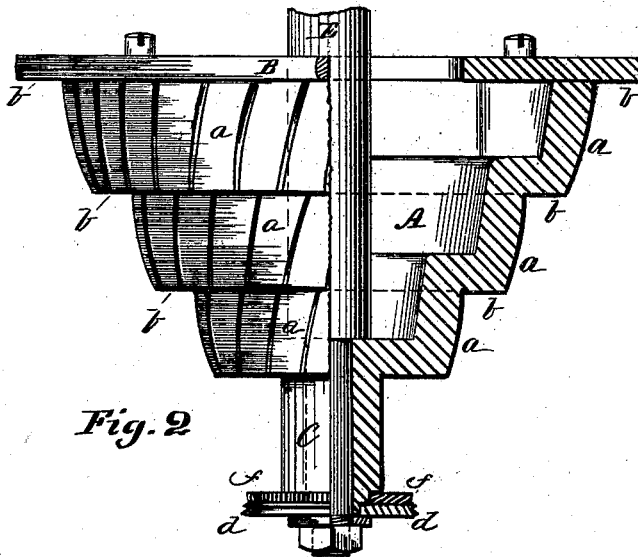

Fig. 2

Witnesses.

Geo. W. Ward
Hector Beaudry

Inventor

Zotique Beaudry
Per Charles Dmligh
Atty.

UNITED STATES PATENT OFFICE.

ZOTIQUE BEAUDRY, OF WORCESTER, MASSACHUSETTS.

IMPROVEMENT IN BURNISHER-HEADS FOR BOOT AND SHOE MACHINES.

Specification forming part of Letters Patent No. **198,835**, dated January 1, 1878; application filed November 28, 1877.

To all whom it may concern:

Be it known that I, ZOTIQUE BEAUDRY, of Worcester, in the county of Worcester and State of Massachusetts, have invented certain new and useful Improvements in Burnisher and Beading Heads for Boot and Shoe Machines; and I declare the following to be a description of my said invention sufficiently full, clear, and exact to enable others skilled in the art to which it appertains to make and use the same, reference being had to the accompanying drawings, which form a part of this specification, and in which—

Figure 1 represents a front view of my improved burnisher-head, a portion being shown broken away to reveal parts beneath; and Fig. 2 represents a half-side, half-sectional view of the same.

One feature of my invention consists in the peculiar construction of the head with a series of burnishing-surfaces and guard-flanges, arranged as shown.

A second feature consists in a burr-beader, arranged to operate in the manner hereinafter set forth.

A third feature consists in the burnisher-head having a central projection and welt-beading tool, as hereinafter described.

My improved burnisher-head consists of a hollow conical body, A, made from metal in the form shown, and having a series of burnishing-surfaces, *a*, of different widths and sizes about its periphery, the contour of said surfaces being such as will correspond with the curvature of heel-edges desired for the several sizes or kinds of boots or shoes. At the rear edges of the burnishing-surfaces *a* annular guard-flanges or offsets *b* are formed, against which to place the bottom of the boot-heel, for guiding and supporting it in proper position while burnishing the edge. The planes of the flange-faces *b* are perpendicular to the axis of revolution, while the inclination of the burnishing-surfaces is such that the angle between the surfaces *a* and *b*, at any radial position, equals the angle required for the lower corner of the heels. The bottom of the heel being pressed against the surface *b*, while the edge is pressed against the surface *a*, confines the leather, so as to give a firm and solid

corner on the heel, and preserves the bottom surface of the heel flat and even.

The extreme rear flange *b* may be formed on an annular plate, B, screwed to the body A, in order to facilitate the casting of the conical body; or, if preferred, the parts may be of a single piece.

A spindle or sleeve, C, projects from the central front part of the head A, upon the end of which is an annular beading-tool, *d*. Said tool *d* is secured to revolve with the head A, and has a welt-bead formed upon its periphery, as indicated. A burr-beader, *f*, having a milled or otherwise ornamented edge, is arranged adjacent to the bead *d*, which turns loosely upon the spindle or sleeve C, whereby, when the bead *d* is worked upon the heel-welt, the burr-beader *f* will roll upon and imprint its ornamental figure upon the exterior edge surface of the heel by one and the same movement.

The sleeve C is made of sufficient length, and the beaders *f* *d* of sufficient diameter, to permit of the beads being worked without the boot or shoe interfering or striking the burnishing portion of the head.

For operation, the head A is mounted upon a suitable revolving shaft, E, which may be the shaft or spindle of any boot and shoe burnishing machinery.

The boots or shoes may be supported by a suitable jack device, or pressed by hand against the burnishing-surfaces of the head. The bottom of the heel, being pressed against the flange *b*, not only guides the position of the boot, but also prevents the corner of the heel from being upset or battered over by the burnishing-tool, thus leaving the bottom of the heels square and flat.

The head may be heated by a gas-flame inside the conical part A, if desired.

The burnishing-surfaces are preferably made with grooves or corrugations, as indicated.

The wax used for the edges can be applied to the corrugated surfaces of the head.

The head may be made with but one of the beaders *d* or *f* when desired.

With this head work can be very rapidly performed, and no change of head is required for various thicknesses of heels, while the bead-

ing can be done without the necessity of the boot or shoe changing hands.

Having described my improvements in burnisher-heads, what I claim as new and of my invention, and desire to secure by Letters Patent, is—

1. The burnisher-head A, constructed, as hereinbefore described, with the series of burnishing-surfaces *a* and guard-flanges *b*, arranged for supporting the bottom of the heels with their face-planes perpendicular to the axis of revolution, substantially as shown, and for the purpose set forth.

2. A revolving burnisher-head carrying an ornamental burr-beader, *f*, supported to revolve about the same axis, and arranged for independent rotary movement, substantially as set forth, whereby said bead can be rolled upon the heel-surface, for the purpose stated.

3. The combination, with the revolving annular welt-bead *d*, of the burr-bead *f*, arranged adjacent thereto upon the same spindle or axis, but free to revolve independently, substantially as and for the purpose set forth.

4. The revolving burnisher and beading head, made with the series of burnishing-surfaces *a*, guard-flanges *b*, central projection or sleeve C, and annular welt-beader *d*, substantially as and for the purposes set forth.

Witness my hand this 22d day of November, A. D. 1877.

ZOTIQUE BEAUDRY.

Witnesses:

CHAS. H. BURLEIGH,
NECTAIRE BEAUDRY.