

G. W. THOMPSON.
Gas-Regulator.

No. 198,862.

Patented Jan. 1, 1878.

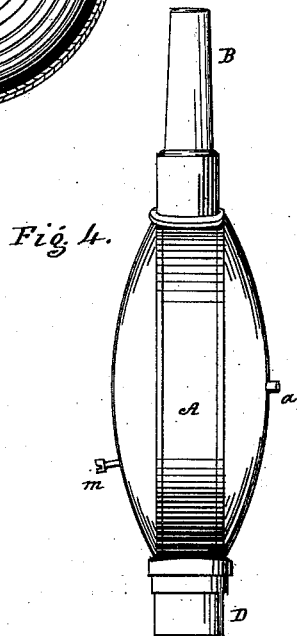
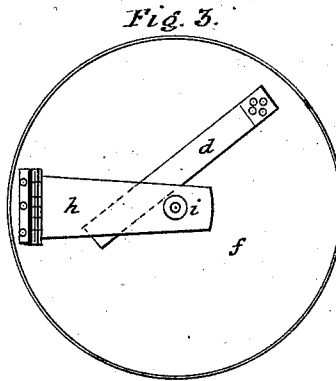
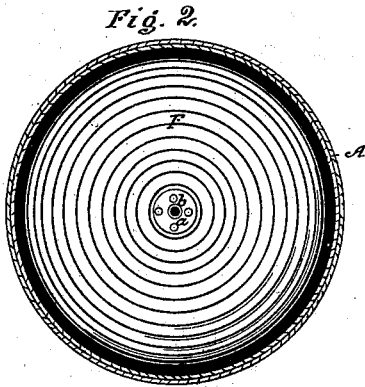
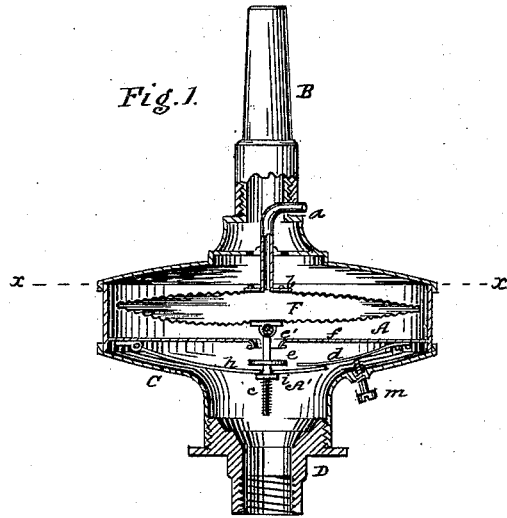

Witnesses:
Chas. H. Friend
Thomas Whaley

Inventor:
George W. Thompson,
By his atty.
John S. Thornton

UNITED STATES PATENT OFFICE.

GEORGE W. THOMPSON, OF BROOKLYN, ASSIGNOR OF ONE-FOURTH HIS
RIGHT TO JACOB COHEN, OF NEW YORK, N. Y.

IMPROVEMENT IN GAS-REGULATORS.

Specification forming part of Letters Patent No. **198,862**, dated January 1, 1878; application filed
October 15, 1877.

To all whom it may concern:

Be it known that I, GEORGE W. THOMPSON, of the city of Brooklyn, in the county of Kings and State of New York, have invented an Improved Gas-Controller, of which the following is a full, clear, and exact description, reference being had to the accompanying drawings, forming a part of this specification.

My invention relates to an improved gas-controller or gas-regulator, to be used at or near the burner or point of combustion, for regulating the pressure and consumption of the gas, and preventing waste thereof; and its object is to construct the same in such a manner that it will be very durable, will not be liable to get out of order, may be easily adjusted, and will at all times insure an equable consumption of gas under varying pressures.

My said invention consists, principally, in a flexible, elastic, metallic box, composed of two disks of thin corrugated sheet metal, connected at their peripheries, which I inclose within a chamber that connects with the supply-pipe and the burner-tip, which said box is compressed by every increase of pressure, and is expanded when the pressure is removed or diminished, and, by such compression and expansion, operates a valve or other suitable device for regulating the influx of gas.

It also consists in the improved constructions and combinations of the several parts, as hereinafter particularly described.

In the accompanying drawings, Figure 1 represents a vertical section of my improved gas-controller, taken through its center; Fig. 2, a horizontal section on the line *x x*; Fig. 3, a plan view of the under side of the chamber, the lower cover being removed; and Fig. 4, a modification of my said invention, showing a different arrangement.

Similar letters of reference indicate the same parts in the several figures.

A is a chamber, of any convenient form and dimensions, within which the flexible box above mentioned is inclosed, and which is connected with and supports the burner-tip B, which latter may be of any of the ordinary kinds. C is a case or cover, which fits on the under side of the chamber, forming a second

chamber, A', and being attached to the supply-pipe by any suitable connection, D.

F is my improved box or device for regulating and controlling the pressure and consumption of gas at the point of combustion. It consists of two disks of thin corrugated sheet metal or other suitable material which is sufficiently flexible and elastic, and will resist the heat of the flame, which said disks are attached together at their periphery by an air-tight joint. It is suspended in the chamber A from the end of a small pipe, *a*, which forms a communication between the box and the outer atmosphere by means of a flange or plate, *b*, riveted to the upper disk. By means of this pipe air is freely admitted into the interior of the said box F when the box is expanded, and is expelled from the same, when the box is compressed, by the pressure of the gas in the chamber A.

c is a rod pivoted to a plate attached to the lower disk, which carries a disk or valve-plug, *e*, that fits to a valve-seat, *e'*, formed in the partition-plate *f*.

The box F is expanded by means of a spring, *d*, secured to the plate *f*, which bears upon a hinged rod or plate, *h*, which is perforated to receive the end of the rod *c*; and the extent to which the said box is to be expanded is regulated by means of a screw-nut, *i*, on the said rod *c*.

The force or pressure of the spring *d*, and, consequently, the degree of pressure required to compress the box F, is regulated by means of an adjusting-screw, *m*, which passes through the lower case, and is adjusted from the outside.

The gas passes through the two chambers on its way from the supply-pipe to the tip, and the nut *i* and spring *d* having been adjusted to the desired degree of supply and pressure, whenever the pressure on the gas is increased, the increased pressure within the chamber A compresses the box F, and closes or partially closes the valve, thereby diminishing the supply into the chamber A, and maintaining an equable supply and pressure at the point of combustion.

I may state that the means employed for expanding the box, and also for regulating

the supply and the degree of pressure required to compress the box, may be modified or varied without departing from the principle of my invention—as, for instance, a spring inside the box, or a weight suspended from the lower disk, may be employed to expand the same, and other equivalent devices may be employed for adjustment to the desired degree of pressure.

I may also state that my invention may be applied to other kinds of apparatus in which it is desired to regulate the supply of gases or fluids under pressure, so as to diminish the supply under increased pressure, or vice versa, as well as to gas-burners.

The supply-pipe, tip, and controller may be arranged as shown in Fig. 4, if preferred.

What I claim as my invention is—

1. The flexible and elastic box F, into which the outer air is freely admitted, suspended within a chamber, A, substantially as set forth, for the purpose of operating a valve by the pressure of the gas in the said chamber, and

thereby to diminish or increase the supply of gas.

2. The box F and pipe *a*, in combination with the chamber A, and suitable devices for diminishing the supply of gas to the said chamber, in proportion to the degree of pressure of the gas within the said chamber.

3. The combination of the box F, chamber A, valve *e e'*, and screw-nut *i* on the rod *c*, as and for the purpose set forth.

4. The combination of the box F, chamber A, valve *e e'*, and adjustable spring *d*, as and for the purpose set forth.

5. The gas-controller herein described, consisting of the chamber A, box F, adjustable valve *e e'*, and adjustable spring *d*, arranged in relation to the burner-tip and supply-pipe, substantially as herein shown and described.

GEO. W. THOMPSON.

Witnesses:

JOHN S. THORNTON,
THOMAS WHALEY.