

B. ROWELL.
Car-Coupling.

No. 198,903.

Patented Jan. 1, 1878.

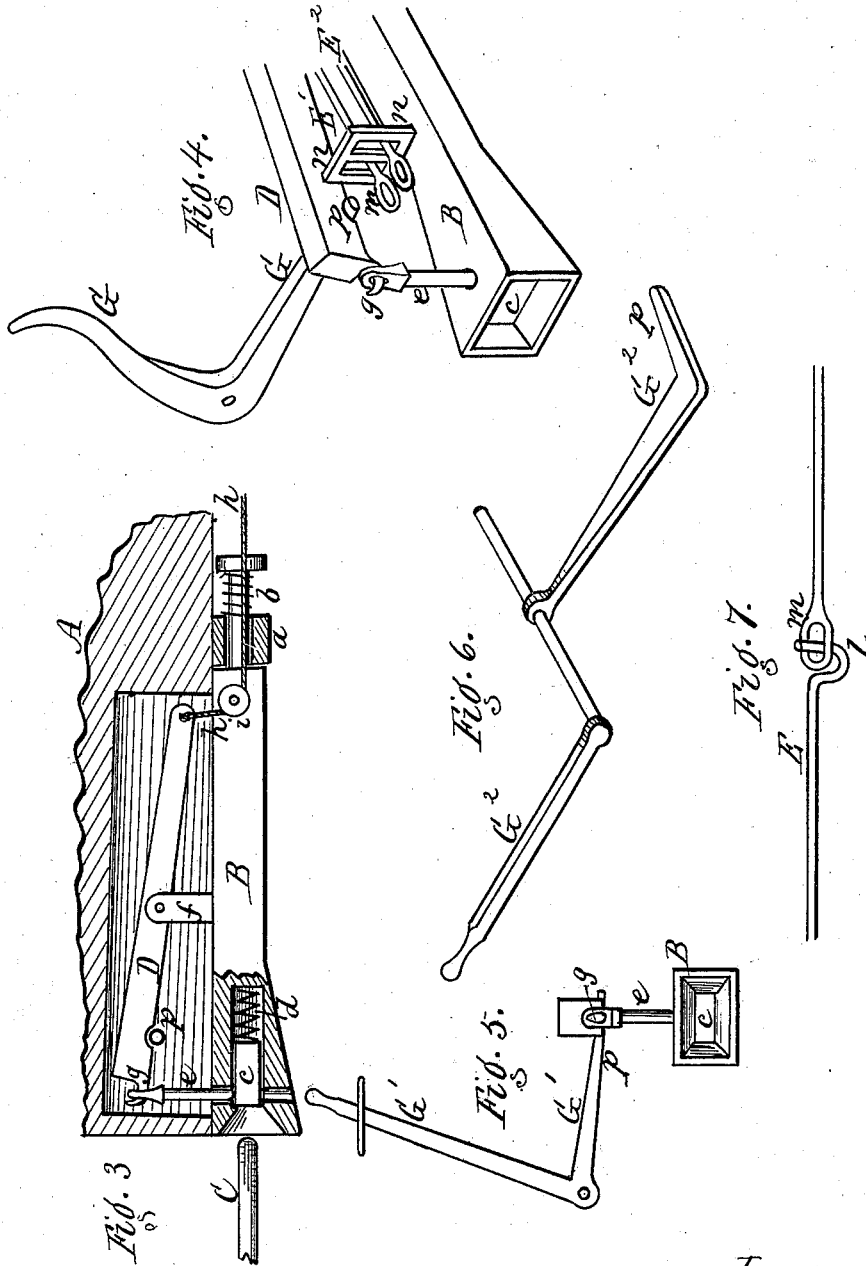

Attest.
Jacob Spahr
A. E. White

Inventor:
Benning Rowell,
per R. L. Osgood,
Atty.

UNITED STATES PATENT OFFICE.

BENNING ROWELL, OF WEST SPARTA, NEW YORK.

IMPROVEMENT IN CAR-COUPLINGS.

Specification forming part of Letters Patent No. **198,903**, dated January 1, 1878; application filed December 7, 1877.

To all whom it may concern:

Be it known that I, BENNING ROWELL, of West Sparta, in the county of Livingston and State of New York, have invented a certain new and useful Improvement in Car Couplers and Uncouplers; and I do hereby declare that the following is a full, clear, and exact description of the construction and operation of the same, reference being had to the accompanying drawings, in which—

Figure 1 is a bottom view of several cars connected by my improved coupling. Fig. 2 is a side elevation of the same. Figs. 3, 4, 5, 6, and 7 are detail views.

My improvement relates to an arrangement for coupling and uncoupling railroad-cars, so constructed as to be self-coupling, and to be uncoupled either by the brakemen at their ordinary positions in the train, or by the engineer or fireman at the front, who can uncouple any car from front to rear, as may be desired.

The invention consists in the construction and arrangement of parts hereinafter more fully described and definitely claimed.

A A A represent three cars in a train, which are of ordinary construction, the drawing, for the purpose of illustration, showing a freight, a passenger, and a flat car, all coupled together by my improved arrangement. B B B are the draw-heads, secured to the frame-work of the cars, being held by boxes or straps *a a*, and having springs *b b* at their rear ends, as usual, to break the concussion, and to react in starting. C C C are ordinary links or shackles, which enter the mouths of the draw-heads in the usual manner. *c c* are sliding blocks in the outer ends of the draw-heads, which are held forward by coiled springs *d d*, and, when the cars are uncoupled, hold up the coupling-pins *e e*, which rest on top the blocks, as shown in Fig. 3. *f f* are bearings or fulcrums on top the draw-heads, and within the frame-work of the cars. D D are rock-levers pivoted to said bearings. The outer ends of these rock-levers have hooks *g g*, which pass through holes in the upper end of the coupling-pins, thereby holding the pins up, while the rear ends of the levers have holes, or are otherwise arranged to receive the draw cords or chains by which the couplings are

uncoupled. *h h* are the draw cords or chains attached to the rock-levers, and *i i* are grooved pulleys in the rear end of the draw-heads, around which the cords pass, as shown in Fig. 3. When the cords are drawn, it will be seen that the rear ends of the rock-levers will be depressed, and the coupling-pins will be raised from their sockets when coupled, and in such case the blocks *c c* will spring under the coupling-pins and hold them elevated, as described.

E E' are rods under the cars, resting loosely in eyes or bearings *j j*, so as to have a free end movement. At the outer end of the car next the engine they are attached to levers F F', which extend up within easy reach of the operator on the engine or tender. As the levers are thrown the rods will be drawn back endwise, and the reaction of the rods to resume their original position is caused by coiled springs *k k*, Fig. 1, resting around them.

There are as many of these rods and levers as there are cars in the train, less one car—namely, the rear one. The first rod, E, is connected with the cord *h*, which operates the coupling between the first and second cars. The rod E' is connected with the cord which operates the coupling between the second and third cars, and so on, according to the number of cars in the train, and the number of rods to correspond with the same.

All the rods, except the first, are jointed at the couplings between the cars, being thus made in sections, and these sections are at the couplings, and these sections have, respectively, one a hook, *l*, and the other an eye, *m*, the eye dropping into the hook when the coupling is engaged, thus making a continuous length, as shown in Fig. 7. The eye ends of the sections rest in loops *n*, and these loops are attached as a fixture to the side of the rock-levers D D, so that as the latter are raised to uncouple the pin from the link the eyes will also be raised to uncouple from the hooks, leaving the connections between the cars entirely free. Where a greater number than three cars are in a train, the loops *n* are formed with divisions or separate bearings for the several rods, as shown in Fig. 4.

By the means above described it is manifest that the engineer or fireman, by operating any one of the rods E E', can uncouple at any point

between the front and rear of the train, or detach any car he pleases, which is a very great convenience under many circumstances—for instance, in case of accident, or in switching off, or in making up a train.

G G¹ G² are levers for the use of brakemen in uncoupling. They are located at proper position at the ends or sides of the cars. They are pivoted in place, and have ends or projections *p*, which rest under the rock-levers D D, as shown in Fig. 4, and, when thrown, they raise the coupling-pins and eyes of the rods to uncouple, as before described. G in Fig. 4 shows the lever connected with the end or platform of a passenger-car. G¹, Fig. 5, shows a lever for a freight-car, the same extending to the top of the car. G², Fig. 6, shows a lever for a flat-car, the same passing through the side of the car and operated at the side. These levers may be arranged in any desired way, the ends resting under the rock-levers D only, so as not to interfere with the uncoupling from the front of the train.

Having thus described my invention, I claim—

1. The combination, with the couplings of a railway-train, of the rods E E', connected with the devices for raising the coupling-pin to uncouple, the rods succeeding the first rod being made in sections, provided with hook-and-eye joints coinciding with the couplings, and the eye ends being connected with the devices for raising the coupling-pin, whereby the operator, standing at the front, can uncouple the coupling and disconnect the sections of the rods at one and the same action, and can uncouple or detach any car in the train at will, as herein described.

2. The combination, with the spring-slide *c*

and the coupling-pin *e* resting thereon, of the cord *h*, connecting with the devices for raising the pin, and the rod E, to which the cord is attached, extending to the front of the train, as shown and described, and for the purpose specified.

3. The combination, with the coupling of a railway-train, of the rod E, the cord *h*, the pulley *i*, and the rock-lever D, provided with a hook or equivalent device at its end, for holding the coupling-pin, as shown and described, and for the purpose specified.

4. In a car coupler and uncoupler, the rod E', constructed in sections, with hook-and-eye joints coinciding with the couplings, the eye-section being connected with the devices for raising the coupling-pin, in such a manner that the coupling-pin and the eye are raised at one and the same action, as herein described.

5. In combination with the rock-lever D, having the coupling-pin *e* suspended so as to be raised and lowered with it, the bearing or loop *n*, attached to the rock-lever and holding the rod or rods E, the whole arranged as described, so that the coupling-pin and the rod receive a simultaneous motion when the rock-lever is operated, as herein described.

6. The combination, with the rock-lever D, having the suspended coupling-pin *e* and the loop *n*, of the pivoted lever G, having its end resting loosely under the rock-lever, as shown and described, and for the purpose specified.

In witness whereof I have hereunto signed my name in the presence of two subscribing witnesses.

BENNING ROWELL.

Witnesses:

R. F. OSGOOD,
LOWELL M. HOYT.