

T. K. KEITH.
Feeding-Mechanism for Sewing-Machines.

No. 198,915.

Patented Jan. 1, 1878.

Fig. 1.

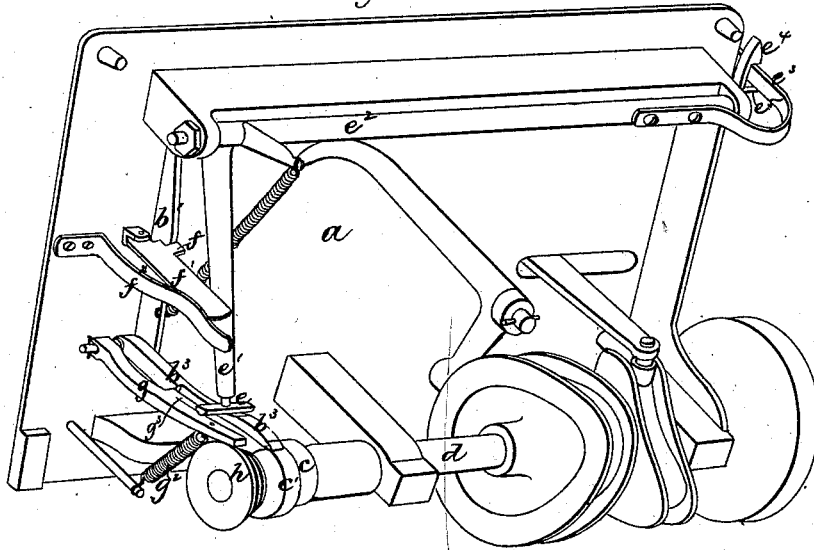

Fig. 2.

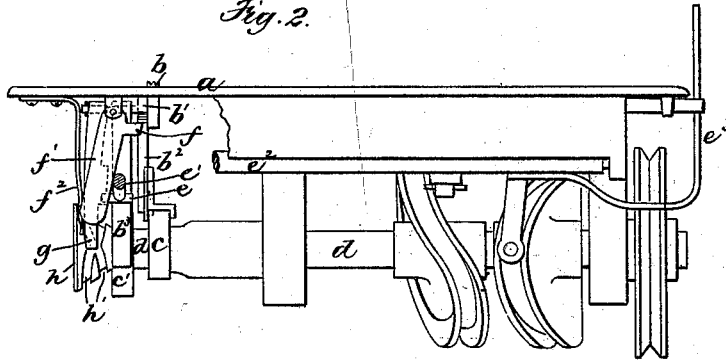

Fig. 3.

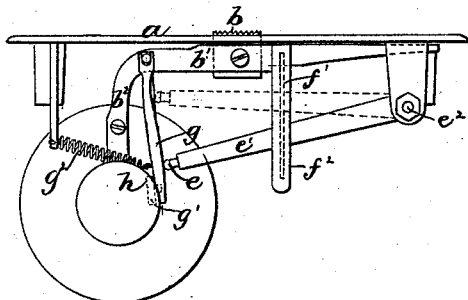

Fig. 4.

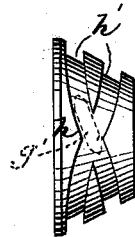
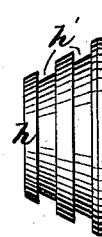

Fig. 5.



Witnesses.
J. C. Main
Wm. S. B. Maine.

Inventor.
T. K. Keith
By Wright & Brown.
Atty

UNITED STATES PATENT OFFICE.

THOMAS K. KEITH, OF HAVERHILL, MASSACHUSETTS, ASSIGNOR TO MOSES HOW, OF SAME PLACE.

IMPROVEMENT IN FEEDING MECHANISMS FOR SEWING-MACHINES.

Specification forming part of Letters Patent No. **198,915**, dated January 1, 1878; application filed October 23, 1877.

To all whom it may concern:

Be it known that I, THOMAS K. KEITH, of Haverhill, in the county of Essex and State of Massachusetts, have invented certain Improvements in Sewing-Machines, of which the following is a specification:

In the accompanying drawings, forming a part of this specification, Figure 1 represents a perspective view, showing the under side of a Howe machine provided with my improvements. Fig. 2 represents a side view of the same with a portion of the bed of the machine and the rock-shaft removed. Fig. 3 represents an end view of the same. Figs. 4 and 5 represent views of the conoidal grooved disk.

Similar letters of reference refer to like parts in all the figures.

This invention is an improvement on a prior invention of mine for which Letters Patent were issued to me October 9, 1877, said patented invention consisting in the combination, with the stitch-forming mechanism of a sewing-machine, of a feed-dog adapted to reciprocate the work or material being stitched in a horizontal plane, instead of propelling it in a single direction, and thus cause the stitch-forming mechanism to produce a series of elongated stitches, which the operator could combine in various ornamental designs by turning the work laterally during the operation.

The present invention has for its object to enable an ordinary four-motioned feed-dog, adapted to propel the work in a single direction, as usual, to be converted into a two-motioned horizontally-reciprocating feed-dog, adapted to reciprocate the work instead of propelling it in a single direction, so that one and the same feed-dog can be employed in forming the elongated stitches above referred to, as well as in forming the ordinary continuous lines of stitches.

To this end my invention consists in the provision of means whereby an ordinary four-motioned feed can be converted at the will of the operator into a two-motioned feed, reciprocating in a substantially horizontal plane, so as to reciprocate the work instead of propelling it in one direction, as I will now proceed to describe.

In the drawing, *a* represents the bed of a

sewing-machine, provided with a four-motioned feed-dog, *b*, attached to a bar, *b*¹, which is of the class that is provided with a rigid arm, *b*², which bears upon the upper portion of a periphery of a cam, *c*, on the driving-shaft *d*, and receives a vertical motion from said cam and a pivoted lever, *b*³, which bears against the side of a cam, *c*, on the driving-shaft, and is provided with a vertically-adjustable fulcrum, *e*, the cam *c* and fulcrum *e* giving the bar *b*¹ its horizontal motion. The fulcrum *e* is located on the end of an arm, *e*¹, which projects from a rock-shaft, *e*², the latter being journaled in bearings in the bed *a*, and capable of being rocked, so as to raise and lower the fulcrum *e*, and thus vary the horizontal movement of the feed-bar.

The parts thus far described in themselves are not my invention, as they constitute a common four-motioned feed mechanism adapted to propel the work in a single direction only, as usual.

To convert the feed-dog into a two-motioned or horizontally-reciprocating feed, adapted to reciprocate the work instead of propelling it in a single direction, I employ the means which I will now describe.

f represents a vertically-adjustable rest, which is adapted to raise and support the bar *b*¹ of the feed-dog at the highest point to which the feed-dog rises when operating as a four-motioned feed, and, while allowing the feed-dog to reciprocate horizontally, prevents it from rising and falling while in its raised position. The rest *f* is a projection formed on a lever, *f*¹, which is pivoted to the under side of the bed *a*, and depends therefrom in an inclined position, and is held with a yielding pressure against the arm *e*¹ of the rock-shaft by a spring, *f*².

g represents a lever, which is pivoted to the feed-bar *b*¹ by the side of the lever *b*³, and is adapted to oscillate and bear against the fulcrum *e* in like manner as the lever *b*³, and is adapted, as hereinafter described, to reciprocate the feed-dog horizontally when the latter is supported in its raised position by the rest *f*.

h represents a conoidal or tapering disk rigidly attached to the end of the driving-shaft *d*, and provided in its periphery with a cir-

cumferential endless groove, h' , which extends twice around the disk and intersects itself at one point, as shown in Fig. 4, the parts of the groove being substantially parallel with each other, excepting where they intersect, as shown in Fig. 5. The conoidal form of the disk h gives the groove a varying diameter, the part nearest the base or larger end of the disk being of a larger diameter than the part nearest the smaller end.

The lever g has a lug, g^1 , pivoted to its lower end, and this lug is adapted to engage with the groove h' at one side of the disk in such manner as to follow the groove as the disk revolves, the lug being alternately in the outer and inner portions of the groove, and the lever g being adapted to rock or oscillate laterally to a sufficient extent to enable its lug to follow the line of the groove. A spring, g^2 , holds the lug g^1 in the groove with a yielding pressure.

It will be seen that when the lug g^1 is in the outer portion of the groove h' the lower end of the lever will be farther from the axis of the disk h than when the lug is in the inner portion of the groove. Therefore the passage of the lug from one part of the groove to the other causes the lever to swing in and out from the axis of the disk h , and when the fulcrum e is in contact with the lever g , as hereinafter described, this motion of the lever will reciprocate the feed-dog.

When the sewing-machine is arranged for doing ordinary work, the feed-dog propelling the work in a single direction, the fulcrum e is raised, as shown in dotted lines in Fig. 3, the lever g and disk h being so arranged that when the fulcrum is in this position it will not bear against the lever g ; hence the latter is inoperative. At the same time the arm e^1 holds the lever f^1 in such position that the rest f is depressed, and does not support the feed-bar b^1 ; hence the feed-dog is operated solely by the cams c c' , arm b^2 , and lever b^3 , whereby a four-part motion is given it, as usual.

When it is desired to form the elongated ornamental stitches before referred to, the operator turns the work-shaft e^2 so as to lower the arm e^1 and fulcrum e . The motion of the arm e^1 allows the lever f^1 to be turned on its pivot by the spring f^2 , so as to raise the rest f and cause the latter to raise the bar b^1 and feed-dog b to the highest point reached by the latter in feeding the work, the spring f^2 being sufficiently strong to prevent the feed-dog from falling while in this position, so that the rest constitutes a support upon which the bar b^1 can reciprocate horizontally without rising and falling.

The depression of the fulcrum e causes it to

bear against the lever g , so that, as the latter is oscillated or swung toward and from the axis of the disk h by the grooved disk, as described, the fulcrum will cause the oscillation of the lever g to reciprocate the feed-bar b^1 and dog b , as will be readily seen. Thus the feed-dog is converted by a single movement of the rock-shaft from a four-motioned to a two-motioned feed, and vice versa.

I prefer to provide the rock-shaft e^2 with a lever, e^3 , whereby it may be turned, this lever working between two stops or catches, e^4 e^5 , whereby the rotation of the rock-shaft is limited.

My improvements can be applied to a sewing-machine in a short time and at small cost. In the machine represented the fulcrum e is elongated, so that it will serve for the levers g and b^3 , and the lever g is provided with an offset, g^3 , on the side next the lever b^3 , this offset forming a bearing for the fulcrum when the lever g is engaged with the outer portion of the groove h' , and, therefore, moved somewhat away from the lever b^3 .

I claim as my invention—

1. In a sewing-machine, a feed-dog adapted, when in its normal condition, to propel the work in a single direction, combined with mechanism, substantially as described, for raising and supporting said feed-dog and preventing it from rising and falling, and mechanism for reciprocating it in a substantially horizontal plane, whereby, when the said feed-dog is raised and reciprocated, it reciprocates the work instead of propelling it in a single direction, substantially as and for the purpose specified.

2. In combination with the feed-dog b , the adjustable rest f , adapted to support said feed-dog in a raised position, and mechanism, substantially as described, for raising and lowering said rest, as and for the purpose specified.

3. In combination, the oscillating lever g , the feed-dog b and bar b^1 , the conoidal grooved disk h , the pivoted rest f , provided with spring f^2 , the fulcrum e , the arm e^1 , and the rock-shaft e^2 , substantially as described.

4. In combination with the conoidal disk h , having the intersecting endless grooves h' , and the lever g , adapted to oscillate in two directions, and provided with the pivoted lug g^1 , the spring g^2 , substantially as and for the purpose specified.

In testimony whereof I have signed my name to this specification in the presence of two subscribing witnesses.

THOMAS K. KEITH.

Witnesses:

CHARLES M. HOW,
C. F. BROWN.