

J. HAY.
Automatic Fans.

No. 198,938.

Patented Jan. 8, 1878.

Fig. 1.

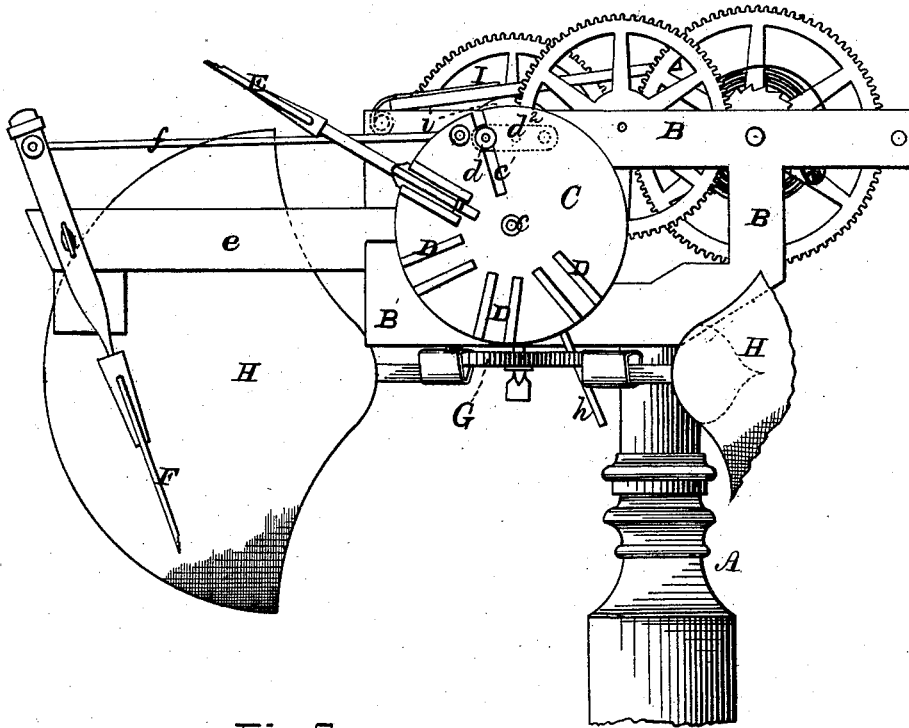

Fig. 2.

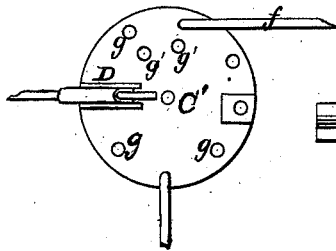
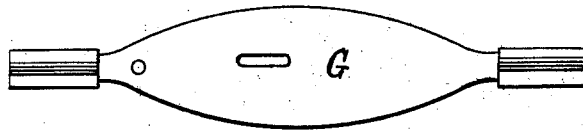

Fig. 3.



WITNESSES-

Jaas. Hutchinson.
D. W. Miller.

INVENTOR,
John Hay
Edson Bros.
Attorney

J. HAY.
Automatic Fans.

No. 198,938.

Patented Jan. 8, 1878.

Fig. 4.

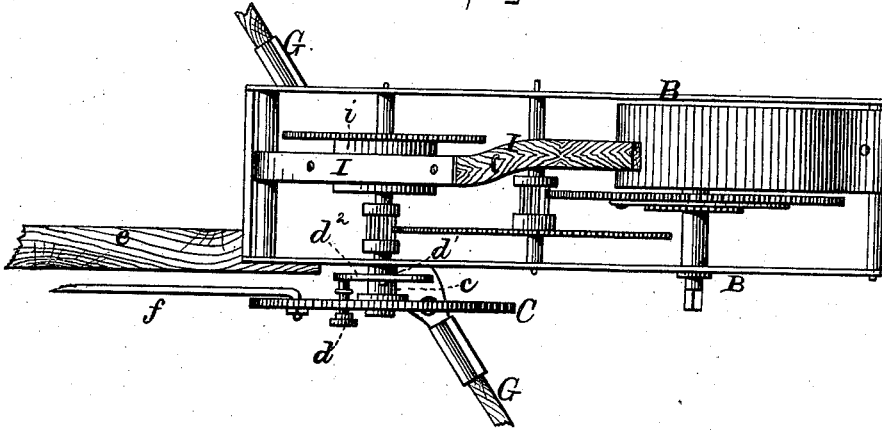
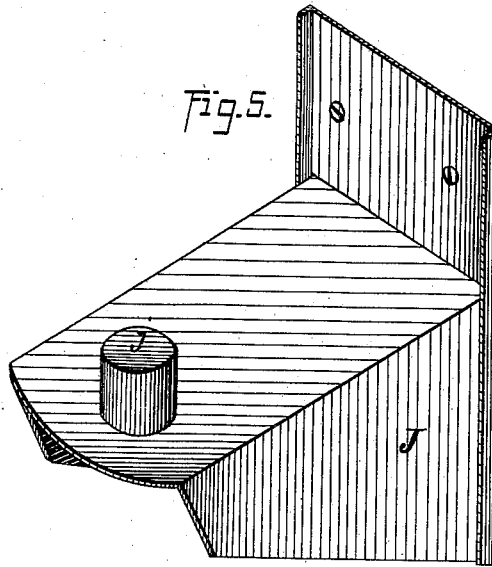

Fig. 5.



WITNESSES-

Geo. E. Hutchinson
Wm. Miller

INVENTOR-

John Hay
Edson Bros.
Attorneys

UNITED STATES PATENT OFFICE.

JOHN HAY, OF JUNCTION CITY, KANSAS.

IMPROVEMENT IN AUTOMATIC FANS.

Specification forming part of Letters Patent No. **198,938**, dated January 8, 1878; application filed May 24, 1877.

To all whom it may concern:

Be it known that I, JOHN HAY, of Junction City, in the county of Davis and State of Kansas, have invented certain new and useful Improvements in Fans; and I do hereby declare that the following is a full, clear, and exact description thereof, which will enable others skilled in the art to which it appertains to make and use the same, reference being had to the accompanying drawings, and to letters of reference marked thereon, which form a part of this specification, and in which—

Figure 1, Sheet 1, is a side view of my improved fan. Fig. 2 is a side view of another vibrating disk which operates one of the fans. Fig. 3 is a plan view of the lever to which the horizontally-vibrating fans are attached. Fig. 4, Sheet 2, is a plan view of the fan, and Fig. 5 is a detached perspective view of a portable bracket or support for the fan.

Corresponding parts in the several figures are denoted by like letters.

This invention relates to a certain improvement in fans; and it consists of mechanism by which the fans may be operated in divers directions, their angle of presentation and stroke being varied, and a greater or less current of air being obtained, substantially as hereinafter more fully set forth.

In the annexed drawing, A refers to an upright or support, upon which is mounted a frame, B, which may be susceptible of horizontal rotation. This frame is provided with internal mechanism for automatically operating the fan or fans.

C is a disk or plate, having its axis *c* fastened to the frame B. The plate or disk C is provided with a slot, *c'*, which receives an arm, *d*, of a crank-shaft, *d' d''*, extending from the operating mechanism, through which motion—a vibratory one—is imparted to the disk C. The lever or bar *d''* having apertures to change its point of attachment to the shaft *d'*, so as to increase or diminish its leverage, the vibrations of the disk may be varied—shortened or lengthened.

Upon the face of the disk C is one or more or a series of radial sockets, D, the construction of which may be varied, to receive a fan, E, and to vary its angle of presentation. This fan moves vertically in the arc of a circle. To

the isolated end of a bar, *e*, secured to the frame B is adjustably or otherwise fulcrumed a fan, F, connected by a rod, *f*, to the disk or wheel C. This fan vibrates in the arc of a circle substantially at right angles to that described by the fan E.

Fig. 2 shows a disk or plate, C', provided around its circumference with apertures or perforations *g g'*, to vary the angle of presentation of the fan F, and apertures or perforations *g' g'*, relatively arranged with its center to vary the stroke of said fan.

In using the disk C', the pendent fan F is detached from the connecting-rod *f* and bar *e*, and the said disk placed upon the axis or fulcrum of the displaced fan, and the latter connected to the disk. The disk C is also removed, and the rod *f* connected directly to the crank-shaft and disk C'. The disk or plate may be arranged to work in a horizontal, perpendicular, or other position.

Depending from the disk or plate C is a pendant or arm, *h*, which passes through a lever, G, adjustably fulcrumed to the lower side of the frame B, and by which the fans H H, detachably connected to said lever, are vibrated horizontally.

I is a lever or brake, hinged to the frame B, and resting upon a leather-covered or frictional wheel, *i*, of the operating mechanism, for retarding or stopping the motion of the fans.

J is a bracket, having a pin, *j*, upon which the frame B may be mounted for supporting the fans in position against the wall, &c.

It will be observed from the foregoing that the person can be fanned in a sitting, reclining, or other position, and a greater or less current of air be obtained. The frame having the fan being susceptible of rotation, the direction of the currents of air can be changed when desired.

Having thus described my invention, what I claim, and desire to secure by Letters Patent, is—

1. In an automatic fan, a vibrating disk, C', having one or more radial sockets and slots or apertures, *g g'*, in combination with connecting-rod *f* and fan F, substantially as and for the purpose set forth.

2. In an automatic fan, the vibrating disk C, having an arm or pendant, *h*, in combina-

tion with the horizontal lever G, having a fan or fans, substantially as and for the purpose set forth.

3. In in automatic fan, the vibrating disk C, having a socket or sockets, a slot or apertures, and a pendant or arm, *h*, in combination with the connecting-rod *f*, lever G, and fans E F H, substantially as and for the purpose set forth.

4. In combination with the operating mechanism and the leather-covered or frictional wheel *i*, hereinbefore described, the retarding lever or brake I, substantially as and for the purpose set forth.

5. The vibrating disk C, having one or more radial sockets and a slot or slots, in combination with fan E, connecting-rod *f*, and fan F, substantially as and for the purpose set forth.

In testimony that I claim the foregoing as my own I hereunto affix my signature in presence of two witnesses.

JOHN HAY.

Witnesses:

ROBT. O. RYAN,

E. E. BARKER.