

H. C. HERRON.
Water Dam.

No. 198,939.

Patented Jan. 8, 1878.

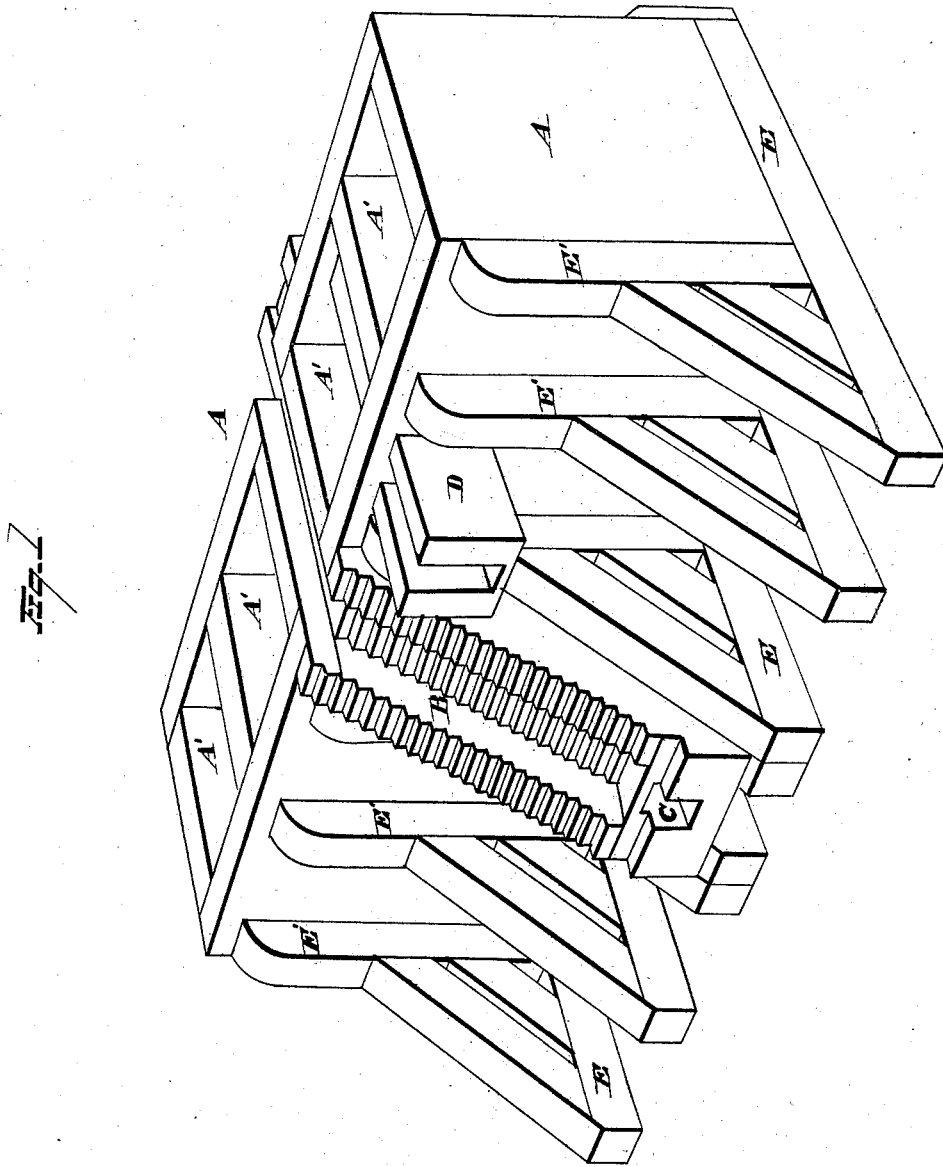

WITNESSES

Ed. S. Nottingham
A. M. Bright.

INVENTOR,

H. C. Herron.
By Dequett & Dequett
ATTORNEYS

H. C. HERRON.
Water Dam.

No. 198,939.

Patented Jan. 8, 1878.

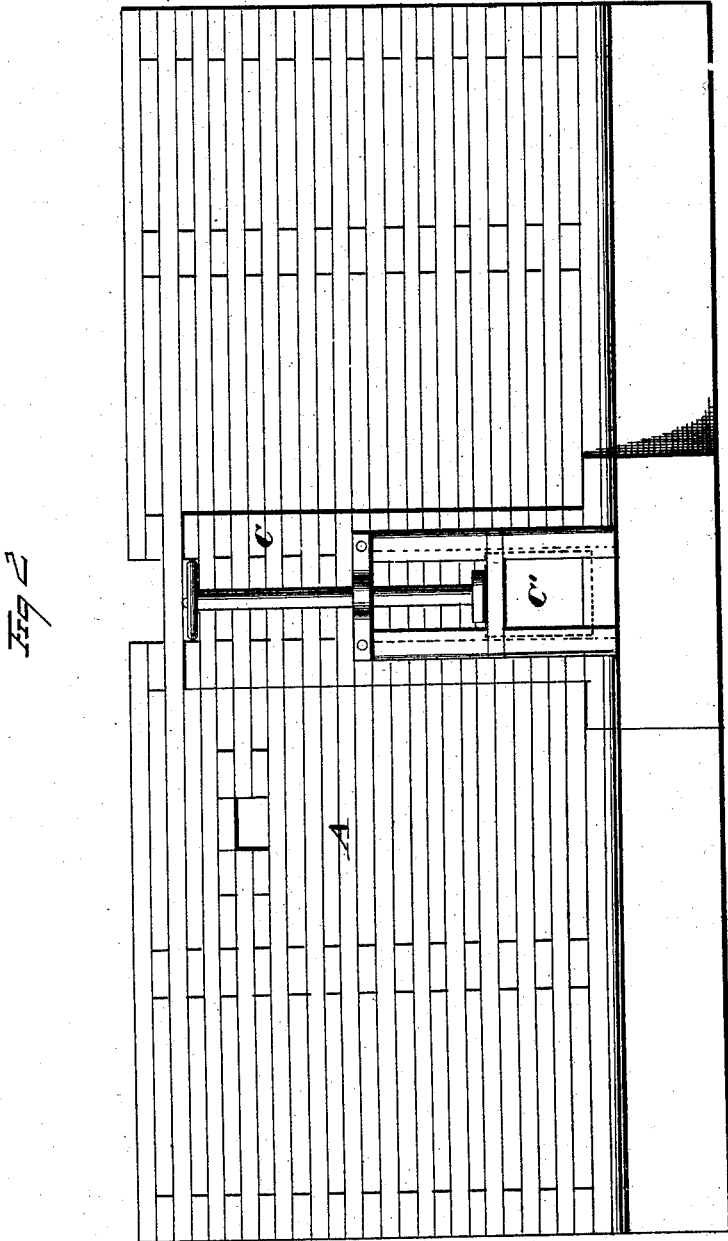

WITNESSES
Edw. J. Nottingham
A. M. Bright

INVENTOR
H. C. Herron.
By *Dequette & Dequette*
ATTORNEYS

UNITED STATES PATENT OFFICE.

HIRAM C. HERRON, OF CLEVELAND, OHIO.

IMPROVEMENT IN WATER-DAMS.

Specification forming part of Letters Patent No. **198,939**, dated January 8, 1878; application filed October 17, 1877.

To all whom it may concern:

Be it known that I, HIRAM C. HERRON, of Cleveland, in the county of Cuyahoga and State of Ohio, have invented certain new and useful Improvements in Water-Dams; and I do hereby declare the following to be a full, clear, and exact description of the invention, such as will enable others skilled in the art to which it pertains to make and use it, reference being had to the accompanying drawings, which form part of this specification.

My invention relates to water-dams.

In the drawings, Figure 1 is a perspective view of a dam according to my invention, and Fig. 2 is a rear view of the same.

My invention consists in the following parts and combinations, as hereinafter specified and claimed, wherein—

A is the main body of the dam, divided up into several compartments, A', into which compartments is to be placed earth solidly packed and tamped. B is the water-fall, or that portion of the dam where the water is permitted to overflow.

C is a sluice connecting the rear and front of the dam at or near its base. There may be more than one of these sluices C, and each one is provided at the up-stream end with a suitable valve or gate, C', whereby water may be shut off and not permitted to escape through said sluice, or whereby it may be partially shut off and governed in this manner.

D is a sluice, intended to supply water to a mill-race or the like. This sluice D is made to pass through the dam at a distance considerably higher from the base than the sluice C. The height at which the sluice D is placed is always to be determined by the desired fall of water wanted, and this may vary for different requirements. The sluice D may, like the sluice C, be provided with a governing gate or valve to control the flow of water.

I desire to call attention to my method of joining and uniting the timbers composing my dam. These timbers, before being placed in position, should be accurately faced and jointed, so that a good contact of surfaces is secured.

It will be observed that every alternate course of timber is a continuous unbroken piece, extending the entire length of the structure

(or breadth, as the case may be,) while the intermediate courses are from place to place broken to form joints with cross-timbers.

This plan of structure, so far as I am aware, is novel with myself, and it constitutes an important feature of this my invention, inasmuch as by the same I am enabled to construct a dam capable of extraordinary strength and endurance.

The material of which my device is constructed, while not forming any essential feature of my invention, I prefer to be wood of such kind as is capable of resisting both wear and tear and the destructive action of water. Prior to using it, this timber may, if desired, be treated with any preservative or antiseptic preparation.

The compartments A' comprise a general superstructure, which rests upon sills E and against abutments E'. These sills are firmly embedded in, or secured to, the bottom of the stream. The sills should project in front of the dam sufficiently to permit of a firm bracing between them and the abutments E'.

Should the necessary strength require it, there may be supplemental compartments A' added to the rear of the dam, thus affording additional anchorage to the general structure when they are filled with earth, as hereinbefore specified.

Earth is preferable to any other matter, inasmuch as it is sufficiently heavy, while at the same time it will pack close enough to prevent the passage of water through the dam. When filled with earth, the compartments A' may be covered over with timber.

The water-fall B is constructed on the same general principles, so far as concerns the manner of arranging and joining its component timbers, as the rest of the dam above described. There should be a sufficient width to the water-fall B, or a sufficient number of narrower ones, to accommodate the escape of water by this avenue, even if the sluices C and D should be closed.

It is obvious that levees or embankments to prevent the overflow of rivers may be constructed upon the principles herein specified, and I propose to apply my invention, if necessary, to this use.

For purposes of irrigation, gated or valved

sluices may be provided in the levee, whereby land adjacent may be watered at pleasure.

What I claim is—

1. A water-dam composed of the compartments A', in combination with the water-fall B, substantially as and for the purpose specified.

2. A water-dam composed of the compartments A', water-fall B, and gated or valved sluice C, substantially as and for the purposes specified.

3. The compartments A', constructed of

horizontally-laid timbers laid in regular courses, each alternate course being a continuous piece extending the entire length of the dam, substantially as and for the purpose shown.

In testimony whereof I have signed my name to this specification in the presence of two subscribing witnesses

HIRAM C. HERRON.

Witnesses:

F. TOUMEY,

W. E. DONNELLY.