

J. B. McCURDY.
 Furnace for Smelting Lead.
 No. 198,949. Patented Jan. 8, 1878.

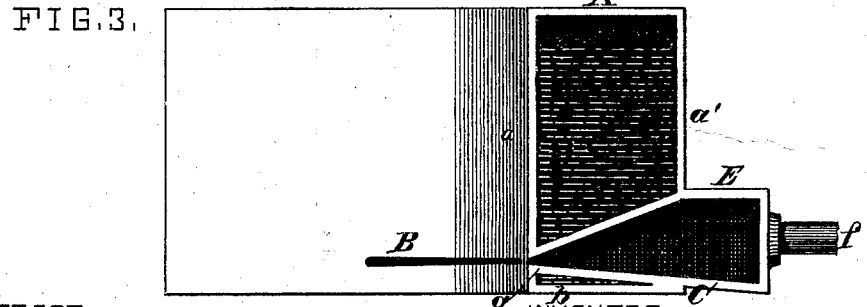
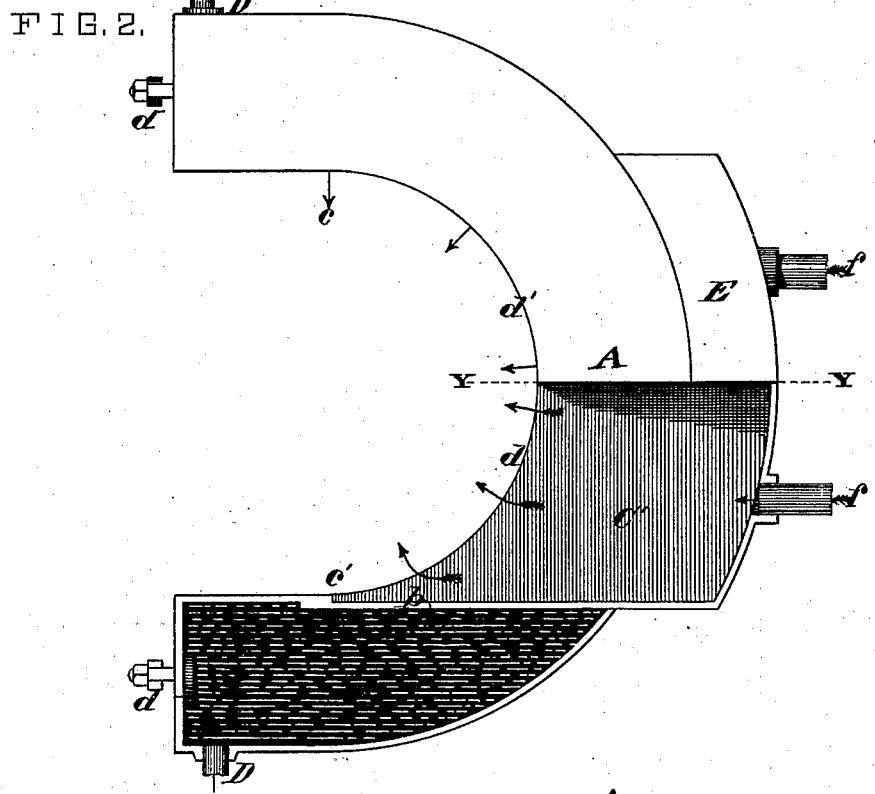
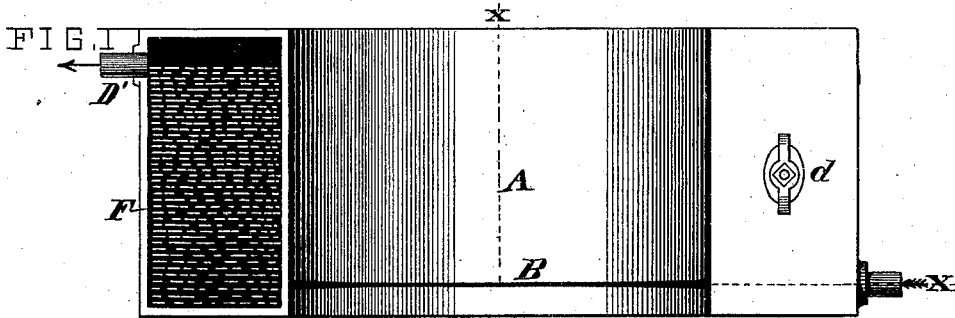

ATTEST,
Edward J. Bayker.
Alex J. Thomson

INVENTOR,
John B. McCurdy.
 By *Joseph E. Ware* Attorney

UNITED STATES PATENT OFFICE.

JOHN B. McCURDY, OF JOPLIN, MISSOURI.

IMPROVEMENT IN FURNACES FOR SMELTING LEAD.

Specification forming part of Letters Patent No. **198,949**, dated January 8, 1878; application filed October 15, 1877.

To all whom it may concern:

Be it known that I, JOHN B. McCURDY, of Joplin, in the county of Jasper and State of Missouri, have invented certain new and useful Improvements in Smelting-Furnaces; and I do hereby declare that the following is a full, clear, and exact description thereof, which will enable others skilled in the art to which it appertains to make and use the same, reference being had to the accompanying drawings, and to the letters of reference marked thereon, which form a part of this specification.

This invention relates to the arrangement of the blast-entrance into either an oval, circular, horseshoe, or square formed smelting-furnace.

In smelting lead ores, either as galena or, in an oxidized form, as carbonate of lead, the type of furnace most used for such smelting is an improved style of Scotch hearth-furnace. The best improvements added thereto are the adoption of the hollow back and the use of water within the hollow space in lieu of the former solid jamb-stones.

With the application or manner of the blast as applied to the improved Scotch hearth the satisfaction has been but partial. The single tuyere was used for half a century. Multiplied tuyeres or blast-holes have added to the quantity of lead made in a stated time. The difficulty is nevertheless still existing with the many tuyered or tuyere system which existed with the old single-tuyere furnace. In the single-tuyere furnace the blast to be effective needed to be strong. A high heat but small focus of action was the result, whereas on either side of this focal intensity were always to be found cold corners, or places to which but a low degree of heat extended. The ore, by stirring up every ten minutes, could, in time, be brought within the reductive zone. Incessant labor on the part of the "rack-hand" is, however, required to keep the melted matter from congealing against the "dead-walls" of the hearth.

It was found that the difficulty arising from the single-tuyered blast could be measurably avoided in the use of several tuyeres. Without doubt, the increase from one to several tuyeres lessened the trouble as to freezing on

the "dead-sides" between the tuyeres. Still, though relatively less, the evil had only in part been remedied.

After many years' experience with the several kind of hearth-furnaces in use, I have found that the effect of a blast, when discharged through a continuous slit or orifice which nearly incloses the charge, as shown in the accompanying drawing, very nearly meets the requirements.

My improvement is fully set forth in the following specification and accompanying drawing, in which—

Figure 1 is a vertical section with my improved slot-blast orifice clearly shown. Fig. 2 is a plan view, partly in section; and Fig. 3 is a semi-section through at the vertical line X, Fig. 1.

I exhibit only the back, the basin and hearth-stone not being at all referred to.

A is the furnace-back; *a a'*, inner and outer furnace-walls. B is the blast-slit, with a contracted center, *b b*, water-way under floor C. C is the floor of the air-chamber; *c c*, terminating point of blast-slit; D, pipe supplying water to chamber F; D', exit-pipe; *d d*, hand-holes; E, air-box; F, space between walls *a* and *a'*, usually eight inches clear; *f f*, blast-pipes.

The object of my invention is to furnish, in a greatly-extended line, a blast which shall meet the conditions required to prevent any possible chilling through any of the usual causes.

C' is a semicircular air-box, which extends from *c* to *c'*, Fig. 2, on the top of this box, and cast with an inner and outer wall. (Designated *a* and *a'*, Fig. 3.) The floor of the box C is slightly elevated, as shown, *g*, Fig. 3. The elevation thus given permits the formation of a hollow space underneath, which, allows water to pass between the wall *a* and *a'*, and underneath the floor of C' at the openings *b b*. There is from *c'* to *c* a wedge-shaped space, as shown, Fig. 3. Into this space the air-blast is driven through pipes *f f*.

It will be observed that the blast-slit B is contracted toward its center. The object of this contraction is to obtain uniform action of the blast. Air, like water, will most freely pass through the outlet which is nearest to the inlet. The

slit is of equal size, and would therefore discharge the largest quantity of air into the charge near d' . To prevent this consequence the slit-orifice B is contracted from both its ends into the center.

The action upon a smelting-charge by the use of my improved slit-orifice is very marked. A thin unbroken sheet of air is forced into the charge without any irregularity of pressure, and the focus of reduction is proportionately widened, and also the usual labor in stirring up the charge every eight or twelve minutes is much reduced, since the charge is cut down so uniformly by the blast action that it is not required that fresh parts of the charge be continually presented by stirring.

The operation of my furnace is best when the action of the air-sheet is but slightly above the level of the metal in the usual basin, and the floor C of the air-box should to that end be but little above the horizontal, or only raised

to permit a thin stream of water to pass through the water-way underneath.

What I claim as my invention is—

1. The furnace constructed to form a blast-slit or opening, B, contracting from its ends to its center, substantially as described.

2. The furnace constructed to form the blast-slit B, in combination with the water-chamber F and water-way b , as and for the purposes herein described.

3. The furnace constructed to form a blast slit or opening, B, the water-reservoir F, water-way b , and blast-chamber C, as described.

In testimony that I claim the foregoing as my own invention I affix my signature in presence of two witnesses.

JOHN B. McCURDY.

Witnesses:

J. G. HARKLERODES,
S. S. BISSELL.