

S. METCALFE.
Wool-Combing Machines.

No. 198,950.

Patented Jan. 8, 1878.

Fig. 1.

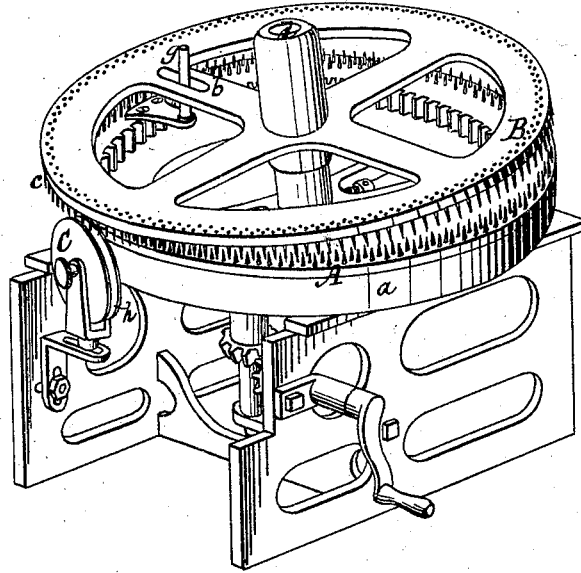
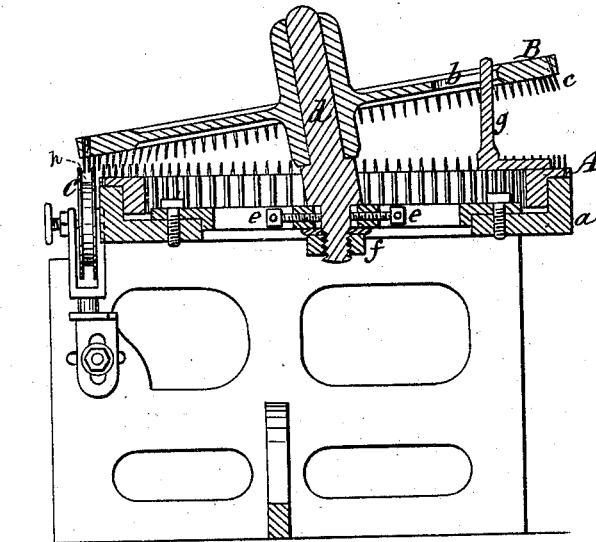

Fig. 2.



Witnesses
Philip T. Garner
W. C. Chaffin

Inventor:
Samuel Metcalfe
By Wm. Wood
Attorney.

S. METCALFE.
Wool-Combing Machines.

No. 198,950.

Patented Jan. 8, 1878.

Fig. 3.

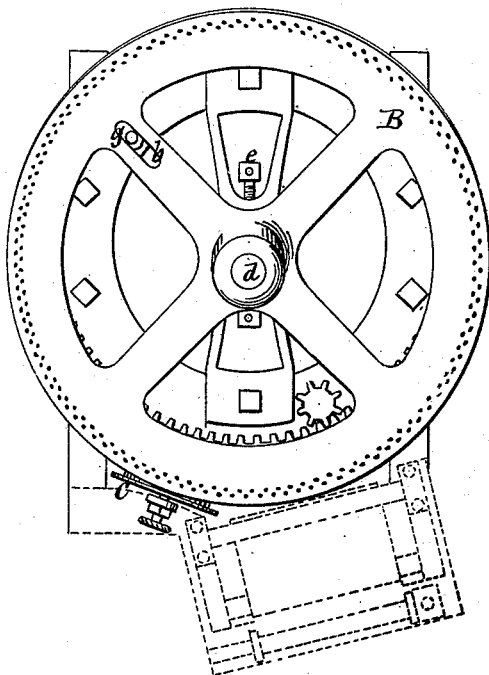

Witnesses
Philip J. Larner
A. E. Chaffin

Inventor:
Samuel Metcalfe
By Wm. Woods
Attorney

UNITED STATES PATENT OFFICE.

SAMUEL METCALFE, OF POQUONOCK, CONNECTICUT.

IMPROVEMENT IN WOOL-COMBING MACHINES.

Specification forming part of Letters Patent No. **198,950**, dated January 8, 1878; application filed July 11, 1877.

To all whom it may concern:

Be it known that I, SAMUEL METCALFE, of Poquonock, in the town of Windsor, in the county of Hartford and State of Connecticut, have invented certain new and useful Improvements in Wool-Combing Machines; and I do hereby declare that the following specification, taken in connection with the drawings furnished and forming a part of the same, is a full, clear, and exact description thereof.

The machines to which my improvements are specially applicable are those in which a revolving toothed annulus is employed, as in the well-known "Lister wool-comber."

In those machines the wool, in a previously prepared sliver, is fed to the toothed annulus, and worked in such a manner that the combed ends of the wool extend outward from the periphery of the revolving annulus, and the long portion of the wool is withdrawn from the teeth thereof by drawing-off mechanism as rapidly as the wool arrives at a certain point.

In Letters Patent of the United States No. 185,772, granted to me December 26, 1876, I show and describe certain improvements made by me on this class of machines, whereby the butts of the wool held by the teeth of the annulus are transferred to the teeth of an overlying and revolving gill-comb, from which nearly all the wool is withdrawn by the drawing-off mechanism, and the butts of the wool more thoroughly combed than when drawn directly from the toothed annulus.

The prime object of my present invention is to provide more fully for the combing of the butts than has heretofore been accomplished; and to that end my invention consists, mainly, in the combination, with the lower comb or carrier, to which the wool is fed from the sliver, and which secures and carries the wool while its outward projecting ends are combed, of a gill-comb having teeth which are parallel with the teeth of the lower comb, adjacent to the drawing-off mechanism, and which, at that point, move in the same plane with said teeth, between them and the drawing-off mechanism, whereby the butts of the wool, as it is drawn off, are operated upon by the teeth of both combs, and therefore

more thoroughly combed than when drawn simply from the teeth of the lower comb or toothed annulus, as in the Lister, or from the overlying gill-comb, as in machines embodying my previously patented improvements.

In order that the teeth of the upper comb may occupy the position described with relation to the teeth of the lower comb and the drawing-off mechanism, it is obvious that said upper comb, if in a circular form, must be of a greater diameter than the lower, and that if the upper comb were placed parallel with the lower, with its teeth outlying those of the lower, and in the same plane, the lower comb would be wholly inaccessible for receiving wool from the feeding mechanism; and therefore I mount the upper comb on a central inclined stud, so that the comb will revolve in an inclined plane with its lower side adjacent to the drawing-off mechanism, which affords an ample vertical space between the two combs for the operation of the feeding and clearing mechanism.

If the teeth of the upper comb were set at right angles to the body of the comb, as in the case of the lower comb, they would project inward at the lowest side of the comb, and would not be parallel with the teeth of the lower comb, and therefore the teeth of the upper comb are set projecting outward at an angle corresponding with the incline of the comb, so that its teeth, when at the lowest side thereof, are truly parallel with the teeth of the lower comb.

In order that the teeth of the upper comb may be adjusted to and from the teeth of the lower comb for operating on long and short wool, the inclined stud or axis of the upper comb is made adjustable in its seat. The long ends of the wool projecting outwardly from the lower comb have a tendency to fall more or less; and in order to secure the engagement of the wool with the teeth of the upper comb, I provide a lifter-wheel, which is placed outside the lower comb at one side of the drawing-off mechanism, over which the wool is carried and lifted into the teeth of the upper comb, which occupy in their movement an annular groove in the periphery of the lifter-wheel provided to receive them, the tops

of the groove serving as supports for the wool inside and outside of the rows of teeth.

The teeth of both combs, operating conjointly and at the same time, render it essential that they should revolve at precisely the same speed, and I have devised a simple means for operatively connecting them, so that the lower shall properly drive the upper comb. This I accomplish by providing in the upper comb, between its axis and rim, a radial slot, and upon the upper side of the lower comb I provide a vertical stud, which passes through the slot in the upper comb. This stud has sufficient height to engage with the upper comb on its highest side, and therefore, although during the revolution of the combs the stud occupies a constantly-varying position with relation to the ends of said slot, both combs are moved together and at the same speed without the intervention of gearing, as in my Letters Patent before referred to.

To more particularly describe my invention, I will refer to the accompanying drawings, in which—

Figure 1, Sheet 1, represents, in perspective, so much of a wool-combing machine as is necessary to illustrate my invention. Fig. 2, Sheet 1, represents the same in central vertical section from front to rear of the machine. Fig. 3, Sheet 2, represents the same in top view.

A denotes the toothed annulus or lower comb. It is mounted upon a hollow steam-bed, *a*, supported by the frame of the machine, and revolved by internal gearing in a manner well known.

B denotes the upper comb, which is in the form of a wheel, with arms from hub to rim. One of its arms has a radial slot, as at *b*. The teeth *c* of this comb are so set that they project downward and outward. The hub has a long bearing for its axis *d*, and this latter is inclined, as shown, so that when the comb is mounted thereon it is similarly inclined, affording, for about half its circumference, a space between it and the lower comb sufficiently large to admit of the proper operation of such feeding and clearing mechanism as is employed, for instance, in the Lister machine.

The axis or stud *d* is seated in a slot in a cross-bar of the frame of the machine, and provided with set-screws *e* and a nut, *f*, whereby it may be adjusted for bringing the lowest portion of the upper comb into any desired position with relation to the teeth of the lower comb.

It will be understood that the drawing-off mechanism is located, as indicated in dotted lines in Fig. 3, adjacent to the point where the teeth of both combs are parallel and engaged with the wool; and it will be seen that as the wool is drawn off it will be pulled through the teeth of both combs. The two combs move together, they being connected

by means of the vertical stud *g*, which is mounted on the upper side of the toothed annulus or lower comb, and projects upward through the slot *b* in one of the arms of the upper comb.

The lifter-wheel C, mounted on a horizontal axis, is located at one side of the drawing-off mechanism, in close proximity to the periphery of the lower comb, and with its groove or annular recess *h* occupied by the teeth of the upper comb. The edges of the lifter-wheel support the outer ends of the wool which is held by the butts in the teeth of the lower comb, and cause the wool to be well forced into the upper teeth without disengaging it from the lower teeth. The lifter-wheel is mounted on a bracket provided with bolts and slotted connections, whereby it may be accurately adjusted with relation to the upper comb, and, if mounted on delicate centers, it will revolve at a speed corresponding with that of the combs through the frictional contact of the moving wool; or it may be driven by a belt or cord.

As previously stated, my improvements are particularly adapted to the Lister machine; but I am well aware that my inclined upper comb may be employed in connection with the well-known jointed traveling comb or carrier, provided the inclined comb has a diameter greater than that of the half-circle occupied by the semicircular track or guide of the jointed comb, as is usual, at each end of machines of that class; and I do not therefore limit my invention to the combination of my improvements with the toothed annulus of Lister, because it is only a small portion of said annulus which at any one time co-operates with the upper comb, and because substantially the same results would be attained if it were combined with the jointed comb, in that two sets of teeth would then be employed for combing out the butts of the wool during the drawing-off operation, as in the Lister machine.

Machines embodying my present improvements are of particular value for operating upon medium and coarse stock, but can be profitably employed on the finer grades of wool.

Having thus described my invention, I claim as new and desire to secure by Letters Patent—

1. In a wool-combing machine, the combination, with a main lower comb or carrier, of an overlying revolving gill-comb, which presents a portion of its teeth in the same plane with the teeth of the lower comb, and parallel therewith, substantially as described, whereby the wool in being drawn off is operated upon by the teeth of both combs, as set forth.

2. The combination, with the lower comb, of an upper circular comb, which revolves in an inclined plane and has inclined teeth, substantially as described.

3. The combination, with the lower and the upper comb, of the grooved lifter-wheel, sub-

stantially as described, whereby the wool is pressed into the upper comb without being released from the lower comb, as set forth.

4. The inclined upper comb mounted on an inclined axis, which is adjustable in its seat, substantially as described.

5. The combination, with a circular comb having a radial slot between its hub and rim, of a revolving lower comb provided with a

vertical stud, which occupies the slot in the upper comb, substantially as described, whereby the two combs are operatively connected and simultaneously revolved by gearing applied to the lower comb, as set forth.

SAMUEL METCALFE.

Witnesses:

R. D. CASE,

THOS. B. HATHEWAY.