

H. H. BOURNE.
 Portable Limekilns.

No. 198,964.

Patented Jan. 8, 1878.

Fig. 1.

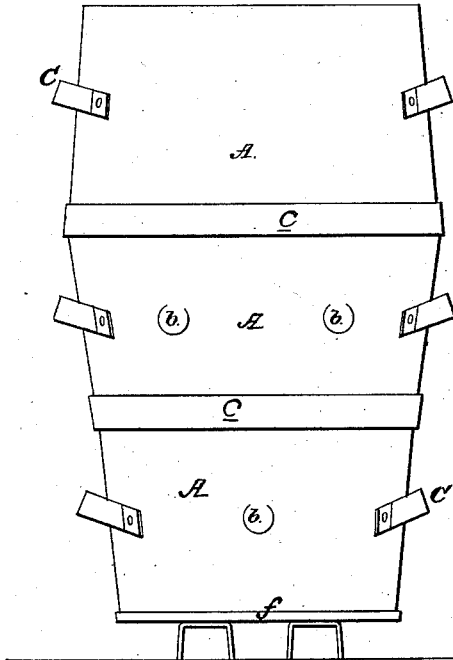

Fig. 2.

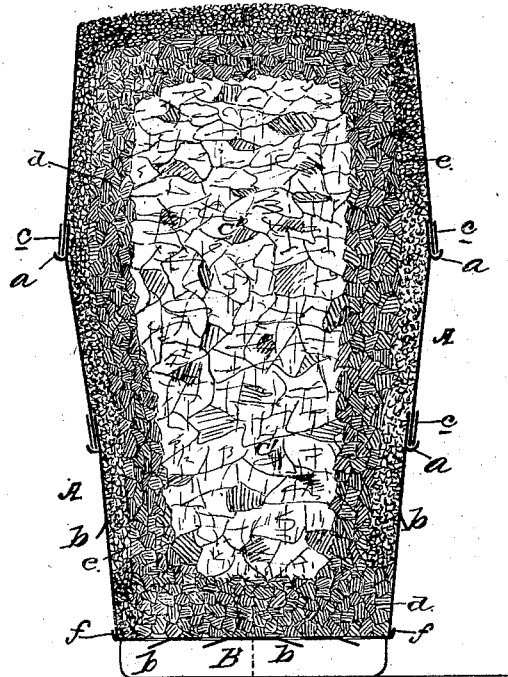
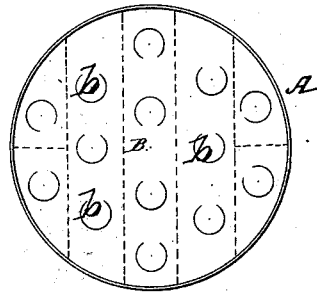

Fig. 3.



Attest.

H. E. Smith
F. A. Stuges

Inventor:

Henry H. Bourne.

UNITED STATES PATENT OFFICE.

HENRY H. BOURNE, OF CLOUD COUNTY, KANSAS.

IMPROVEMENT IN PORTABLE LIMEKILNS.

Specification forming part of Letters Patent No. **198,964**, dated January 8, 1878; application filed January 2, 1877.

To all whom it may concern:

Be it known that I, HENRY H. BOURNE, of Cloud county, in the State of Kansas, have invented a new and useful Improvement in a Lime-Burning Apparatus, which improvement is fully set forth in the following specification, reference being had to the accompanying drawings, and in which—

Figure 1 is a side elevation of my improved portable apparatus for making lime. Fig. 2 is a vertical section, and Fig. 3 an inverted view, of the same.

Corresponding parts in the several figures are denoted by like letters.

This invention relates to a certain improvement in apparatus for making lime, the object of which is to provide for steady and uniform combustion and the detachability of the parts; and it consists, principally, of two or more sections, of suitable capacity, disposed one upon the other, the lower one having supporting-flanges, which receive the lower edge of the upper section, wedged or fastened therein by bands placed around the latter section, and inserted in the supporting-flanges, substantially as hereinafter more fully set forth.

In the annexed drawing, A A refer to two or more sections, constituting an apparatus of proper capacity, and made of any suitable material and shape. These sections are disposed one upon the other, and supported, each succeeding one, upon upwardly-curved flanges *a a*, fastened to the one next below, and within which they are wedged or confined by bands or straps *c c*, placed around the said sections, and inserted into the said flanges *a a*, as seen in Fig. 2.

By simply removing the bands or straps *c c*, it will be seen that the respective sections

can be readily taken apart, to allow the apparatus to be easily transported.

B is the bottom, having a flange, *ff*, projecting up around the lowest section. In the bottom B and sides of one or more of the several sections A A are slits or openings, to create a steady and uniform draft through the apparatus. The sections are provided with handles or bails C C, by which they may be lifted off and upon each other, in taking them apart and putting them together.

The limestone C' C' is arranged or put in the center of the apparatus, the coal *dd* around it, and around the coal *dd* is placed the slack-coal *e e*.

It will be seen that this apparatus is adapted to burn slack-coal and coal-seeings, thus utilizing what would otherwise prove to be a waste.

It will also be remarked that as the contents of the apparatus become converted into lime, that portion thus converted can be removed without having to wait until the whole is burned.

Having thus described my invention, what I claim, and desire to secure by Letters Patent, is—

1. The perforated or imperforated sections A A, in combination with straps or bands *c c*, substantially as and for the purpose set forth.

2. The perforated sections A A, provided with handles C C and perforated bottom or grate B, substantially as and for the purpose set forth.

HENRY H. BOURNE.

Witnesses:

H. E. SMITH,
F. W. STURGES.