

F. B. BOALT.  
Hay-Press.

No. 199,021.

Patented Jan. 8, 1878.

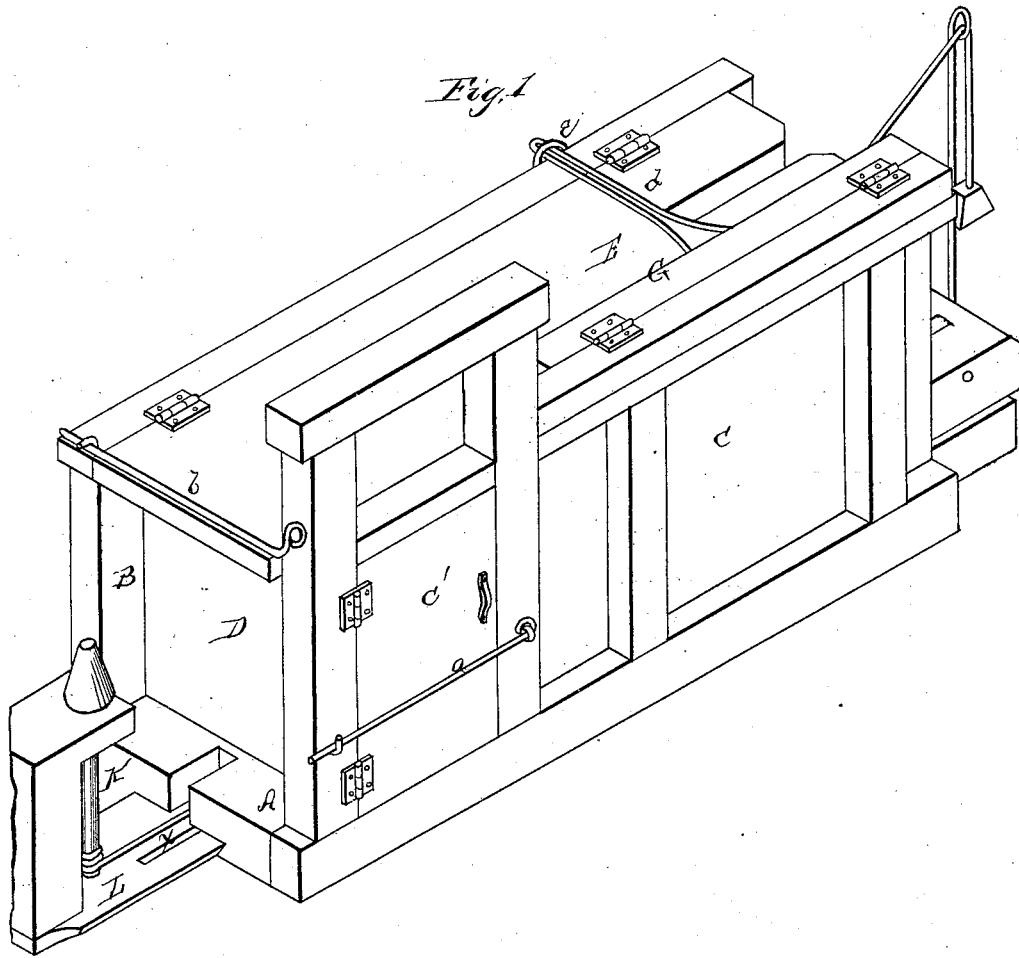

Witnesses:  
*H. B. McArthur*  
*C. L. Evert*

Inventor  
*F. B. Boalt.*

per

*J. H. Alexander & Elliott.*  
 Attorneys,

F. B. BOALT.  
Hay-Press.

No. 199,021.

Patented Jan. 8, 1878.

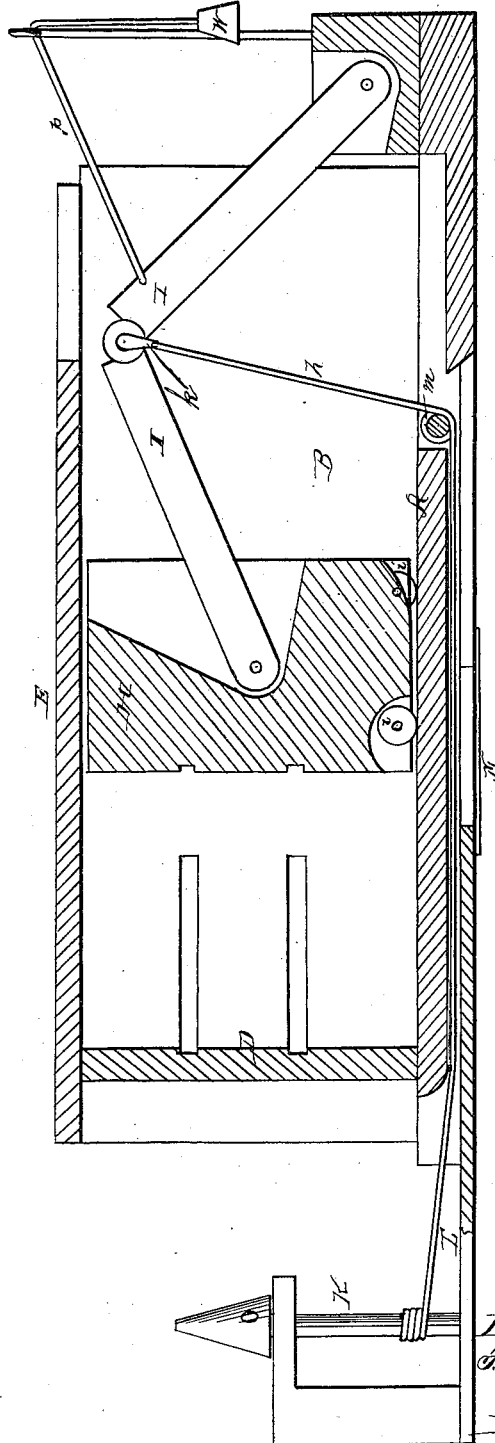

*Fig. 2.*

*Witnesses:*  
*H. C. McArthur,*  
*C. L. Evers*

*Inventor,*  
*F. B. Boalt,*  
*Per*

*J. H. Alexander Halliott,*  
*Attorneys.*

# UNITED STATES PATENT OFFICE.

FRANCIS B. BOALT, OF BAINBRIDGE, NEW YORK.

## IMPROVEMENT IN HAY-PRESSES.

Specification forming part of Letters Patent No. **199,021**, dated January 8, 1878; application filed November 26, 1877.

### *To all whom it may concern:*

Be it known that I, FRANCIS B. BOALT, of Bainbridge, in the county of Chenango and State of New York, have invented certain new and useful Improvements in Hay-Presses; and I do hereby declare that the following is a full, clear, and exact description thereof, reference being had to the accompanying drawings, and to the letters of reference marked thereon, which form part of this specification.

The nature of my invention consists in the construction and arrangement of a hay-press, as will be hereinafter more fully set forth.

In order to enable others skilled in the art to which my invention appertains to make and use the same, I will now proceed to describe its construction and operation, referring to the annexed drawings, in which—

Figure 1 is a perspective view of my press, and Fig. 2 is a vertical section through the same.

A represents the bottom of the press, on which are firmly framed and secured the back B and front C, as well as one end piece, D, as shown. At this end of the box thus formed in the front C is a hinged door, C', which, when closed, is fastened by means of a rod or lever, *a*.

E is the top of the press, hinged to the back B, and held down at one end by a rod or lever, *b*.

A bar, G, is hinged to the front C, which bar is to be closed down onto the front edge of the top E, and from said bar extends a rod or arm, *d*, over the top of the press, said rod or arm being there held by a link, *e*, as shown.

H represents the follower, which is provided with rollers *i i*, upon which it moves, to reduce the friction. The follower may also have rollers on the top, and also on the sides, if desired, to still further reduce the friction.

The follower H is, by means of jointed or toggle levers I I, connected with a post or piece, J, on the outside of the press, just beyond the open end thereof.

In the joint or hinge of the two levers I I is suspended a clevis, *k*, from which a rope or chain, *h*, passes downward through a slot in the bed or bottom A, around a pulley, *m*, and to a windlass, K, as shown. This windlass is mounted on a slide, L, which moves in a suit-

able dovetailed recess made in the under side of the bed A, so that it can be pushed in or drawn out, as required. It is to be drawn out for use, and its movement may be limited by means of a pin projecting downward from the base into a longitudinal slot, *x*, in the slide. When drawn out to its fullest extent a spring, M, comes up against its inner end and holds it in place.

The front door C' being closed and the follower H drawn back, the top door E is opened, when the hay or other material to be pressed is placed in the box. The top is then closed, and, by means of the windlass, the toggle-levers are extended, which forces the follower forward until the levers are on a line, when the bale is pressed. It is then tied in the usual manner, and removed by opening the door C'. The follower is then drawn back by means of a cord or chain, *p*, attached to one of the levers I, and passing upward over a pulley, which may be mounted in a post connected to the press, or in a beam or rafter overhead, said rope having a weight, W, attached to its other end. This weight should balance the follower, so that very little force will be required to draw back the follower.

When the press is not in use the slide L with the windlass is pushed inward, so as not to take up so much room.

Having thus fully described my invention, what I claim as new, and desire to secure by Letters Patent, is—

1. The combination, with the bale-box A B C D, of the hinged door C', hinged top E, rods or levers *a b*, hinged bar G, arm *d*, and link *e*, all constructed substantially as and for the purposes herein set forth.

2. The combination of the follower H, mounted upon rollers, the toggle-levers I I, clevis *k*, rope *h*, and windlass K, mounted upon a slide, L, and held in position for operation by the latch M, all substantially as and for the purposes herein set forth.

In testimony that I claim the foregoing as my own I affix my signature in presence of two witnesses.

FRANCIS B. BOALT.

Witnesses:

CHARLES B. SIMMS,  
FRANLIN B. PHINNEY.