

C. & J. G. BRUNNER.
Fire-Escapes.

No. 199,026.

Patented Jan. 8, 1878.

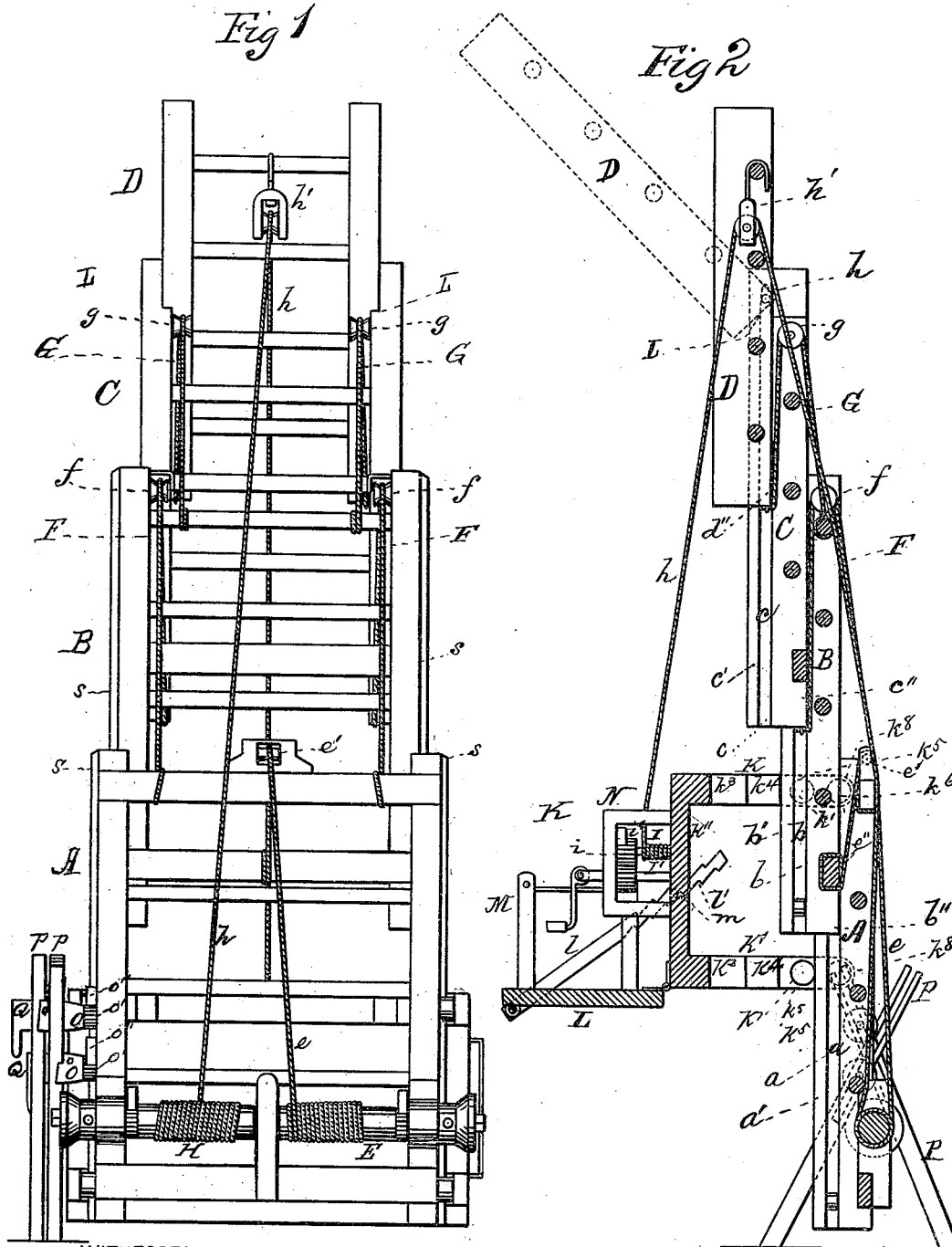

WITNESSES
Mo. S. Utley.
A. J. Clark

INVENTORS
Christian Brunner,
John G. Brunner,
by E. W. Anderson,
 ATTORNEY

UNITED STATES PATENT OFFICE.

CHRISTIAN BRUNNER AND JOHN G. BRUNNER, OF NEWTON, IOWA.

IMPROVEMENT IN FIRE-ESCAPES.

Specification forming part of Letters Patent No. **199,026**, dated January 8, 1878; application filed June 23, 1877.

To all whom it may concern:

Be it known that we, CHRISTIAN BRUNNER and JOHN G. BRUNNER, of Newton, in the county of Jasper and State of Iowa, have invented a new and valuable Improvement in Fire-Escape, Painting, and Hoisting Ladders; and we do hereby declare that the following is a full, clear, and exact description of the construction and operation of the same, reference being had to the annexed drawings, making a part of this specification, and to the letters and figures of reference marked thereon.

Figure 1 of the drawings is a representation of a front view of our invention, and Fig. 2 is a longitudinal central section thereof.

This invention relates to improvements in fire-escapes and extension-ladders; and consists in a series of ladder-sections which, by the operation of a windlass, ropes, and pulleys, are raised simultaneously one upon another.

The details of construction involved in our improvements will be hereinafter fully explained with reference to the accompanying drawings, in which the same letters of reference designate identical parts in the different figures.

A, B, C, and D are the ladder-sections forming the extension-ladder, the bottom section A being the widest, and each of the others being narrower than, and fitting between the rails or side pieces of, the section below it. The rails of each ladder-section are considerably wider than is necessary for the support of the wings, and, except those of the top section, are provided with longitudinal grooves in the inner sides of their projecting portions, as shown at *a b c*. The portions of the rails between the grooves and the outer edges of said rails are of equal width with the grooves, and form splines at *a' b' c'*. The rails, except those of the bottom section, are similarly grooved on their outer sides, but near their inner edges forming splines, as shown in dotted lines at *b'' c'' d''*. The inner splines of the wider sections fit and slide in the outer grooves of the narrower sections, while the outer splines of the narrower sections fit and slide in the inner grooves of the wider sections. The splines and grooves of the section C do not extend entirely to the tops of the rails. Near their tops the inner sides of the rails of said

section are partially cut away, so that when the splines of top section D pass out of the grooves or sections C the top section may be inclined, as shown in dotted lines in Fig. 2, its feet resting upon shoulders L L. This arrangement enables the top ladder-section to be inclined against or near to the wall of a house beside which the apparatus may be reared.

It will be understood that our extension-ladder may be constructed with as many intermediate sections as desired and permitted by the nature of materials used, the construction of the top and bottom sections being substantially as shown and described, whatever may be the number of intermediate sections.

Near the foot of and journaled upon the bottom ladder-section A is a windlass, E, from which a rope, *e*, passes over pulley *e'* on the top of the bottom ladder, and is fastened to the bottom stay-bar *e''* of ladder-section B. F F are ropes attached to the top stay-bar of section A, and, passing over pulleys *f f* at the top of section B, are fastened to the feet of the rails of section C, while G G are ropes attached to the top round of section B, and, passing over pulleys *g g* at the top of section C, are attached to the feet of rails of section D. H is a windlass, also journaled upon and near the foot of bottom section A. From this windlass a rope, *h*, passes upward and through a block, *h'*, hung to the top round of the top ladder-section, and downward to another windlass, I, located upon the carriage K. The block *h'* may be hung upon any round of either of the ladder-sections. K is a carriage or adjustable scaffold, which may be raised upon the extension-ladder to any desired height by means of either windlass H or I. When the windlass I is used it is operated, of course, by a person upon the carriage. The body of carriage K consists of horizontal top and bottom walls *k k'* and a vertical side wall, *k''*. In each of the horizontal walls is a notched recess, embracing the extension-ladder, the notches *k³*, *k⁴*, *k⁵*, and *k⁶* fitting to the outer sides and edges of the rails of the sections, *k³* fitting the narrowest, and the other notches, successively, the wider, sections. The notches *k⁵* and *k⁶* are provided with friction-wheels *k⁷* *k⁸*, which turn against longitudinal shoulders

s s at the inner edges of the outer sides of ladder-sections A and B.

All the notches may be provided with friction-wheels, and all the ladder-sections with shoulders similar to those of sections A and B.

At the foot of the vertical wall k'' of the carriage K is hinged a platform, L. To the ends of this hinged platform are pivoted notched bars l , the notches l' of which catch upon pins m , which project from the ends of the vertical wall k'' . By means of these notched bars and pins the platform may be adjusted at any desired inclination, or to a horizontal position when the ladder is inclined.

M is a railing upon the platform. To the front of the vertical wall k'' of the carriage K is attached a frame, N, in which is arranged the windlass I, on the end of which is a gear-wheel, i , provided with a pawl, i' , and meshing with another gear-wheel on a shaft, I' , which shaft is provided with a winch.

From one side of the bottom ladder-section A project two short rods or axles, upon which are mounted rollers O O, having their outer ends bifurcated, or provided each with a diametric recess, as shown at $o o$, and their inner ends provided with ratchet-wheels $o' o'$, into which take pawls $o'' o''$, pivoted to the rail of the ladder-section A.

P P are braces, the upper ends of which are forked or slotted, as shown at $p p$. These braces pass through the diametric recesses or open slots in the ends of the rollers O O, and the axles of said rollers pass through the slots $p p$ of the braces. The ends of said axles or rods are screw-threaded and provided with nuts Q Q. The function of the braces is to support and steady the ladder, and, by reason of the slots in their ends and their longitudinal adjustability through the recesses in the ends of the rollers O O, they may be shortened or lengthened to suit the ground, and the turning of the rollers admits of said braces being adjusted to any desired angle at which they may be held by the pawls and ratchets at the inner ends of the rollers. Tightening of the nuts Q Q prevents longitudinal displacement of the braces.

The bottom ladder-section A may be provided with a wheel at the foot of each rail, or may stand upon a truck, for purposes of transportation.

The operation of our invention is as follows: Suppose the object to be to extricate persons from a burning house. The apparatus is conveyed from its station in a closed-up condition, the ladder-sections being slid snugly home, one within another. On arriving within a suitable distance of the house the ladder is placed in proper position, and thus braced by means of the adjustable braces P P. A winch or other suitable means of turning it is then applied to windlass E, the turning of which winds upon it rope e , which

passes over pulley e' , and thus elevates ladder-section B, which slides up within the rails of bottom ladder-section A. As the section B rises the pulleys $f f$ at its top press upward upon ropes F F, which are firmly fastened to the top of section A, thus causing section C (to the feet of the rails of which the other ends of ropes F F are fastened) to slide upward within section B, and section D is caused to slide upward within section C in a similar manner, as will be readily understood.

Each section is provided with a suitable stop to prevent it from passing out from between the rails of the next house-section.

It will be seen that from the peculiar arrangement of ropes and pulleys the movable sections of the ladder will all be in process of extension at the same time. They may be adjusted to any desired height, the hoisting-windlass being provided with a pawl and ratchet for retaining it in position.

When the ladder is fully extended the top section may be inclined against or toward the wall of the house, as hereinbefore explained, and as shown by the dotted lines, Fig. 2.

The turning of windlass H winds upon it the rope h , which passes through block h' , and is attached to windlass I upon carriage K, and thus may elevate the said carriage to any position convenient for the escape of persons from windows, roofs, and the like, a pawl and ratchet preventing windlass H from turning backward when not desired.

A person on the carriage K may raise it by means of the windlass I, as before explained.

The carriage may be reversed or turned upside down in order to bring the platform to a higher point. In this arrangement the railing would require to be changed to the opposite side of the platform, of course, and several other alterations be made, which are too obvious to need explanation.

Having now fully explained the construction and operation of our invention, what we claim as new, and desire to secure by Letters Patent, is—

1. In combination with an extension-ladder and fire-escape composed of the lapping ladder-sections A B C D, a carriage, K, having the recessed top and bottom walls, and provided with rollers, substantially as specified.

2. The combination of adjustable slotted braces P P with adjustable rollers O O, having recessed ends, substantially as specified.

In testimony that we claim the above we have hereunto subscribed our names in the presence of two witnesses.

CHRISTIAN BRUNNER.
JOHN GEORGE BRUNNER.

Witnesses:

J. M. BROWN, M. D.,
B. F. FAILOR.