

W. H. KAIN.  
Brick-Machines.

No. 199,072.

Patented Jan. 8, 1878.

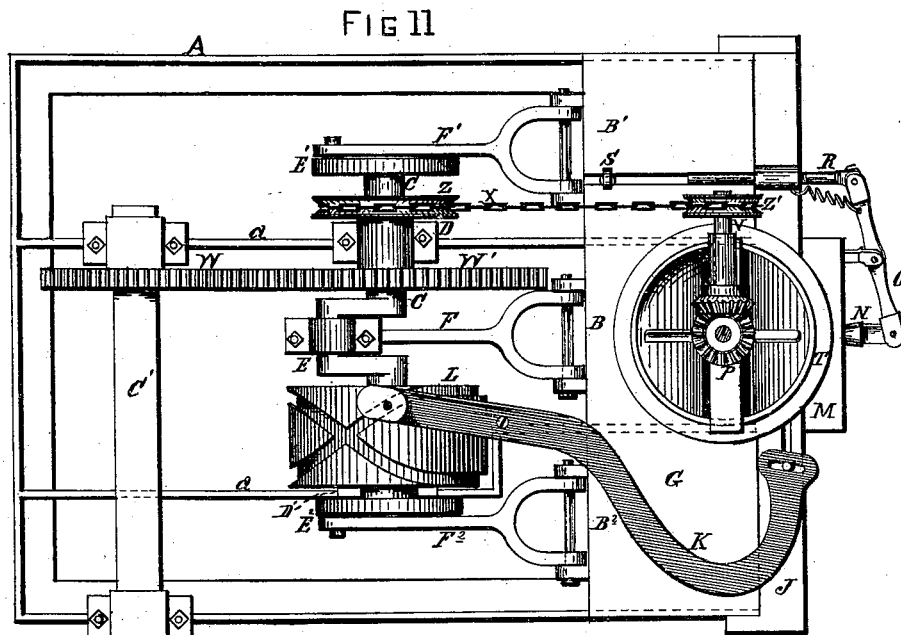
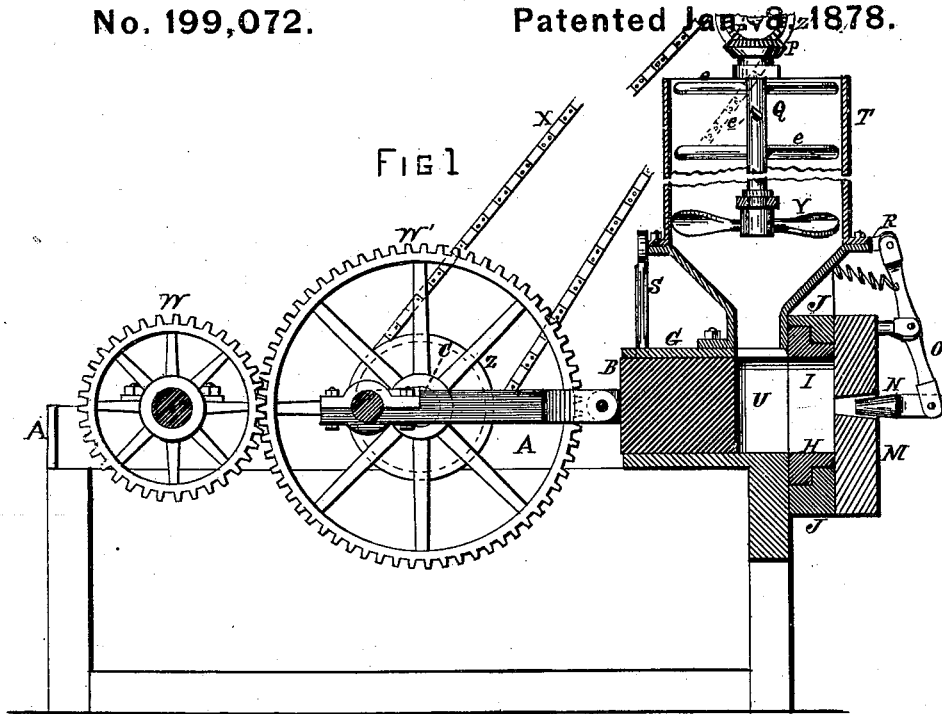

WITNESSES.  
*Wm H Getty*  
*W H Keyes*

*William H. Kain,*  
 INVENTOR.  
*By Isaac R. Clark,*  
 his Attorney.

W. H. KAIN.  
Brick-Machines.

No. 199,072.

Patented Jan. 8, 1878.

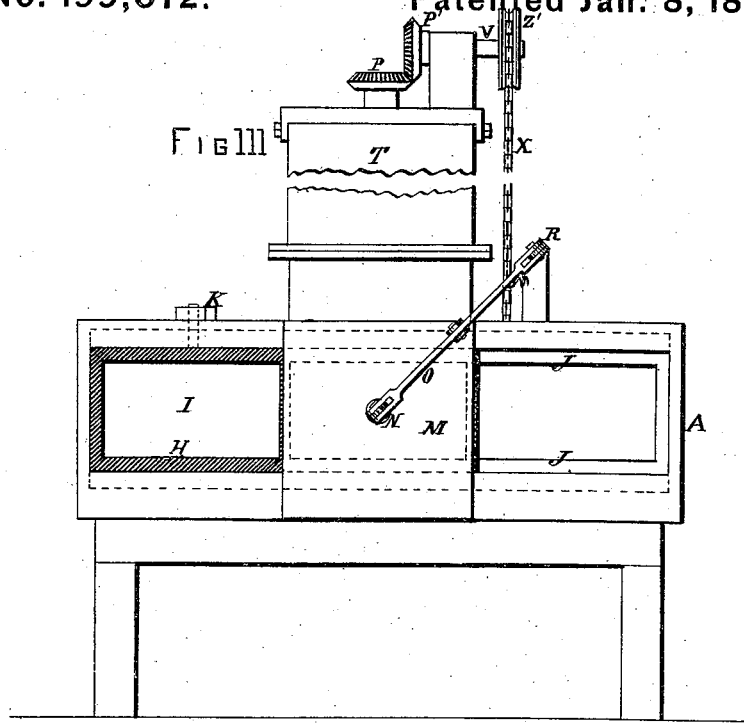
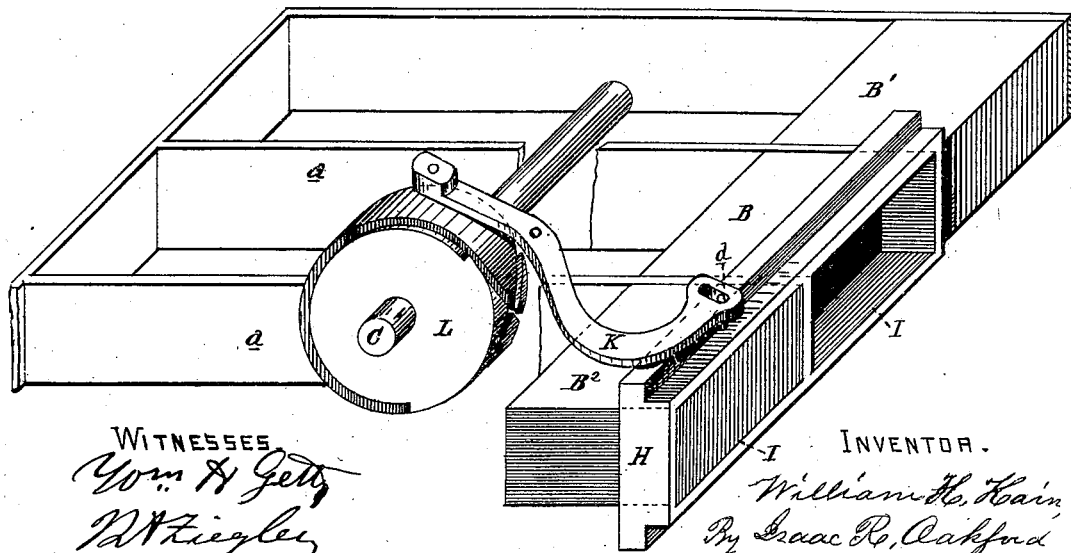

FIG III



WITNESSES  
*Yours H Getty*  
*W H Kieley*

INVENTOR.  
*William H. Kain*  
 By *Isaac R. Oakford*  
 His Attorney.

# UNITED STATES PATENT OFFICE.

WILLIAM H. KAIN, OF PHILADELPHIA, PENNSYLVANIA, ASSIGNOR OF ONE HALF HIS RIGHT TO JOHN Q. A. ZIEGLER, OF SAME PLACE.

## IMPROVEMENT IN BRICK-MACHINES.

Specification forming part of Letters Patent No. **199,072**, dated January 8, 1878; application filed February 9, 1877.

*To all whom it may concern:*

Be it known that I, WILLIAM H. KAIN, of the city and county of Philadelphia, and State of Pennsylvania, have invented a new and useful Improvement in Brick-Machines, which improvement is fully set forth in the following specification and accompanying drawing, in which—

Figure 1 is a longitudinal vertical section of my invention. Fig. 2 is a plan view of the same. Fig. 3 is an end view of the machine. Fig. 4 is a perspective view of the reciprocating molds and plungers used in the machine.

My invention consists in combining, in a brick-machine, a rectangular-shaped frame, provided with three parallel divisions, in which are located a compression and two discharging plungers, connected with and receiving motion from a triple crank-shaft; a transverse sliding mold-frame, with lever and grooved cam-wheel for operating the same; and an air-valve, which opens for the exit of air while the mold is filling, and closes when the clay is compressed.

The object of my invention is to provide a machine which will embody simplicity in construction, be economical in operation, and easily repaired or cleaned when occasions require.

The frame A of the machine, which is of a rectangular shape, is divided, by the longitudinal partitions *aa*, into three divisions, as shown at Figs. 2 and 4. B, B<sup>1</sup>, and B<sup>2</sup> are three plungers or pistons, located in said divisions at the front end of the machine, and supported upon guides bolted to or formed on the sides and partitions of the frame. These plungers are arranged parallel, and are reciprocated from a crank-shaft, C, mounted transversely in bearings D and D' at or near the center of the frame.

E, E<sup>1</sup>, and E<sup>2</sup> are cranks on the shaft C, and F, F<sup>1</sup>, and F<sup>2</sup> are forked rods or levers, for connecting the plungers to the same. G, Figs. 1 and 2, is a covering-plate, placed over the plungers and bolted to the frame, to shield the plungers and assist in maintaining them in position.

The frame H, which is operated in conjunction with the three plungers B, B<sup>1</sup>, and B<sup>2</sup>, is constructed to form two brick-molds, I I, and is arranged in guides J J, formed on or bolted to the front end of the machine, and receives

a transverse reciprocating movement from a lever, K, pivoted to the frame and operated from a grooved cam-wheel, L, on the shaft C, as shown in Figs. 2 and 4.

The clay is compressed and the bricks formed by the central plunger B, immediately in front of which and on the outside of the mold-frame H is a platen, M, bolted securely to the end of the machine to receive the pressure of the molded clay, as shown in Figs. 1, 2, and 3. N is an air-valve, arranged in the center of the said platen and opening into the brick-molds, for the exit of air while the clay is being forced into the mold. The said valve is connected to a lever, O, which has its fulcrum on the front end of the machine, and is provided with a spring for retaining the valve open. The upper end of the lever O is connected to a sliding rod, R, which is supported in a bearing on the top of the frame, and is forced outward to close the valve when the upright S, on the plunger B<sup>1</sup>, is brought in contact with it.

The right and left plungers B<sup>1</sup> and B<sup>2</sup>, which alternately discharge the molded bricks from the molds I I, are each made of greater length than the compression-plunger B, in order that the front end will be in advance and project through one of the molds and discharge a finished brick while the center plunger is compressing the clay in the other mold. The clay is received from the pug-mill T into an open space, U, in front of the plunger B. This space holds sufficient clay to form one brick at a time, the clay being cut off from the pug-mill by the advancing plunger.

The grooves in the cam-wheel L are arranged to cross in a right and left direction, so as to shift the rear end of the lever K from one side to the other, which movement carries the mold-frame H, which is connected to the front end of the lever by means of the vertical pin *d*, from side to side of the machine.

When the swivel at the rear end of the lever is traveling in the straight portion of the groove on the right or left hand side of the cam, the mold-frame is at rest and the plunger B is compressing the clay, while the side plunger B<sup>2</sup> (for example) is discharging a finished brick. When the center plunger has finished compressing the clay and a brick is discharged from one

mold, the frame is shifted by the cam and lever toward the opposite side of the machine until the filled mold is directly opposite the discharging-plunger B<sup>1</sup> and the empty mold opposite the plunger B, in which position the operation of compressing and discharging a brick is repeated.

The vertical shaft Q of the pug-mill is provided with blades *e e e*, &c., for mixing and tempering the clay, and with a screw, Y, at the lower end, for forcing the clay into the open space in front of the compression-plunger. The said shaft is driven by means of a bevel-gear wheel, P, on the upper end, and a similar wheel, P', on a horizontal shaft, V.

An endless chain, X, passing over a chain-pulley, Z, on the shaft C, and over a smaller pulley, Z', on the shaft V, communicates motion to the gearing and also to the vertical shaft.

The shaft C is driven from a shaft, C', through a pinion, W, and a spur-wheel, W'.

Having thus described my invention, what I claim as new, and desire to secure by Letters Patent, is—

1. In combination with the molds I I, compression-plunger B, and platen M, the air-valve N, lever O, rod R, and upright S, operated by the movement of the plungers B<sup>1</sup> and B<sup>2</sup>, substantially as herein shown and described.

2. The combination, in a brick-machine, of the frame A, partitions *a a*, compression-plunger B, discharging-plungers B<sup>1</sup> and B<sup>2</sup>, shaft C, cranks E, E<sup>1</sup>, and E<sup>2</sup>, levers F, F<sup>1</sup>, and F<sup>2</sup>, movable mold-frame H, guides J J, platen M, grooved cam-wheel L, lever K, shaft C', pinion W, and spur-wheel W', operating substantially as herein shown and described.

WILLIAM H. KAIN.

Witnesses:

ALEXANDER H. MORGAN,  
ISAAC R. OAKFORD.